

Spare parts for Trucks and Buses

MERCEDES-BENZ

SK-/MK-/NG-Series (OM 400 engine)



ERQO[®]
spare part products

www.erqo.com.tr

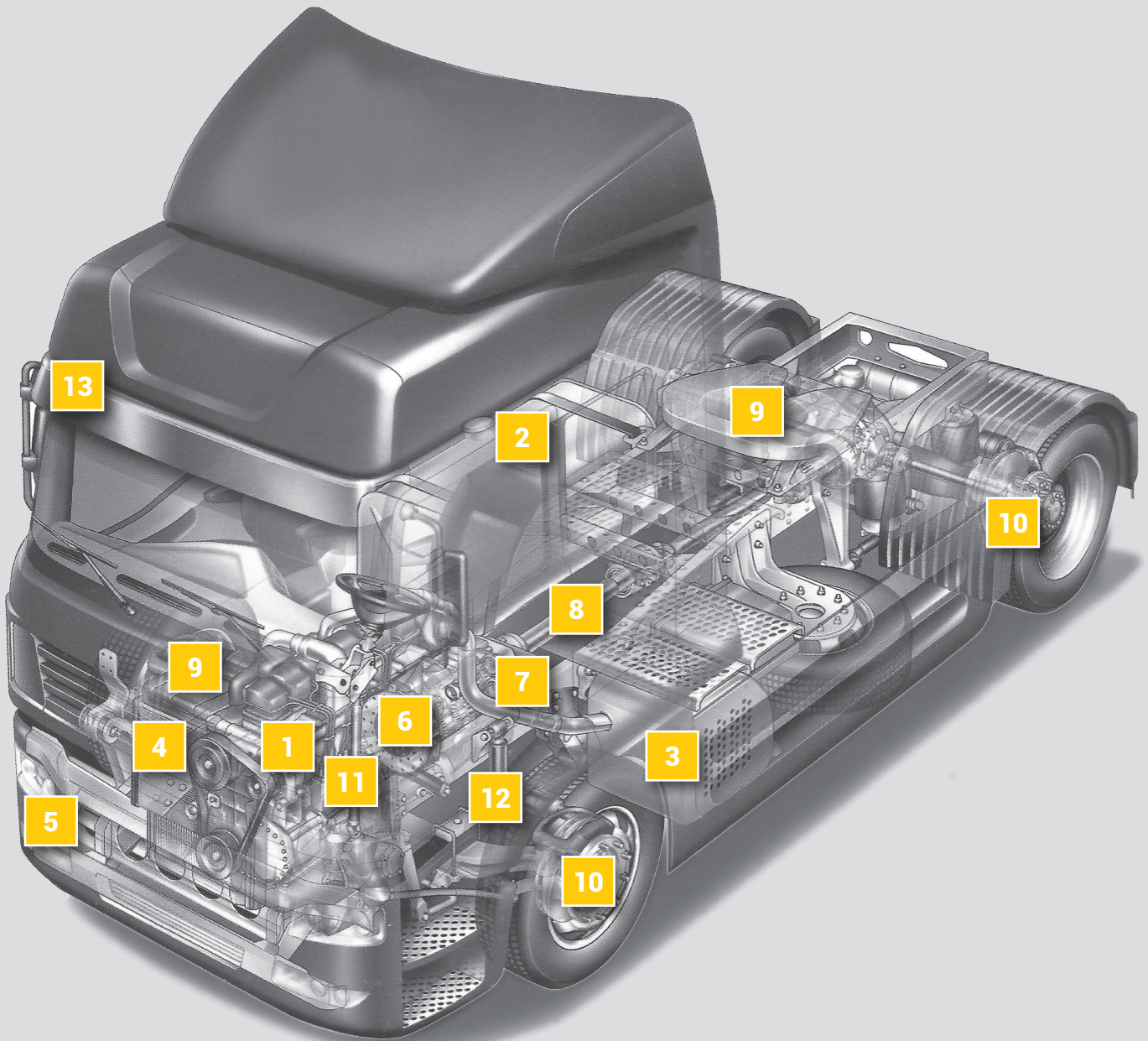

SPARE PARTS CATALOGUE

ERSATZTEIL - KATALOG

CATALOGUE DE PIECES DETACHEES

CATALOGO DE RECAMBIOS

CATALOGO DE PEÇAS DE REPOSIÇÃO

КАТАЛОГ ЗАПАСНЫХ ЧАСТЕЙ

ONDERDELEN CATALOGUS

ERQO[®]
spare part products

Mercedes

SK-/MK-/NG-Series
(OM 400 engine)

ERQO[®]
spare part products

www.erqo.com.tr

ERKU OTOMOTIV SAN. VE TİC. LTD. ŞTİ.

İkitelli Org. San. Bölge Dolapdere San. Sit.

19. Ada No:18 Başakşehir

İSTANBUL - TURKEY

Phone : +90 212 407 02 68

Fax : +90 212 407 02 87

E-mail : info@erqo.com.tr

Web : www.erqo.com.tr

THE ORIGINAL NUMBERS OF THE VEHICLE MANUFACTURER MAY BE USED FOR COMPARISON PURPOSES ONLY AND MUST NOT BE MENTIONED ON INVOICES TO VEHICLE OWNERS.



ERQO Auto Spare Parts located in Istanbul / TURKEY which was founded in Istanbul in 2010 to organize the export and import activities of ERTAS Automotive which is our head company that had been founded in 1959. Always giving of initial importance to customer's satisfaction since the day it was founded. ERQO Automotive offered ERQO-branded goods for sale in 2010 on account of the high demand from its customers on the experience it gained for fifty-two years. Today we export 85% of our ERQO-branded goods as a result of the most care we pay to quality.

As we ERQO, serving our customers;

We offer all spare parts of **Mercedes Benz, Man** from A to Z with best prices.

As a brand with the principle of raising the level in the growing world market and having a successful process, we continue our operation of handling the supply of spare parts for other commercial vehicle groups such as **Volvo, DAF, Scania, Renault, etc...** with up to 9000 references.

With its wide product range, strong logistic network and competitive pricing strategy, ERQO offers spare part solutions that make a difference in the commercial vehicle market and continues to work with the vision of being world brand.

Working with international and OE service providers in Turkey and All-around World, ERQO receives its full strength from the quality of its products, as well as its customer-focused approach in after sales services.

Having embraced the principle of sustainable growth, ERQO will continue to take steps to add worthiness to all its business partners.



www.erqo.com.tr/index.php?lang=tr

ERQO
Spare Parts

WhatsApp
+90 545 640 62 40

Home About Us Products Quality Gallery Contact

LARGE RANGE OF SPARE PARTS FOR COMMERCIAL VEHICLES

The Genuine Alternative
Genuine Durability with ERQO reliability.

New Parts Supplier
Our key focus is being the best in quality and service for you.

Access to B2B
Click here to explore our stock and purchase.

ERQO AUTOMOTIVE

We are offering Replacement Parts for Scania | Volvo | Daf | Renault | Iveco | Mercedes | Man Trucks and Buses.

We at ERQO Spare Parts are committed to providing the Best Quality Parts at the Best Possible Prices and Delivering them to you on time, we have been supplying parts for both Turkey and Export markets with over 38 years experience.

ERQO offers customers a One-Stop-Shop concept. Our range currently consists of over 10,000 items, shipped directly from stock. Through close cooperation with our suppliers we also have quick access to more than 1,000,000 items.



THE ORIGINAL NUMBERS OF THE VEHICLE MANUFACTURER MAY BE USED FOR COMPARISON PURPOSES ONLY AND MUST NOT BE MENTIONED ON INVOICES TO VEHICLE OWNERS.

CATEGORY	Group	Page
ENGINE HOUSING	01	
Crankcase & Gasket Kit	01 A	25
Crankcase Components	01 B	28
Timing Case	01 C	36
Oil Sump	01 D	40
Cylinder Head	01 E	47
MOVING PARTS	03	
Crankshaft	03 A	65
Flywheel	03 B	81
Connecting Rod	03 C	85
Piston & Liner	03 D	88
TIMING	05	
Camshaft	05 A	102
FUEL INJECTION	07	
Injection Pump	07 A	107
Injection Lines	07 B	115
Mechanical Control	07 C	132
FUEL FILTER & TURBOCHARGER	09	
Fuel Filter	09 A	135
Turbocharger	09 B	139
COMPRESSOR	13	
Compressor Components	13 A	145
Hoses	13 B	164
MANIFOLD	14	
Intake Manifold	14 A	167
Exhaust Manifold	14 B	169
ENGINE ELECTRONICS	15	
Starter	15 A	177
Alternator	15 B	179
Switches & Sensors	15 C	184
ENGINE LUBRICATION	18	
Oil Pump	18 A	185
Oil Cooler & Oil Filter	18 B	188
Oil Line	18 C	195
ENGINE COOLING	20	
Water Pump & Thermostat	20 A	198
Fan	20 B	207
V-Belts	20 C	214
Coolant Line	20 D	217
EXTRA FITTINGS	23	
Steering Pump	23 A	220
Power-Take-Off	23 B	224
ENGINE SUSPENSION	24	
Rubber Mounting	24 A	225
CLUTCH	25	
Clutch Cover & Clutch Disc	25 A	231
Release Lever	25 B	245
Clutch Servo & Cylinder	25 C	249
GEARBOX	26	
Gear Shift Lever	26 A	257
Gaskets & Seal Rings	26 B	264
Gearbox Housing	26 C	270
Bearings	26 D	275
Gears	26 E	283
Shifting Fork	26 F	301
Shifting Cylinder	26 G	304
Shifting Shaft	26 H	310
Switches & Valves	26 I	324
TRANSFER CASE	28	
Suspension	28 A	329
PEDAL SYSTEM	29	
Clutch & Brake Pedal	29 A	330
Cylinder & Valves	29 B	334
Hoses	29 C	336
CONTROL	30	
Accelerator Pedal	30 A	340
FRAME	31	
Spring Bracket	31 A	349
Cabin Mounting	31 B	359
SUSPENSION	32	
Suspension, Front Axle	32 A	366
Stabilizer, Front Axle	32 B	370
Shock Absorber, Front Axle	32 C	378
Suspension, Rear Axle	32 D	381
Stabilizer, Rear Axle	32 E	387
Shock Absorber, Rear Axle	32 F	394
Air Spring	32 G	397
Spring Saddle	32 H	399
Level Valve	32 I	404
Reaction Rod & V-Stay	32 J	406

CATEGORY	Group	Page
FRONT AXLE	33	
Steering Knuckle	33 A	411
Track Rod	33 B	415
Axle Shaft	33 C	417
Wheel Hub	33 D	418
REAR AXLE	35	
Housing	35 A	425
Differential	35 B	426
Wheel Hub	35 C	431
WHEELS	40	
Wheel Bolts	40 A	440
PROPELLER SHAFT	41	
Components	41 A	452
BRAKE SYSTEM	42	
Brake Drum	42 A	456
Slack Adjuster	42 B	467
Brake Camshaft	42 C	472
Brake Cylinder	42 D	475
Air Dryer & Governor	42 E	479
Protection Valve	42 F	483
Foot & Hand Brake Valve	42 G	487
Trailer Brake Valve	42 H	494
Other Valves	42 I	497
Brake Line & Connector	42 J	500
Palm Couplings & Electrical Spiral	42 K	526
EXHAUST BRAKE	43	
Valves	43 A	542
STEERING	46	
Steering Column	46 A	545
Oil Filter	46 B	548
Drag Link	46 C	551
Power Steering Gear	46 D	556
FUEL SYSTEM	47	
Fuel Tank	47 A	557
EXHAUST SYSTEM	49	
Silencer & Pipes	49 A	562
Gaskets & Rubber Bearing	49 B	572
COOLING SYSTEM	50	
Radiator & Expansion Tank	50 A	574
Radiator Hoses	50 B	583
Intercooler	50 C	605
AIR INLET	52	
Air Filter	52 A	607
ELECTRICAL EQUIPMENT	54	
Switch & Battery	54 A	615
Relay	54 B	620
Instrument Panel	54 C	622
CABIN HYDRAULIC	55	
Tilt Pump & Cylinder	55 A	627
Hydraulic Hose	55 B	632
TOOLING & ACCESSORIES	58	
Tooling	58 A	635
Accessory	58 B	636
STEP	66	
Step	66 A	638
WINDOW	67	
Windscreen & Window	67 A	639
DOOR	72	
Door	72 A	640
OUTER FLAPS, CABIN	75	
Front Grill	75 A	648
OUTER EQUIPMENT, CABIN	81	
Mirror	81 A	653
Sun Visor	81 B	659
ELECTRICAL SYSTEM	82	
Lighting, front	82 A	660
Lighting, side & rear	82 B	664
Bulbs	82 C	667
Wiper System	82 D	671
HEATING & VENTILATION	83	
Heating & Air Conditioning	83 A	673
ATTACHMENT PARTS, CABIN	88	
Bumper	88 A	676
Mudguard	88 B	678
SEMI-TRAILER	99	
Springs	99 A	679

THE ORIGINAL NUMBERS OF THE VEHICLE MANUFACTURER MAY BE USED FOR COMPARISON PURPOSES ONLY AND MUST NOT BE MENTIONED ON INVOICES TO VEHICLE OWNERS.

Application	Page	Erqo No.	Application	Page	Erqo No.	Application	Page	Erqo No.
443 035 0113	76	02.19673	403 053 0052	56	02.19756	000 072 3212	130	02.19839
403 035 0614	78	02.19674	403 053 0152	56	02.19757	402 072 0124	130	02.19840
403 035 0914	78	02.19675	403 053 0196	54	02.19758	403 072 0324	131	02.19841
422 035 1114	78	02.19676	422 053 0196	54	02.19759	422 072 0424	131	02.19842
442 035 0214	78	02.19677	403 054 1801	103	02.19760	423 072 0324	131	02.19843
422 035 0071	76	02.19678	403 054 0405	104	02.19761	403 074 0059	111	02.19844
403 038 2410	71	02.19679	422 054 0105	104	02.19762	442 074 0059	112	02.19845
403 038 0250	84	02.19680	442 055 0020	60	02.19763	000 074 5171	135	02.19846
403 038 0450	84	02.19681	403 055 0650	59	02.19764	442 074 0071	136	02.19847
442 038 0050	83	02.19682	403 070 8321	132	02.19765	001 074 2280	108	02.19848
442 038 0150	84	02.19683	441 070 0621	132	02.19766	000 074 0684	111	02.19849
403 038 0271	84	02.19684	442 070 1321	132	02.19767	000 074 3884	111	02.19850
442 038 0071	85	02.19685	442 070 3021	132	02.19768	000 074 7684	111	02.19851
401 050 1701	100	02.19686	403 070 2533	121	02.19769	403 077 0512	112	02.19852
401 050 1801	100	02.19687	403 070 2633	121	02.19770	403 077 0712	112	02.19853
401 050 2201	100	02.19688	403 070 2733	121	02.19771	403 078 0074	129	02.19854
402 050 1601	100	02.19689	403 070 2833	120	02.19772	422 090 0007	135	02.19855
402 050 1801	100	02.19690	403 070 4933	122	02.19773	000 090 0210	107	02.19856
402 050 2501	101	02.19691	403 070 5133	122	02.19774	000 090 0610	108	02.19857
403 050 2901	101	02.19692	403 070 6033	122	02.19775	442 090 1641	135	02.19858
403 050 3201	101	02.19693	403 070 7433	122	02.19776	000 090 0550	105	02.19859
403 050 3701	101	02.19694	421 070 3033	124	02.19777	000 090 0650	105	02.19860
403 050 4001	101	02.19695	421 070 3133	124	02.19778	000 090 2150	105	02.19861
421 050 1401	101	02.19696	421 070 3233	124	02.19779	000 090 3050	105	02.19862
422 050 0301	102	02.19697	422 070 0933	117	02.19780	000 090 3150	105	02.19863
422 050 0401	102	02.19698	422 070 1033	117	02.19781	000 090 6050	109	02.19864
422 050 0501	102	02.19699	422 070 4933	127	02.19782	000 090 7350	110	02.19865
422 050 1001	102	02.19700	422 070 5033	126	02.19783	000 090 8850	110	02.19866
422 050 2101	102	02.19701	422 070 5133	126	02.19784	000 090 0151	108	02.19867
422 050 2201	102	02.19702	422 070 5233	126	02.19785	000 090 0751	110	02.19868
423 050 1401	103	02.19703	422 070 5433	118	02.19786	000 090 1151	134	02.19869
441 050 0001	103	02.19704	422 070 6333	124	02.19787	000 090 1351	110	02.19870
441 050 0201	102	02.19705	422 070 6433	123	02.19788	000 090 1451	134	02.19871
441 050 0601	102	02.19706	422 070 6533	123	02.19789	422 090 0051	134	02.19872
441 050 1601	103	02.19707	422 070 6633	123	02.19790	442 090 0352	133	02.19873
441 050 1701	100	02.19708	422 070 6733	124	02.19791	000 091 1101	106	02.19874
442 050 1701	101	02.19709	422 070 7533	123	02.19792	000 091 0039	109	02.19875
403 050 0303	75	02.19710	422 070 7633	123	02.19793	000 091 0040	109	02.19876
403 050 0403	74	02.19711	422 070 7733	123	02.19794	000 091 0840	107	02.19877
403 050 0325	104	02.19712	422 070 7833	122	02.19795	000 091 0541	108	02.19878
422 050 0025	104	02.19713	423 070 0333	127	02.19796	000 091 1341	108	02.19879
422 050 0325	104	02.19714	423 070 0433	127	02.19797	000 091 2190	106	02.19880
476 050 0025	104	02.19715	423 070 0533	127	02.19798	001 092 1801	133	02.19881
422 050 0226	54	02.19716	423 070 0633	128	02.19799	000 092 3303	111	02.19882
423 050 0026	54	02.19717	423 070 0733	125	02.19800	422 092 0108	134	02.19883
442 050 0226	54	02.19718	423 070 0833	126	02.19801	000 094 0004	546	02.19884
442 050 0526	54	02.19719	423 070 0933	126	02.19802	001 094 8304	605	02.19885
422 050 0127	54	02.19720	423 070 1033	126	02.19803	001 094 9304	605	02.19886
423 050 0427	54	02.19721	423 070 2133	126	02.19804	002 094 2404	605	02.19887
442 050 0227	54	02.19722	423 070 2233	125	02.19805	003 094 1504	606	02.19888
403 050 0733	59	02.19723	423 070 2333	126	02.19806	003 094 1604	606	02.19889
442 050 0333	59	02.19724	423 070 2333	126	02.19807	003 094 4204	607	02.19890
403 050 1236	59	02.19725	423 070 2833	122	02.19808	003 094 7004	606	02.19891
403 050 1436	59	02.19726	441 070 1133	115	02.19809	000 094 7980	607	02.19892
403 053 0120	55	02.19727	441 070 2533	125	02.19810	000 094 8080	607	02.19893
403 053 0720	55	02.19728	441 070 2733	125	02.19811	001 094 8980	607	02.19894
403 053 1020	55	02.19729	441 070 5333	115	02.19812	001 094 1182	610	02.19895
403 053 1120	55	02.19730	441 070 5433	115	02.19813	001 094 2682	608	02.19896
403 053 0622	55	02.19731	441 070 5533	114	02.19814	002 094 5282	604	02.19897
403 053 1022	55	02.19732	441 070 6433	115	02.19815	002 094 5482	604	02.19898
403 053 1122	55	02.19733	441 070 6733	115	02.19816	002 094 6382	604	02.19899
403 053 0325	56	02.19734	442 070 1333	119	02.19817	002 096 2299	137	02.19900
422 053 0025	56	02.19735	442 070 1433	119	02.19818	002 096 6599	137	02.19901
000 053 0426	56	02.19736	442 070 6133	125	02.19819	003 096 0899	137	02.19902
102 053 0026	58	02.19737	442 070 8133	119	02.19820	003 096 2599	137	02.19903
422 053 0026	57	02.19738	442 070 8333	116	02.19821	003 096 2799	137	02.19904
403 053 0030	54	02.19739	442 070 8333	118	02.19822	003 096 5599	137	02.19905
422 053 0430	54	02.19740	442 070 8433	116	02.19823	004 096 0899	137	02.19906
402 053 0131	53	02.19741	442 070 9633	119	02.19824	004 096 0999	137	02.19907
403 053 0331	52	02.19742	403 070 0434	113	02.19825	004 096 3699	137	02.19908
403 053 0931	52	02.19743	403 070 0934	121	02.19826	004 096 6099	137	02.19909
403 053 1031	52	02.19744	403 070 1034	120	02.19827	005 096 2599	138	02.19910
403 053 1131	52	02.19745	403 070 0055	129	02.19828	005 096 9399	138	02.19911
422 053 0531	52	02.19746	326 070 0063	520	02.19829	421 098 0116	141	02.19912
422 053 0631	52	02.19747	355 070 0475	338	02.19830	422 098 0016	142	02.19913
422 053 0731	52	02.19748	000 070 1583	130	02.19831	442 098 0980	165	02.19914
442 053 0531	53	02.19749	000 070 1983	130	02.19832	442 098 1080	165	02.19915
403 053 0232	52	02.19750	000 070 2183	130	02.19833	897 120 5204	474	02.19916
403 053 2132	53	02.19751	000 072 0112	130	02.19834	442 130 0002	149	02.19917
403 053 2332	52	02.19752	000 072 1512	130	02.19835	402 130 0308	149	02.19918
442 053 0032	53	02.19753	000 072 1812	130	02.19836	402 130 0608	149	02.19919
442 053 0132	52	02.19754	000 072 1912	130	02.19837	403 130 0008	149	02.19920
442 053 0232	52	02.19755	000 072 2512	130	02.19838	427 130 0008	149	02.19921

THE ORIGINAL NUMBERS OF THE VEHICLE MANUFACTURER MAY BE USED FOR COMPARISON PURPOSES ONLY AND MUST NOT BE MENTIONED ON INVOICES TO VEHICLE OWNERS.

Application	Page	Erqo No.	Application	Page	Erqo No.	Application	Page	Erqo No.
422 200 0901	200	02.20171	300 240 0117	223	02.20254	013 250 2603	235	02.20337
422 200 1001	197	02.20172	301 240 3517	223	02.20255	013 250 3003	235	02.20338
422 200 1101	198	02.20173	383 240 1017	223	02.20256	013 250 3903	235	02.20339
422 200 1301	197	02.20174	387 240 0317	223	02.20257	013 250 4103	235	02.20340
422 200 1401	197	02.20175	615 240 0317	225	02.20258	013 250 7403	237	02.20341
441 200 0101	198	02.20176	617 240 0017	223	02.20259	013 250 7903	237	02.20342
441 200 0201	198	02.20177	617 240 0217	224	02.20260	013 250 8703	237	02.20343
441 200 0301	198	02.20178	620 240 0317	223	02.20261	013 250 8803	237	02.20344
422 200 0104	199	02.20179	620 240 0417	223	02.20262	014 250 6803	235	02.20345
422 200 0204	199	02.20180	620 240 0517	223	02.20263	014 250 7603	237	02.20346
422 200 0304	199	02.20181	620 240 0717	223	02.20264	014 250 7703	237	02.20347
422 200 0404	199	02.20182	357 240 0118	225	02.20265	014 250 7803	237	02.20348
422 200 0504	199	02.20183	383 240 0718	225	02.20266	015 250 0203	235	02.20349
422 200 0604	199	02.20184	387 240 0218	225	02.20267	015 250 2203	235	02.20350
423 200 0004	199	02.20185	387 240 0418	225	02.20268	015 250 2303	235	02.20351
423 200 0104	199	02.20186	616 240 0618	227	02.20269	015 250 2403	237	02.20352
441 200 0104	199	02.20187	617 240 0018	225	02.20270	015 250 3203	235	02.20353
441 200 0204	199	02.20188	617 240 0318	225	02.20271	016 250 0903	235	02.20354
000 200 4622	211	02.20189	617 240 0418	225	02.20272	016 250 1003	235	02.20355
000 200 4722	210	02.20190	617 240 0518	225	02.20273	016 250 1703	235	02.20356
000 200 7022	210	02.20191	620 240 0318	225	02.20274	016 250 1803	235	02.20357
000 200 7122	210	02.20192	620 240 0418	225	02.20275	016 250 1903	237	02.20358
000 200 8122	210	02.20193	620 240 0518	225	02.20276	016 250 2703	235	02.20359
444 200 0123	209	02.20194	645 240 0018	225	02.20277	016 250 2803	235	02.20360
403 200 0926	210	02.20195	645 240 0118	225	02.20278	016 250 4003	237	02.20361
403 200 0452	216	02.20196	645 240 0218	225	02.20279	016 250 4103	237	02.20362
403 200 1652	215	02.20197	645 240 0318	226	02.20280	016 250 4203	237	02.20363
403 200 1852	217	02.20198	645 240 0418	226	02.20281	016 250 4303	237	02.20364
403 200 2152	216	02.20199	645 240 0518	225	02.20282	016 250 4403	235	02.20365
403 200 2752	217	02.20200	645 240 0618	226	02.20283	016 250 5003	237	02.20366
422 200 0752	215	02.20201	645 240 0718	226	02.20284	018 250 3703	233	02.20367
422 200 1552	217	02.20202	645 240 0918	226	02.20285	018 250 7803	235	02.20368
422 200 2952	215	02.20203	652 240 0318	226	02.20286	018 250 9303	235	02.20369
442 200 2452	216	02.20204	652 241 0213	224	02.20287	018 250 9603	237	02.20370
442 200 3152	215	02.20205	653 241 0213	224	02.20288	019 250 0803	235	02.20371
442 200 8152	215	02.20206	655 241 0613	225	02.20289	019 250 3203	237	02.20372
442 200 8252	216	02.20207	655 241 0713	224	02.20290	019 250 6803	235	02.20373
442 200 0553	215	02.20208	658 241 0013	223	02.20291	020 250 5903	237	02.20374
442 200 0770	211	02.20209	658 241 0113	223	02.20292	000 250 0004	230	02.20375
403 200 0495	209	02.20210	658 241 0213	223	02.20293	002 250 3104	230	02.20376
442 200 0195	209	02.20211	020 250 4701	229	02.20294	002 250 3204	231	02.20377
442 200 0595	210	02.20212	020 250 4901	229	02.20295	002 250 3904	230	02.20378
442 200 1195	210	02.20213	020 250 5001	229	02.20296	002 250 4004	230	02.20379
000 201 3619	201	02.20214	020 250 5101	230	02.20297	002 250 4104	231	02.20380
000 201 8719	201	02.20215	020 250 5201	230	02.20298	002 250 7504	231	02.20381
000 201 9819	201	02.20216	002 250 3303	238	02.20299	002 250 9904	231	02.20382
000 201 9919	201	02.20217	005 250 0103	234	02.20300	003 250 0004	231	02.20383
001 201 1719	201	02.20218	005 250 4003	233	02.20301	003 250 2504	230	02.20384
442 201 0531	202	02.20219	005 250 6003	234	02.20302	003 250 2604	231	02.20385
000 201 0463	201	02.20220	005 250 6103	234	02.20303	003 250 2704	230	02.20386
403 201 0380	200	02.20221	007 250 1003	234	02.20304	003 250 2804	230	02.20387
442 201 0080	200	02.20222	007 250 4203	234	02.20305	003 250 3304	231	02.20388
442 201 1080	200	02.20223	007 250 4303	234	02.20306	003 250 4104	231	02.20389
000 201 0197	201	02.20224	007 250 4703	236	02.20307	003 250 6104	232	02.20390
403 202 0610	202	02.20225	007 250 4903	236	02.20308	003 250 7004	231	02.20391
403 202 0710	202	02.20226	007 250 5003	236	02.20309	003 250 8604	232	02.20392
403 202 1310	201	02.20227	007 250 5903	235	02.20310	003 250 9004	232	02.20393
403 202 1710	202	02.20228	007 250 7403	233	02.20311	004 250 2404	231	02.20394
442 202 0210	202	02.20229	008 250 1603	236	02.20312	004 250 4104	233	02.20395
403 202 0414	201	02.20230	008 250 1703	236	02.20313	004 250 4404	233	02.20396
542 202 0114	201	02.20231	008 250 5103	235	02.20314	004 250 4504	233	02.20397
003 203 7375	204	02.20232	008 250 7403	234	02.20315	004 250 4604	232	02.20398
003 203 7475	203	02.20233	008 250 9703	235	02.20316	004 250 5504	233	02.20399
003 203 7975	203	02.20234	009 250 0103	234	02.20317	004 250 6004	232	02.20400
004 203 8375	204	02.20235	009 250 2103	235	02.20318	004 250 6104	232	02.20401
004 203 8475	203	02.20236	009 250 3103	235	02.20319	004 250 8704	232	02.20402
005 203 2675	204	02.20237	010 250 0203	238	02.20320	004 250 8904	233	02.20403
001 205 6106	208	02.20238	010 250 5703	237	02.20321	005 250 6204	233	02.20404
001 205 6206	208	02.20239	010 250 5803	237	02.20322	005 250 7604	233	02.20405
001 205 9206	205	02.20240	010 250 7703	236	02.20323	005 250 7704	233	02.20406
002 205 1506	205	02.20241	010 250 7803	236	02.20324	005 250 8304	232	02.20407
002 205 3506	205	02.20242	010 250 8903	237	02.20325	005 250 8404	232	02.20408
002 205 6206	207	02.20243	010 250 9203	237	02.20326	005 250 8704	233	02.20409
002 205 7006	207	02.20244	011 250 0403	235	02.20327	005 250 8804	233	02.20410
002 205 7806	205	02.20245	011 250 0603	235	02.20328	650 250 3813	243	02.20411
002 205 8306	205	02.20246	011 250 1303	236	02.20329	385 250 0014	243	02.20412
002 205 9306	208	02.20247	011 250 1403	236	02.20330	389 250 0014	243	02.20413
002 205 9706	206	02.20248	011 250 1703	236	02.20331	620 250 0214	243	02.20414
003 205 0006	206	02.20249	011 250 1803	236	02.20332	000 250 1915	238	02.20415
003 205 1606	206	02.20250	012 250 1403	235	02.20333	000 250 2515	238	02.20416
423 205 0540	211	02.20251	012 250 1503	235	02.20334	000 250 4215	238	02.20417
423 205 0740	211	02.20252	013 250 2003	235	02.20335	000 250 4615	238	02.20418
442 205 3940	211	02.20253	013 250 2103	235	02.20336	000 250 7315	239	02.20419

THE ORIGINAL NUMBERS OF THE VEHICLE MANUFACTURER MAY BE USED FOR COMPARISON PURPOSES ONLY AND MUST NOT BE MENTIONED ON INVOICES TO VEHICLE OWNERS.

Application	Page	Erqo No.	Application	Page	Erqo No.	Application	Page	Erqo No.
673 725 0001	640	02.22162	001 824 3001	669	02.22245	008 981 6901	277	02.22328
381 725 0002	639	02.22163	381 824 0228	669	02.22246	001 981 2905	417	02.22329
381 725 0102	639	02.22164	002 826 0190	660	02.22247	001 981 7605	417	02.22330
381 725 0139	644	02.22165	002 826 0290	660	02.22248	002 981 5305	399	02.22331
381 725 0043	640	02.22166	002 826 0690	659	02.22249	002 981 7905	416	02.22332
381 725 0060	640	02.22167	002 826 0790	659	02.22250	003 981 2605	433	02.22333
381 725 0466	643	02.22168	002 826 0890	660	02.22251	003 981 6805	399	02.22334
381 725 0566	643	02.22169	002 826 0990	660	02.22252	003 981 7405	417	02.22335
381 725 0279	643	02.22170	002 826 1290	659	02.22253	004 981 0905	433	02.22336
381 725 0379	643	02.22171	002 826 1390	659	02.22254	004 981 1805	399	02.22337
641 750 1009	646	02.22172	000 830 8608	671	02.22255	004 981 4305	399	02.22338
649 750 0118	646	02.22173	001 830 0308	671	02.22256	005 981 3105	417	02.22339
641 750 0059	648	02.22174	381 830 0131	647	02.22257	005 981 4905	433	02.22340
649 750 0159	648	02.22175	381 830 0231	647	02.22258	006 981 0805	417	02.22341
000 750 0184	646	02.22176	389 830 0031	647	02.22259	006 981 6305	417	02.22342
000 750 0484	646	02.22177	000 830 1384	672	02.22260	006 981 9905	417	02.22343
641 750 0093	646	02.22178	000 830 3584	672	02.22261	007 981 7005	417	02.22344
641 752 0096	647	02.22179	381 832 1823	673	02.22262	008 981 2805	279	02.22345
673 760 0002	640	02.22180	002 835 0801	672	02.22263	009 981 4305	433	02.22346
641 760 0004	642	02.22181	002 835 2701	672	02.22264	011 981 1305	279	02.22347
381 760 0059	641	02.22182	002 835 6801	672	02.22265	012 981 9205	279	02.22348
641 760 0259	642	02.22183	000 835 6947	673	02.22266	012 981 9305	280	02.22349
641 760 0359	642	02.22184	000 860 1226	670	02.22267	014 981 1405	280	02.22350
670 760 0159	642	02.22185	000 860 3226	670	02.22268	014 981 1505	280	02.22351
381 766 0901	642	02.22186	000 860 0647	670	02.22269	014 981 1605	279	02.22352
381 766 0043	641	02.22187	000 860 1047	670	02.22270	014 981 6105	280	02.22353
641 810 0012	654	02.22188	000 869 3121	670	02.22271	015 981 1605	279	02.22354
641 810 0112	653	02.22189	000 869 3347	675	02.22272	015 981 2005	280	02.22355
381 810 0814	653	02.22190	649 880 0136	649	02.22273	015 981 7605	280	02.22356
641 810 1114	653	02.22191	649 880 0736	675	02.22274	015 981 9005	280	02.22357
641 810 1214	653	02.22192	641 880 0270	674	02.22275	001 981 7410	274	02.22358
641 810 1314	654	02.22193	641 880 3770	674	02.22276	002 981 1610	273	02.22359
641 810 1414	654	02.22194	641 880 6270	674	02.22277	002 981 1710	274	02.22360
000 810 1516	652	02.22195	641 880 6370	674	02.22278	004 981 6310	415	02.22361
641 810 0016	651	02.22196	641 880 9970	674	02.22279	005 981 0510	273	02.22362
641 810 0116	651	02.22197	641 880 0473	674	02.22280	005 981 3110	320	02.22363
641 810 4216	651	02.22198	641.881.6901	676	02.22281	005 981 4410	330	02.22364
641 810 4416	652	02.22199	641 881 7001	676	02.22282	006 981 9010	176	02.22365
641 810 4616	655	02.22200	649 885 0001	674	02.22283	007 981 2110	320	02.22366
641 810 6316	656	02.22201	655 890 2903	359	02.22284	007 981 5510	276	02.22367
673 810 3816	655	02.22202	387 890 1319	357	02.22285	007 981 8810	273	02.22368
641 811 0226	654	02.22203	387 890 1619	357	02.22286	008 981 8310	275	02.22369
641 811 0326	654	02.22204	620 890 0019	358	02.22287	008 981 8610	276	02.22370
314 811 0330	652	02.22205	620 890 0119	358	02.22288	008 981 9410	274	02.22371
000 811 1333	653	02.22206	620 890 0219	358	02.22289	009 981 0410	244	02.22372
000 811 7033	651	02.22207	620 890 0319	358	02.22290	009 981 0510	320	02.22373
000 811 7133	655	02.22208	000 891 1405	357	02.22291	009 981 1510	275	02.22374
000 811 8433	652	02.22209	000 891 1605	357	02.22292	009 981 1610	274	02.22375
000 811 8533	655	02.22210	000 891 1805	357	02.22293	009 981 9010	276	02.22376
000 811 8633	656	02.22211	000 891 2005	357	02.22294	010 981 1010	273	02.22377
001 811 8033	655	02.22212	000 891 2205	357	02.22295	010 981 5310	275	02.22378
001 811 8533	651	02.22213	363 891 0717	362	02.22296	010 981 8010	258	02.22379
001 811 8633	652	02.22214	387 891 0717	360	02.22297	011 981 1210	276	02.22380
001 820 1501	669	02.22215	620 891 0017	360	02.22298	011 981 3410	331	02.22381
001 820 2221	660	02.22216	620 891 0417	629	02.22299	012 981 0610	274	02.22382
000 820 6242	671	02.22217	363 891 0223	362	02.22300	012 981 5910	273	02.22383
000 820 9742	671	02.22218	387 891 0323	362	02.22301	012 981 8910	275	02.22384
003 820 5042	669	02.22219	620 891 0051	358	02.22302	012 981 9210	275	02.22385
004 820 6742	669	02.22220	620 891 0151	358	02.22303	013 981 4910	320	02.22386
000 820 8045	669	02.22221	387 891 0957	360	02.22304	013 981 9110	273	02.22387
001 820 1145	669	02.22222	621 891 0057	360	02.22305	013 981 9210	274	02.22388
001 820 1245	669	02.22223	334 891 0072	362	02.22306	016 981 0010	275	02.22389
001 820 4745	669	02.22224	387 891 0072	361	02.22307	017 981 0210	275	02.22390
001 820 4845	669	02.22225	620 891 0072	361	02.22308	018 981 6610	275	02.22391
002 820 0056	660	02.22226	620 891 0172	361	02.22309	019 981 0910	275	02.22392
002 820 0456	660	02.22227	620 891 0272	361	02.22310	019 981 4410	275	02.22393
002 820 0556	661	02.22228	620 891 0372	361	02.22311	001 981 9912	276	02.22394
002 820 0656	661	02.22229	620 891 0472	361	02.22312	004 981 2125	81	02.22395
381 820 1061	658	02.22230	620 891 0073	363	02.22313	004 981 9325	278	02.22396
381 820 1161	658	02.22231	381 893 0603	642	02.22314	007 981 6625	178	02.22397
381 820 1261	658	02.22232	000 980 9702	433	02.22315	008 981 1225	178	02.22398
381 820 1361	658	02.22233	001 980 0902	417	02.22316	008 981 1325	278	02.22399
381 820 2961	659	02.22234	001 980 8002	278	02.22317	001 981 3931	258	02.22400
381 820 3061	659	02.22235	001 980 8102	277	02.22318	000 987 2627	499	02.22401
381 820 4361	659	02.22236	000 980 9064	648	02.22319	000 987 2727	500	02.22402
381 820 4461	659	02.22237	004 981 5801	276	02.22320	000 987 2827	501	02.22403
641 820 0361	658	02.22238	004 981 7601	277	02.22321	001 987 1140	366	02.22404
641 820 0461	658	02.22239	004 981 8001	277	02.22322	001 987 3140	571	02.22405
002 821 0651	624	02.22240	005 981 3801	277	02.22323	001 987 5340	571	02.22406
000 821 0552	661	02.22241	005 981 8501	278	02.22324	001 987 6340	612	02.22407
000 821 9960	671	02.22242	005 981 8901	277	02.22325	001 987 7140	327	02.22408
001 821 2760	672	02.22243	007 981 3001	35	02.22326	001 987 4257	644	02.22409
001 821 7860	672	02.22244	007 981 3001	155	02.22327	404 988 5235	184	02.22410

THE ORIGINAL NUMBERS OF THE VEHICLE MANUFACTURER MAY BE USED FOR COMPARISON PURPOSES ONLY AND MUST NOT BE MENTIONED ON INVOICES TO VEHICLE OWNERS.

Application	Page	Erqo No.
000 401 2471 S3	438	02.23200
000 401 2471 S4	438	02.23201
381 401 0571 S1	439	02.23202
381 401 0571 S2	439	02.23203
381 401 0571 S3	439	02.23204
381 401 0671 S1	439	02.23205
381 401 0671 S2	440	02.23206
381 401 0671 S3	440	02.23207
000 401 3771 S1	440	02.23208
000 401 3771 S2	440	02.23209
000 401 3771 S3	441	02.23210
000 401 3771 S4	441	02.23211
395 401 0070 S	445	02.23212
315 402 0070 S	445	02.23213
315 402 0170 S	445	02.23214
387 402 0470 S	445	02.23215
074361 020205	447	02.23216
699 420 0724	473	02.23217
000 144 0028	474	02.23218
000 431 1728	474	02.23219
000 421 2986	474	02.23220
897 120 5204	474	02.23221
000 423 1286	475	02.23222
897 120 550 4	475	02.23223
000 431 2028	475	02.23224
000 421 4286	475	02.23225
000 431 1928	476	02.23226
000 421 6286	476	02.23227
971 002 001 2	492	02.23230
971 002 150 0	492	02.23231
971 002 110 0	492	02.23232
971 002 152 0	492	02.23233
971 002 003 2	492	02.23234
971 002 004 2	493	02.23235
452 002 107 0	495	02.23236
475 604 011 0	495	02.23237
000 466 0267	547	02.23238
000 462 1896	553	02.23239
363 995 0065	576	02.23248
617 501 0282	576	02.23249
641 881 6901	676	02.23257
03.397.34.10.0	677	02.23258
05.397.26.03.0	677	02.23259
05.397.46.03.0	677	02.23260
05.397.45.05.0	678	02.23261
05.397.26.02.0	678	02.23262
03.397.34.01.0	678	02.23263
03.397.34.02.0	678	02.23264
1.447.0038.00	679	02.23265
1.447.0021.01	679	02.23266
210 23389	679	02.23267
03.296.23.17.0	449	02.23379
03.296.13.09.0	449	02.23380
03.260.04.06.0	449	02.23381
03.260.04.01.0	449	02.23382
	113	02.23104
	114	02.23105
	114	02.23106
	114	02.23107
	115	02.23108
	116	02.23109
	116	02.23110
	117	02.23111
	118	02.23112
	118	02.23113
	120	02.23114
	120	02.23115
	193	02.23153
	193	02.23154
	193	02.23155
	193	02.23156
	203	02.23160
	203	02.23161
	203	02.23162
	204	02.23163
	488	02.23228
	488	02.23229
	558	02.23240
	558	02.23241
	559	02.23242
	559	02.23243
	559	02.23244
	570	02.23245

Application	Page	Erqo No.
	571	02.23246
	571	02.23247
	635	02.23250
	635	02.23251
	635	02.23252
	635	02.23253
	657	02.23254
	661	02.23255
	664	02.23256
	262	02.23350
	263	02.23351
	342	02.23352
	342	02.23353
	342	02.23354
	343	02.23355
	343	02.23356
	343	02.23357
	343	02.23358
	343	02.23359
	343	02.23360
	344	02.23361
	344	02.23362
	344	02.23363
	344	02.23364
	344	02.23365
	344	02.23366
	345	02.23367
	345	02.23368
	345	02.23369
	345	02.23370
	345	02.23371
	345	02.23372
	346	02.23373
	346	02.23374
	354	02.23375
	354	02.23376
	430	02.23377
	430	02.23378
	638	02.23382

THE ORIGINAL NUMBERS OF THE VEHICLE MANUFACTURER MAY BE USED FOR COMPARISON PURPOSES ONLY AND MUST NOT BE MENTIONED ON INVOICES TO VEHICLE OWNERS.

Crankcase & Gasket Kit

Kurbelgehäuse & Dichtsatz • Carter & Kits de joints • Cártar - Bloque Motor & Kit de juntas
 Bloco & Jogo de junta • Картер и набор уплотнений

Application	Description	Details	Ref.	Erqo No.
OM 401 + A/LA, OM 421 + A/LA, OM 441 + A/LA	<ul style="list-style-type: none"> EN Crankcase DE Kurbelgehäuse FR Carter ES Bloque motor PT Bloco motor RU Блок-картер 		441 010 0208	02.19430

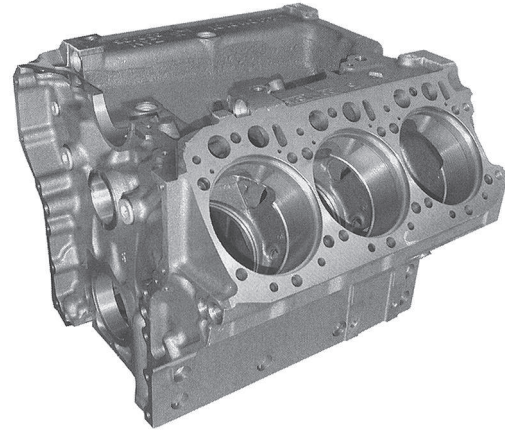

1

OM 401 + A/LA, OM 421 + A/LA, OM 441 + A/LA	<ul style="list-style-type: none"> EN General overhaul kit, complete with race rings DE Generalüberholsatz, komplett mit Laufringen FR Kit d'entretien, complet avec segments ES Kit de revision general, completo con anillos roda PT Jogo junta motor completo, com anéis pista RU Комплект капитального ремонта, в сборе с кольцами 		421 010 0408	02.19426
---	--	--	--------------	----------

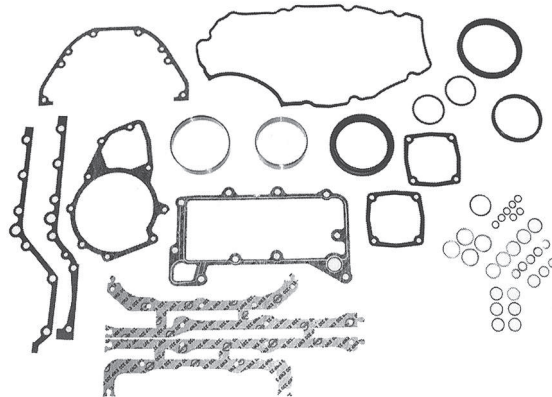

OM 402 + A/LA, OM 422 + A/LA, OM 442 + A/LA	<ul style="list-style-type: none"> EN Crankcase DE Kurbelgehäuse FR Carter ES Bloque motor PT Bloco motor RU Блок-картер 		442 010 0308	02.19431
---	--	--	--------------	----------

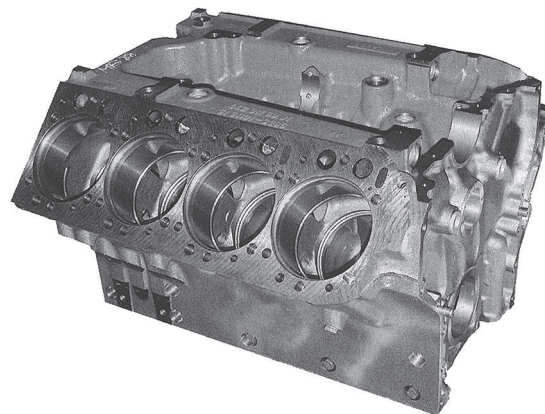

Crankcase & Gasket Kit

Kurbelgehäuse & Dichtsatz • Carter & Kits de joints • Cártier - Bloque Motor & Kit de juntas
 Bloco & Jogo de junta • Картер и набор уплотнений

Application	Description	Details	Ref.	Erqo No.
-------------	-------------	---------	------	----------

OM 402 + A/LA,
 OM 422 + A/LA,
 OM 442 + A/LA

- EN General overhaul kit, complete with race rings
- DE Generalüberholsatz, komplett mit Laufringen
- FR Kit d'entretien, complet avec segments
- ES Kit de revisión general, completo con anillos roda
- PT Jogo junta motor completo, com anéis pista
- RU Комплект капитального ремонта, в сборе с кольцами

422 010 0608

02.19428

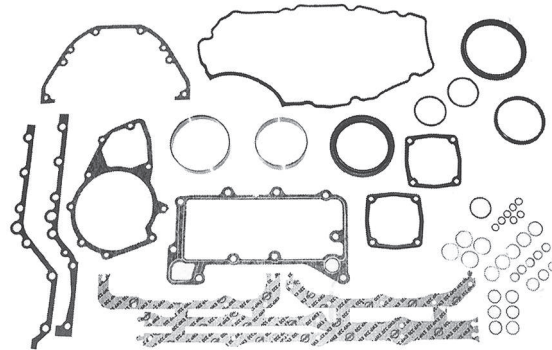

OM 403 + A/LA,
 OM 423 + A/LA,
 OM 443 + A/LA

- EN Crankcase
- DE Kurbelgehäuse
- FR Carter
- ES Bloque motor
- PT Bloco motor
- RU Блок-картер

443 010 0008

02.19432

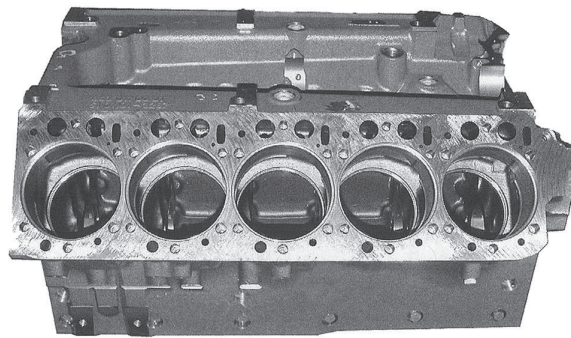

OM 403 + A/LA,
 OM 423 + A/LA,
 OM 443 + A/LA

- EN General overhaul kit, complete with race rings
- DE Generalüberholsatz, komplett mit Laufringen
- FR Kit d'entretien, complet avec segments
- ES Kit de revisión general, completo con anillos roda completo con anillos rodadura
- PT Jogo junta motor completo, com anéis pista
- RU Комплект капитального ремонта, в сборе с кольцами

423 010 0608

02.19429

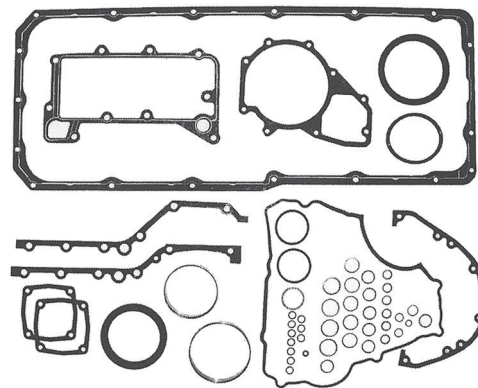

Crankcase & Gasket Kit







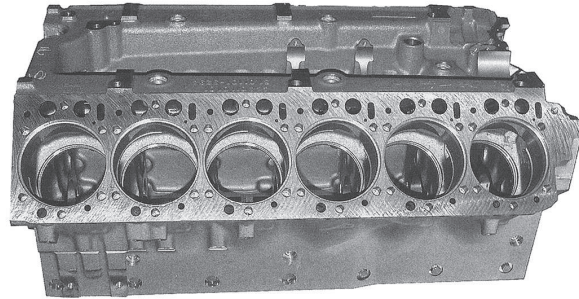

Kurbelgehäuse & Dichtsatz • Carter & Kits de joints • Cártar - Bloque Motor & Kit de juntas
 Bloco & Jogo de junta • Картер и набор уплотнений

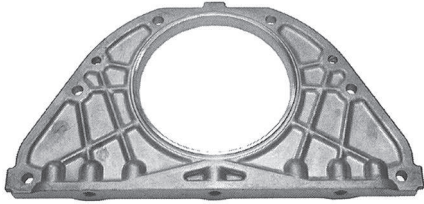





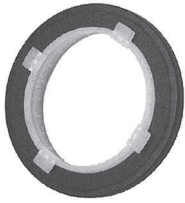



Application	Description	Details	Ref.	Erqo No.
OM 424 + A/LA, OM 444 + A/LA	<ul style="list-style-type: none"> EN Crankcase DE Kurbelgehäuse FR Carter ES Bloque motor PT Bloco motor RU Блок-картер 		444 010 0108	02.19433



1











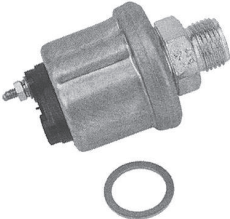

Application	Description	Details	Ref.	Erqo No.
OM 401 / 402 / 403 + A/LA, OM 421 / 422/423 + A/LA, OM 441 / 442 / 443 + A/LA	<ul style="list-style-type: none"> EN Cover, crankcase DE Deckel, Kurbelgehäuse FR Couvercle, carter ES Tapa, Bloque motor PT Tampa dianteira, bloco motor RU Крышка, Блок-картер 		403 011 0107	02.19470 
				
OM 401 / 402 / 403 + A/LA, OM 421 / 422/423 + A/LA, OM 441 / 442 / 443 + A/LA	<ul style="list-style-type: none"> EN Gasket DE Dichtung FR Joint ES Junta PT Junta RU Уплотнение 		442 011 0080	02.19486 
				
OM 401/402/403 + A/LA, OM 421/422/423 + A/LA, OM 441/442/443 + A/LA	<ul style="list-style-type: none"> EN Oil seal DE Wellendichtring FR Joint speed ES Anillo retén PT Retentor RU Сальник 	105 x 130 x 12	014 997 4647	02.22679 
				
OM 401/402/403 + A/LA, OM 421/422/423 + A/LA, OM 441/442/443 + A/LA	<ul style="list-style-type: none"> EN Oil seal DE Wellendichtring FR Joint speed ES Anillo retén PT Retentor RU Сальник 	100 x 130 x 11	013 997 1646	02.22643 
				
OM 401/421/441, OM 402/422/442, OM 403/423/443 -- motor 532629	<ul style="list-style-type: none"> EN Oil separator DE Ölabscheider FR Séparateur d'huile ES Separador de aceite PT Separador óleo RU Маслоотделитель 		000 018 3835	02.19548 
				

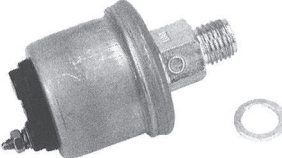
Application	Description	Details	Ref.	Erqo No.
OM 401/421/441 + A/LA, OM 402/422/442 + A/LA, OM 403/423/443 + A/LA motor 532630 --	EN Oil separator DE Ölabscheider FR Séparateur d'huile ES Separador de aceite PT Separador óleo RU Маслоотделитель		000 018 3735	02.19547 
				
OM 401/421/441 + A/LA, OM 402/422/442 + A/LA, OM 403/423/443 + A/LA	EN O-ring DE O-Ring FR Joint torique ES Junta tórica PT Anel RU Уплотнительное кольцо	36,0 x 3,0 mm	000 997 5348	02.22705 
				
OM 402, OM 403	EN Hose DE Schlauch FR Durite ES Manguera PT Mangueira RU Шланг		403 997 0082	02.22766 
				
OM 402, OM 403, OM 422, OM 423, OM 442, OM 443	EN Hose left-hand-drive DE Schlauch Linkslenkung FR Durite volant à gauche ES Manguito volante lado izquierda PT Mangueira volante lado esquerdo RU Шланг левостороннее управление		403 018 1182	02.19552 
				
OM 402, OM 403, OM 422, OM 423, OM 442, OM 443	EN Hose right-hand-drive DE Schlauch Rechtslenkung FR Durite volant à droite ES Manguito volante lado derecho PT Mangueira volante lado direito RU Шланг Правостороннее управление		403 018 1782	02.19553 
				





THE ORIGINAL NUMBERS OF THE VEHICLE MANUFACTURER MAY BE USED FOR COMPARISON PURPOSES ONLY AND MUST NOT BE MENTIONED ON INVOICES TO VEHICLE OWNERS.

Application	Description	Details	Ref.	Erqo No.
1 OM 422 A+LA, OM 442 A	(EN) Air vent tube (DE) Entlüfterrohr (FR) Durite ventilation (ES) Tubo de ventilación (PT) Tubo de ventilação (RU) Трубка		422 018 0012	02.19543 
OM 401 + LA, OM 402 + LA OM 403, OM 421 + A/LA, OM 422 + A/LA, OM 423 + A/LA OM 441, OM 442 + A/LA, OM 443 + A/LA	(EN) Pipe, oil seperator pipe (DE) Rohr, Ölabscheiderrohr (FR) Tuyau, séparateur d'huile (ES) Tubo, separador de aceite (PT) Cano, separador óleo (RU) Труба, Масляный сепаратор		403 011 0124	02.19481 
OM 401 LA, OM 441 LA	(EN) Hose, air vent (DE) Schlauch, Entlüftung (FR) Durite, ventilation (ES) Manguera, de ventilación (PT) Mangueira, ventilador ar (RU) Шланг, Вентиляция		441 018 0012	02.19544 
OM 402 LA, OM 442 A+LA	(EN) Hose, air vent (DE) Schlauch, Entlüftung (FR) Durite, ventilation (ES) Manguera, de ventilación (PT) Mangueira, ventilador ar (RU) Шланг, Вентиляция		442 018 0212	02.19545 
OM 401/402/403 + A/LA, OM 421/422/423 + A/LA, OM 441/442/443 + A/LA motor 736817--	(EN) Oil pressure sensor with warning contact (DE) Öldruckgeber mit Warnkontakt (FR) Manomètre huile avec avertissement de contact (ES) Sensor de presión de aceite con sensor de emergencia (PT) Sensor pressão óleo com contato de advertencia (RU) Датчик давления масла с устройством предупреждения контакта	0 - 5 bar 0,25 +-0,15 bar; M18 x 1,5 	002 542 1717	02.21895 

THE ORIGINAL NUMBERS OF THE VEHICLE MANUFACTURER MAY BE USED FOR COMPARISON PURPOSES ONLY AND MUST NOT BE MENTIONED ON INVOICES TO VEHICLE OWNERS.







Application	Description	Details	Ref.	Erqo No.
OM 401/402/403 + A/LA, OM 421/422/423 + A/LA, OM 441/442/443 + A/LA -- motor 736816	EN Oil pressure sensor DE Öldruckgeber FR Manomètre huile ES Sensor de presión de aceite PT Sensor pressão óleo RU Датчик давления масла	0 - 5 bar; M 18 x 1,5	004 542 4317	02.21897 
				
OM 401/402/403 + A/LA, OM 421/422/423 + A/LA, OM 441/442/443 + A/LA -- motor 736817	EN Oil pressure sensor DE Öldruckgeber FR Manomètre huile ES Sensor de presión de aceite PT Sensor pressão óleo RU Датчик давления масла	0 - 5 bar; M 14 x 1,5	004 542 8917	02.21899 
				
OM 401/402/403 + A/LA, OM 421/422/423 + A/LA, OM 441/442/443 + A/LA	EN Temperature sensor DE Temperatursensor FR Sonde de température ES Sensor de temperatura PT Sensor temperatura RU Температурный датчик	M 14 x 1,5 / 105 °C	004 542 5617	02.21898 
				
OM 401/402/403 + A/LA, OM 421/422/423 + A/LA, OM 441/442/443 + A/LA	EN Temperature sensor DE Temperatursensor FR Capteur de température ES Sensor de temperatura PT Sensor temperatura RU Температурный датчик	M 14 x 1,5 / 103 °C	003 153 9028	02.20071 
				
OM 401/402/403 + A/LA, OM 421/422/423 + A/LA, OM 441/442/443 + A/LA	EN Temperature sensor DE Temperatursensor FR Sonde de température ES Sensor de temperatura PT Sensor temperatura RU Температурный датчик	M 14 x 1,5 / 100 °C	002 542 7317	02.21896 
				
OM 441 LA Euro II, OM 442 LA Euro II	EN Temperature sensor DE Temperaturgeber FR Indicateur de température ES Transmisor de temperatura PT Sensor temperatura RU Температурный датчик	M 14 x 1,5 / 130 °C max	003 153 8428	02.20070 
				

THE ORIGINAL NUMBERS OF THE VEHICLE MANUFACTURER MAY BE USED FOR COMPARISON PURPOSES ONLY AND MUST NOT BE MENTIONED ON INVOICES TO VEHICLE OWNERS.

Application	Description	Details	Ref.	Erqo No.
OM 403	EN Temperature sensor DE Temperatursensor FR Sonde de température ES Sensor de temperatura PT Sensor temperatura RU Температурный датчик	M 14 x 1,5 / 97 °C	004 545 5524	02.22012 
				
OM 403	EN Temperature sensor DE Temperatursensor FR Sonde de température ES Sensor de temperatura PT Sensor temperatura RU Температурный датчик	M 14 x 1,5 / 120 °C max	001 542 2317	02.21894 
				
OM 401/421/441 + A/LA, OM 402/422/442 + A/LA, OM 403/423/443 + A/LA	EN Oil nozzle, complete DE Öldüse, komplett FR Gicleur d'huile, complet ES Tobera aceite, completo PT Injetor óleo, completo RU Масляная форсунка, в сборе		442 180 0543 S	02.23043 
				
OM 401/421/441 + A/LA, OM 402/422/442 + A/LA, OM 403/423/443 + A/LA	EN Oil nozzle, without hollow screw DE Öldüse, ohne Hohl-schraube FR Gicleur d'huile, sans vis banjo ES Inyector de aceite, sin perno hueco PT Esguicho pistão, sem parafuso vazado RU Масляная форсунка, без Пустотельный болт		442 180 0543	02.20126 
				
OM 401/421/441 + A/LA, OM 402/422/442 + A/LA, OM 403/423/443 + A/LA	EN Hollow screw DE Hohl-schraube FR Vis banjo ES Tornillo hueco PT Parafuso vazado RU Пустотельный болт		915036 010109	02.22979 
				
				Sample
OM 401/421/441 A/LA, OM 402/422/442 A/LA, OM 403/423/443 A/LA	EN Seal clamp DE Dichtklammer FR Agrafe d'étanchéité ES Grapa de cierre PT Abraçadeira RU Уплотнительный зажим		442 011 0082	02.19488 
				

Application	Description	Details	Ref.	Erqo No.
OM 401/421/441 + A/LA, OM 402/422/442 + A/LA, OM 403/423/443 + A/LA	<p>EN Screw crankcase cover at crankcase</p> <p>DE Schraube Kubelwellenlagerdeckel an Kurbelgehäuse</p> <p>FR Vis couvercle de carter sur carter</p> <p>ES Tornillo tapa cojiente bancada</p> <p>PT Parafuso tampa bloco motor</p> <p>RU Болт крышки картера к картеру</p>	M 18 x 2	422 011 0071	02.19485 
				
OM 401/421/441 + A/LA, OM 402/422/442 + A/LA, OM 403/423/443 + A/LA	<p>EN Cap</p> <p>DE Deckel</p> <p>FR Couvercle</p> <p>ES Tapa</p> <p>PT Tampa fechamento do comando</p> <p>RU Крышка</p>		403 011 0221	02.19480 
				
OM 401/421/441 + A/LA, OM 402/422/442 + A/LA, OM 403/423/443 + A/LA	<p>EN Drain plug</p> <p>DE Verschlusschraube</p> <p>FR Bouchon de vidange</p> <p>ES Tapón roscado</p> <p>PT Vujão</p> <p>RU Резьбовая пробка</p>	M 14 x 1,5	007604 014110	02.22882 
NG/MK/SK				
				
OM 401/421/441 + A/LA, OM 402/422/442 + A/LA, OM 403/423/443 + A/LA	<p>EN Copper washer</p> <p>DE Kupferdichtring</p> <p>FR Rondelle de cuivre</p> <p>ES Arandela de cobre</p> <p>PT Arruela vedação</p> <p>RU Уплотнительное кольцо медное</p>	14 x 18 x 1,5	007603 014102	02.22867 
				
OM 401/421/441 + A/LA, OM 402/422/442 + A/LA, OM 403/423/443 + A/LA	<p>EN Drain plug</p> <p>DE Verschlusschraube</p> <p>FR Bouchon de vidange</p> <p>ES Tapón roscado</p> <p>PT Vujão</p> <p>RU Резьбовая пробка</p>	M 16 x 1,5	000908 016008	02.22810 
				

THE ORIGINAL NUMBERS OF THE VEHICLE MANUFACTURER MAY BE USED FOR COMPARISON PURPOSES ONLY AND MUST NOT BE MENTIONED ON INVOICES TO VEHICLE OWNERS.

Application	Description	Details	Ref.	Erqo No.
1 OM 401/421/441 + A/LA, OM 402/422/442 + A/LA, OM 403/423/443 + A/LA	EN Copper washer DE Kupferdichtring FR Rondelle de cuivre ES Arandela de cobre PT Arruela vedação RU Уплотнительное кольцо медное	16 x 20 x 1,5	007603 016105	02.22868 
OM 401/421/441 + A/LA, OM 402/422/442 + A/LA, OM 403/423/443 + A/LA	EN Drain plug DE Verschlusschraube FR Bouchon de vidange ES Tapón PT Tampão RU Резьбовая пробка	M 26 x 1,5	000908 018010	02.22811 
OM 401/421/441 + A/LA, OM 402/422/442 + A/LA, OM 403/423/443 + A/LA	EN Copper washer DE Kupferdichtring FR Rondelle de cuivre ES Arandela de cobre PT Arruela vedação RU Уплотнительное кольцо медное	18 x 22 x 1,5	007603 018101	02.22870 
OM 401/421/441 + A/LA, OM 402/422/442 + A/LA, OM 403/423/443 + A/LA	EN Drain plug DE Verschlusschraube FR Bouchon de vidange ES Tapón PT Tampão RU Резьбовая пробка	M 18 x 1,5	000 997 3532	02.22596 
OM 401/421/441 + A/LA, OM 402/422/442 + A/LA, OM 403/423/443 + A/LA	EN Washer DE Kupferdichtring FR Rondelle ES Arandela PT Anel vedação RU Уплотнительное кольцо медное	26 x 31 x 2		
OM 401/421/441 + A/LA, OM 402/422/442 + A/LA, OM 403/423/443 + A/LA	EN Drain plug DE Verschlusschraube FR Bouchon de vidange ES Tapón roscado PT Tampão RU Резьбовая пробка	M 30 x 1,5	000908 030002	02.22812 

Application	Description	Details	Ref.	Erqo No.
OM 401/421/441 + A/LA, OM 402/422/442 + A/LA, OM 403/423/443 + A/LA	EN Copper washer DE Kupferdichtring FR Rondelle de cuivre ES Arandela de cobre PT Anel vedação RU Уплотнительное кольцо	30 x 36 x 2	007603 030101	02.22872 
				
OM 401/402/403 -- motor 129760	EN Dowel pin DE Fixierhülse FR Douille de fixation ES Casquillo de fijación PT Bucha fixação RU Фиксационная гильза		000 991 1341	02.22527 
				
OM 401/402/403 -- motor 129760; OM 401/402/403 A/LA, OM 421/441 + A/LA, OM 422/442 + A/LA OM 423/443 + A/LA	EN Dowel pin DE Fixierhülse FR Douille de fixation ES Casquillo de fijación PT Guia cabeçote RU Фиксационная гильза		107 991 0041	02.22528 
				
OM 401/421/441 + A/LA, OM 402/422/442 + A/LA, OM 403/423/443 + A/LA	EN Fitting DE Stutzen FR Raccord ES Racor PT Conector RU Патрубок	M 14 x 1,5 / M 16 x 1,5	403 997 1172	02.22748 
				
OM 401/421/441 + A/LA, OM 402/422/442 + A/LA, OM 403/423/443 + A/LA	EN Plug DE Verschlussdeckel FR Bouchon ES Tapa de cierre PT Tampa vedação RU Крышка	Ø 34,2 mm	000443 034002	02.22805 
				
OM 401/421/441 + A/LA, OM 402/422/442 + A/LA, OM 403/423/443 + A/LA	EN Expansion plug DE Verschlussdeckel FR Bouchon ES Tapa de cierre PT Tampa vedação RU Крышка, диаметр	Ø 40 mm	000 997 4320	02.22580 
				

THE ORIGINAL NUMBERS OF THE VEHICLE MANUFACTURER MAY BE USED FOR COMPARISON PURPOSES ONLY AND MUST NOT BE MENTIONED ON INVOICES TO VEHICLE OWNERS.

1

Application	Description	Details	Ref.	Erqo No.
OM 401/421/441 + A/LA, OM 402/422/442 + A/LA, OM 403/423/443 + A/LA -- motor 650332, -- motor 707584, -- motor 793992	<ul style="list-style-type: none"> EN Timing case DE Steuergehäuse FR Carter de distribution ES Cártér de distribución PT Carcaça embreagem RU Картер маховика 		423 010 5033	02.19451 

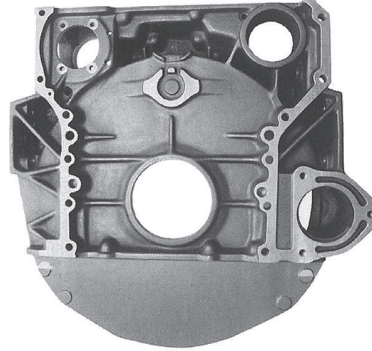

OM 401/421/441 + A/LA, OM 402/422/442 + A/LA, OM 403/423/443 + A/LA motor 707585 --, motor 794007 --	<ul style="list-style-type: none"> EN Timing case DE Steuergehäuse FR Carter de distribution ES Cártér de distribución PT Carcaça embreagem RU Картер маховика 		423 010 0033	02.19448 
---	--	--	--------------	---

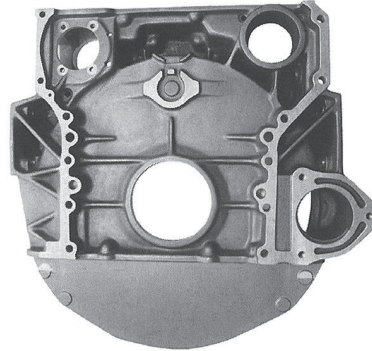



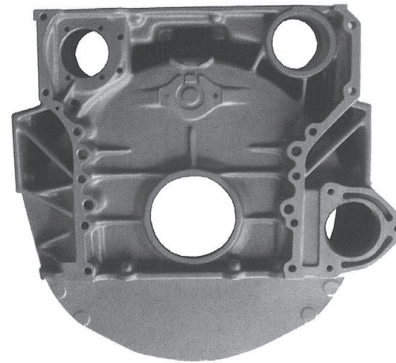





OM 442 LA (440.971/975/976), motor 707585 --	<ul style="list-style-type: none"> EN Timing case DE Steuergehäuse FR Carter de distribution ES Cártér de distribución PT Carcaça embreagem RU Картер маховика 		423 010 0133	02.19449 
--	--	--	--------------	---



OM 401/421/441 + A/LA, OM 402/422/442 + A/LA, OM 403/423/443 + A/LA	<ul style="list-style-type: none"> EN Gasket DE Dichtung FR Joint ES Junta PT Junta RU Уплотнение 		442 015 0060	02.19501 
--	---	--	--------------	---

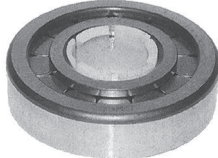

Application	Description	Details	Ref.	Erqo No.
OM 401/421/441 + A/LA, OM 402/422/442 + A/LA, OM 403/423/443 + A/LA	EN Gasket kit DE Dichtsatz FR Kit de joints ES Juego de juntas PT Jogo junta RU Комплект уплотнителей		423 010 4833	02.19450 
				
OM 401/402/403 + A/LA, OM 421/422/423 + A/LA, OM 441/442/443 + A/LA	EN Oil seal DE Wellendichtring FR Bague d'étanchéité ES Anillo retén PT Retentor RU Сальник	120 x 140 x 13 / 12	013 997 1447	02.22671 
				
OM 401/421/441 + A/LA, OM 402/422/442 + A/LA, OM 403/423/443 + A/LA -- motor 650332, -- motor 707584, -- motor 793992	EN Bracket, compressor bearing DE Halter, Kompressorlager FR Support, Compresseur palier ES Sujeción, Cojinete del compresor PT Suporte, compressor RU Кронштейн, Подшипник компрессора		403 015 0950	02.19500 
				
OM 401/421/441 + A/LA, OM 402/422/442 + A/LA, OM 403/423/443 + A/LA -- motor 650332, -- motor 707584, -- motor 793992	EN Roller bearing DE Rollenlager FR Palier à rouleaux ES Rodamiento de rodillos PT Rolamento RU Роликоподшипник		007 981 3001	02.22326 
				
OM 401/421/441 + A/LA, OM 402/422/442 + A/LA, OM 403/423/443 + A/LA -- motor 650332, -- motor 707584, -- motor 793992	EN Bracket DE Halter FR Support ES Sujeción PT Tampa rolamento RU Кронштейн		403 015 0045	02.19499 
				

THE ORIGINAL NUMBERS OF THE VEHICLE MANUFACTURER MAY BE USED FOR COMPARISON PURPOSES ONLY AND MUST NOT BE MENTIONED ON INVOICES TO VEHICLE OWNERS.

1

Application	Description	Details	Ref.	Erqo No.
OM 401/402/403 + A/LA, OM 421/422/423 + A/LA, OM 441/442/443 + A/LA	<p>EN Bearing housing</p> <p>DE Lagergehäuse</p> <p>FR Palier de compresseur</p> <p>ES Cojinete del compresor</p> <p>PT Flange carcaça distribuição</p> <p>RU Подшипник компрессора</p>		442 130 0045	02.23044

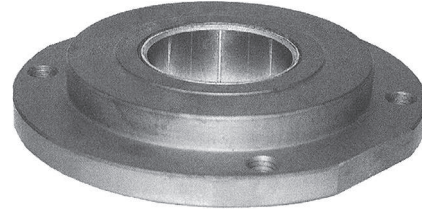

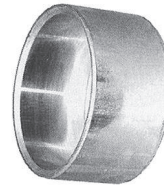

OM 401/402/403 + A/LA, OM 421/422/423 + A/LA, OM 441/442/443 + A/LA	<p>EN Bushing new version</p> <p>DE Buchse neue Ausführung</p> <p>FR Bague nouvelle version</p> <p>ES Casquillo nueva versión</p> <p>PT Bucha nova versão</p> <p>RU Втулка новая версия</p>		442 131 0150	02.19982
---	---	--	--------------	----------

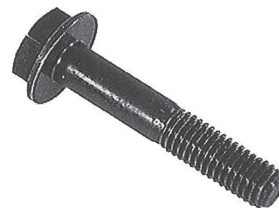

OM 401 / 402 / 403 + A/LA, OM 421 / 422/423 + A/LA, OM 441 / 442 / 443 + A/LA	<p>EN Screw timing case at crankcase old version</p> <p>DE Schraube Steuergehäuse an Kurbelgehäuse alte Ausführung</p> <p>FR Vis carter de distribution sur carter de vilebrequin ancienne version</p> <p>ES Tornillo cártar de distribución a bloque motor version antigua</p> <p>PT Parafuso capa seca na caixa de marcha versão antiga</p> <p>RU Болт картер рулевого механизма к картеру двигателя старое исполнение</p>	M 22 x 1,5	403 990 0304	02.22441
---	--	------------	--------------	----------



Application	Description	Details	Ref.	Erqo No.
OM 401 /402/403 + A/LA, OM 421 /422/423 + A/LA, OM 441 /442/443 + A/LA	<p>EN Screw timing case at crankcase new version</p> <p>DE Schraube Steuergehäuse an Kurbelgehäuse neue Ausführung</p> <p>FR Vis carter de distribution sur carter de vilebrequin nouvelle version</p> <p>ES Tornillo cáster de distribución a bloque motor nueva versión</p> <p>PT Parafuso capa seca na caixa de marcha nova versão</p> <p>RU Болт картер рулевого механизма к картеру двигателя нового типа</p>	57 mm	423 990 0004	02.22443 
OM 401 /402/403 + A/LA, OM 421 /422/423 + A/LA, OM 441 /442/443 + A/LA	<p>EN Screw timing case at crankcase, only for old timing case</p> <p>DE Schraube Steuergehäuse an Kurbelgehäuse, nur bei altem Kurbelgehäuse</p> <p>FR Vis carter de distribution sur carter de vilebrequin, pour ancienne version de carter de manivelle</p> <p>ES Tornillo cáster de distribución a bloque motor, solo para carcasa de motor antigua</p> <p>PT Parafuso capa seca na caixa de marcha, somente para carcaça velha</p> <p>RU Болт картер рулевого механизма к картеру двигателя, только у старого картера</p>		403 990 0504	02.22442 
OM 401/421/441 + A/LA, OM 402/422/442 + A/LA, OM 403/423/443 + A/LA	<p>EN Plug</p> <p>DE Stopfen</p> <p>FR Bouchon</p> <p>ES Tapón</p> <p>PT Tampão</p> <p>RU Заглушка</p>		403 997 0086	02.22773 

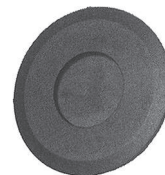

Application	Description	Details	Ref.	Erqo No.
OM 402/442 LA	<ul style="list-style-type: none"> EN Oil sump DE Ölwanne FR Carter d'huile ES Cártér de aceite PT Cártér óleo RU Масляный поддон 		442 010 2913	02.19434

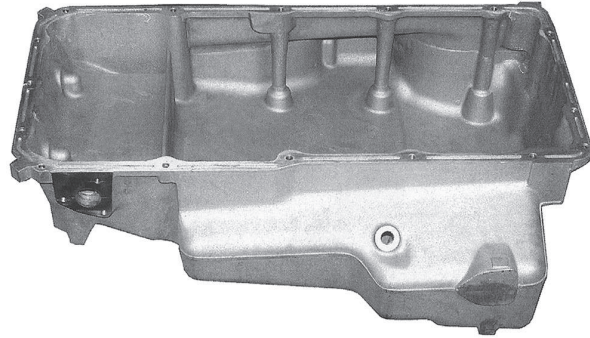

OM 401/421/441 + A/LA	<ul style="list-style-type: none"> EN Gasket kit, oil sump DE Dichtsatz, Ölwanne FR Kit de joints, carter d'huile ES Juego de juntas, cárter de aceite PT Jogo junta, carter RU Комплект уплотнителей, Масляный поддон 		441 014 0422 S	02.23047
-----------------------	--	--	----------------	----------

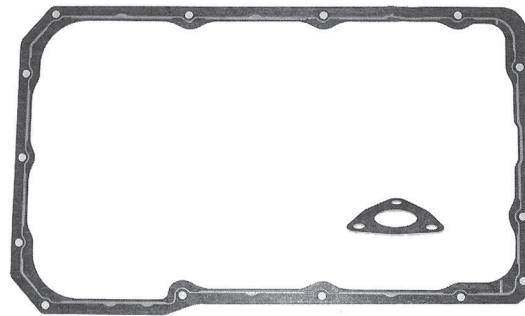



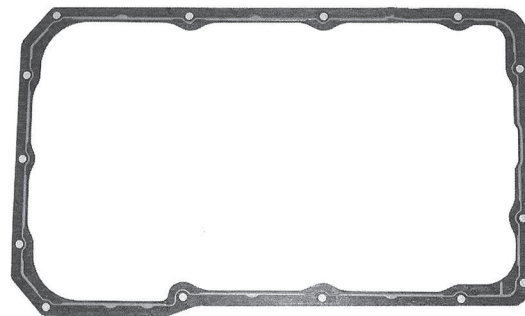



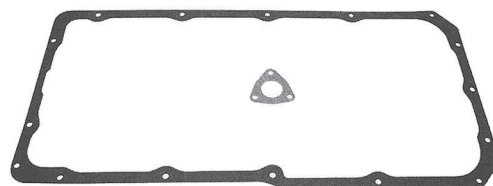

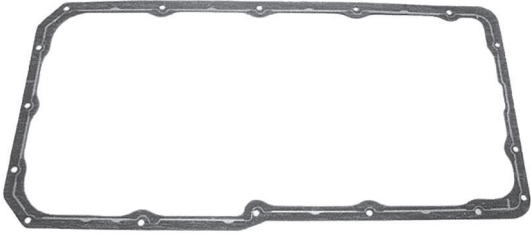

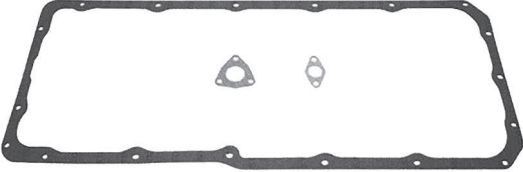
OM 401/421/441 + A/LA	<ul style="list-style-type: none"> EN Oil sump gasket DE Ölwannendichtung FR Joint de carter d'huile ES Junta del cárter de aceite PT Junta cárter óleo RU Уплотнение масляного поддона 		441 014 0422	02.19495
-----------------------	---	--	--------------	----------

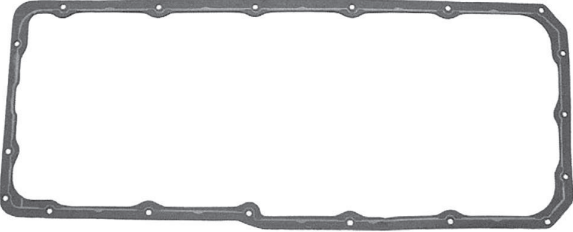

OM 402/422/442 + A/LA	<ul style="list-style-type: none"> EN Gasket kit, oil sump DE Dichtsatz, Ölwanne FR Kit de joints, carter d'huile ES Juego de juntas, cárter de aceite PT Jogo junta, carter óleo RU Комплект уплотнителей, Масляный поддон 		442 014 1122 S	02.23046
-----------------------	---	--	----------------	----------







Application	Description	Details	Ref.	Erqo No.
OM 402/422/442 + A/LA	<ul style="list-style-type: none"> EN Oil sump gasket DE Ölwannendichtung FR Joint de carter d'huile ES Junta del cárter de aceite PT Junta cárter óleo RU Уплотнение масляного поддона 		442 014 1122	02.19497 
OM 403/423/443 + A/LA	<ul style="list-style-type: none"> EN Gasket kit, oil sump DE Dichtsatz, Ölwanne FR Kit de joints, carter d'huile ES Juego de juntas, cárter de aceite PT Jogo junta, carter óleo RU Комплект уплотнителей, Масляный поддон 		443 014 0022 S	02.23048 
OM 403/423/443 + A/LA	<ul style="list-style-type: none"> EN Oil sump gasket DE Ölwannendichtung FR Joint de carter d'huile ES Junta del cárter de aceite PT Junta cárter óleo RU Уплотнение масляного поддона 		443 014 0022	02.19498 
OM 401/421/441 + A/LA, OM 402/422/442 + A/LA, OM 403/423/443 + A/LA	<ul style="list-style-type: none"> EN Gasket DE Dichtung FR Joint ES Junta PT Junta RU Уплотнение 		442 018 0080	02.19550 
OM 403/423/443 + A/LA	<ul style="list-style-type: none"> EN Gasket, turbocharger DE Dichtung, Turbolader FR Joint, turbocompresseur ES Junta, turbocompresor PT Junta, turbo RU Уплотнение, Турбоагнетатель 		447 187 0080	02.20139 

THE ORIGINAL NUMBERS OF THE VEHICLE MANUFACTURER MAY BE USED FOR COMPARISON PURPOSES ONLY AND MUST NOT BE MENTIONED ON INVOICES TO VEHICLE OWNERS.





Application	Description	Details	Ref.	Erqo No.
OM 401 / 402 / 403 + A/LA, OM 421 / 422/423 + A/LA, OM 441 / 442 / 443 + A/LA	<ul style="list-style-type: none"> EN Drain plug, with magnet DE Verschlusschraube, mit Magnet FR Bouchon de vidange, avec aimant ES Tapón roscado, con imán PT Bujão, magnético RU Резьбовая пробка, с магнитом 	M 26 x 1,5	403 997 0032	02.22602 
				
OM 401 / 402 / 403 + A/LA, OM 421 / 422/423 + A/LA, OM 441 / 442 / 443 + A/LA	<ul style="list-style-type: none"> EN Drain plug, without magnet DE Verschlusschraube, ohne Magnet FR Bouchon de vidange, sans aimant ES Tapón roscado, sin imán PT Bujão, non magnético RU Резьбовая пробка, без магнита 	M 26 x 1,5	403 997 0230	02.23045 
				
OM 401/402/403 + A/LA, OM 421/422/423 + A/LA, OM 441/442/443 + A/LA	<ul style="list-style-type: none"> EN Oil filler cap, metal old version DE Öleinfülldeckel, Metall alte Ausführung FR Bouchon de remplissage d'huile, métal ancienne version ES Tapón de llenado de aceite, metal versión antigua PT Tampa combustível, metal versão antiga RU Крышка горловины, металл старое исполнение 		000 018 0702	02.19541 
				
OM 401 / 402 / 403 + A/LA, OM 421 / 422/423 + A/LA, OM 441 / 442/443 + A/LA	<ul style="list-style-type: none"> EN Seal ring DE Dichtring FR Bague d'étanchéité ES Anillo obturador PT Anel camisa RU Уплотнительное кольцо 		102 018 0380	02.19549 
				
OM 401/402/403 + A/LA, OM 421/422/423 + A/LA, OM 441/442/443 + A/LA	<ul style="list-style-type: none"> EN Oil filler cap, plastic new version DE Öleinfülldeckel, Kunststoff neue Ausführung FR Bouchon de remplissage d'huile, plastique nouvelle version ES Tapón de llenado de aceite, plástico nueva versión PT Tampa reservatório óleo, plástico nova versão RU Крышка горловины, Пластик нового типа 		111 018 0302	02.19542 
				

THE ORIGINAL NUMBERS OF THE VEHICLE MANUFACTURER MAY BE USED FOR COMPARISON PURPOSES ONLY AND MUST NOT BE MENTIONED ON INVOICES TO VEHICLE OWNERS.

Application	Description	Details	Ref.	Erqo No.
OM 422 A BM 942/956/958; OM 422 LA BM 953/955/959	<ul style="list-style-type: none"> EN Oil dipstick DE Ölmesstab FR Jauge de niveau d'huile ES Varilla de medición del aceite PT Vareta óleo RU Маслоизмерительный щуп 	1228 mm	422 010 0072	02.19458 
OM 401/402/403, OM 421/422/423, OM 422 A BM 954/957	<ul style="list-style-type: none"> EN Oil dipstick DE Ölmesstab FR Jauge de niveau d'huile ES Varilla de medición del aceite PT Vareta óleo RU Маслоизмерительный щуп 	980 mm	403 010 3372	02.19457 
OM 441/442/443, OM 441 LA BM951; OM 442 A	<ul style="list-style-type: none"> EN Oil dipstick DE Ölmesstab FR Jauge de niveau d'huile ES Varilla de medición del aceite PT Vareta óleo RU Маслоизмерительный щуп 	1048 mm	422 010 1872	02.19459 
OM 401 LA, OM 402 LA BM 978/983/996; OM 441 LA, OM 442 LA BM446	<ul style="list-style-type: none"> EN Oil dipstick old version DE Ölmesstab alte Ausführung FR Jauge de niveau d'huile ancienne version ES Varilla de medición del aceite version antigua PT Vareta óleo versão anterior RU Маслоизмерительный щуп старая версия 	1270 mm	441 010 0072	02.19460 

THE ORIGINAL NUMBERS OF THE VEHICLE MANUFACTURER MAY BE USED FOR COMPARISON PURPOSES ONLY AND MUST NOT BE MENTIONED ON INVOICES TO VEHICLE OWNERS.

1

Application	Description	Details	Ref.	Erqo No.
OM 401/402 LA, OM 441 LA, OM 442 LA BM446	<ul style="list-style-type: none"> EN Oil dipstick new version DE Ölmesstab neue Ausführung FR Jauge de niveau d'huile nouvelle version ES Varilla de medición del aceite nueva versión PT Vareta óleo nova versão RU Маслоизмерительный щуп новая версия 	1300 mm	442 010 3272	02.19462 
OM 401 LA BM 970/974; OM 402 LA BM 970/974/984/995	<ul style="list-style-type: none"> EN Oil dipstick DE Ölmesstab FR Jauge de niveau d'huile ES Varilla de medición del aceite PT Vareta óleo RU Маслоизмерительный щуп 	900 mm	442 010 0672	02.19461 
OM 401/402/403, OM 421/422/423, OM 422 A BM 954/957	<ul style="list-style-type: none"> EN Guide pipe, oil dipstick DE Führungsrohr, Ölmesstab FR Tube de guidage, jauge de niveau d'huile ES Tubo guía, varilla de medición del aceite PT Tubo guia, vareta óleo RU Направляющая трубка 		403 010 3166	02.19454 
OM 441/442/443, OM 441 LA BM 951; OM 442 A	<ul style="list-style-type: none"> EN Guide pipe, oil dipstick DE Führungsrohr, Ölmesstab FR Tube de guidage, jauge de niveau d'huile ES Tubo guía, varilla de medición del aceite PT Tubo guia, vareta óleo RU Направляющая трубка 		442 010 2466	02.19456 

Application	Description	Details	Ref.	Erqo No.
OM 402 LA, OM 441 LA BM 445; OM 442 LA, BM446 OM 401/441 LA motor 742633 --	EN Guide pipe, oil dipstick DE Führungsrohr, Ölmesstab FR Tube de guidage, jauge de niveau d'huile ES Tubo guía, varilla de medición del aceite PT Tubo guia, vareta óleo RU Направляющая трубка		442 010 1366	02.19455 
BM 387/389, 393/395, BM 620/621/622	EN Radiator hose DE Kühlerschlauch FR Durite de radiateur ES Manguito PT Mangueira radiador RU Патрубок радиатора		387 528 0582	02.21855 
BM 387/389, 395	EN Radiator hose DE Kühlerschlauch FR Durite de radiateur ES Manguito PT Mangueira radiador RU Патрубок радиатора		387 528 0482	02.21854 
BM 383/385/387/389, 395 BM617, BM 621	EN Radiator hose DE Kühlerschlauch FR Durite de radiateur ES Manguito PT Mangueira radiador RU Патрубок радиатора		402 018 0482	02.19551 
BM 620/621/622/623/ 624/625, BM 645/646/647/648/649, BM 652/653/654/655/ 656/657/658/659	EN Hose DE Schlauch FR Durite ES Tubo flexible PT Mangueira RU Патрубок		620 528 0282	02.21858 
BM 616/617/619, BM 621, 625/625, BM 646, 649, BM 652/653/654/655/656, 659	EN Hose DE Schlauch FR Durite ES Tubo flexible PT Mangueira RU Патрубок		620 528 0182	02.21857 

THE ORIGINAL NUMBERS OF THE VEHICLE MANUFACTURER MAY BE USED FOR COMPARISON PURPOSES ONLY AND MUST NOT BE MENTIONED ON INVOICES TO VEHICLE OWNERS.

1

Application	Description	Details	Ref.	Erqo No.
BM 620/621/622/623/624	<ul style="list-style-type: none"> EN Hose DE Schlauch FR Durite ES Tubo flexible PT Mangueira RU Патрубок 		620 528 0082	02.21856 



BM 620/621/622/623/624, B M 645/646, 648/649, B M 655/656, 658/659 (-- 5 421333)	<ul style="list-style-type: none"> EN Hose DE Schlauch FR Durite ES Tubo flexible PT Mangueira RU Патрубок 		620 528 0482	02.21859 
--	--	--	--------------	---









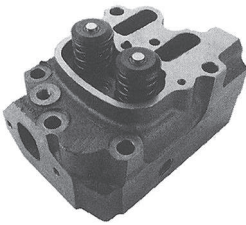

BM 625/655/656/657, 658/659	<ul style="list-style-type: none"> EN Hose DE Schlauch FR Durite ES Tubo flexible PT Mangueira RU Патрубок 		655 528 0382	02.21867 
-----------------------------------	--	--	--------------	---

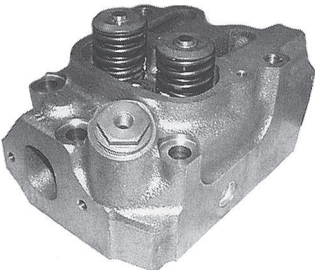

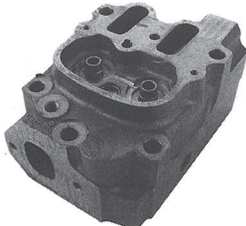

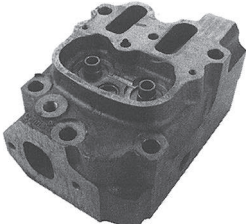
B M 645/646, 648/649, BM 655/656, 658/659 (5 421334 --)	<ul style="list-style-type: none"> EN Hose DE Schlauch FR Durite ES Tubo flexible PT Mangueira RU Патрубок 		620 528 0582	02.21860 
---	--	--	--------------	---



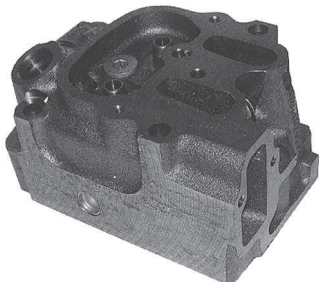

Application	Description	Details	Ref.	Erqo No.
OM 401/421/441 + A/LA, OM 402/422/442 + A/LA, OM 403/423/443 + A/LA	<ul style="list-style-type: none"> EN Cylinder head, complete DE Zylinderkopf, komplett FR Culasse, complet ES Culata, completa PT Cabeçote, completo RU Головка блока цилиндров, в сборе 		429 010 0220 S	02.23050 
OM 441.991; OM 441 LA BM 445; OM 442.901/999; OM 442 LA B M 446	<ul style="list-style-type: none"> EN Cylinder head, complete with constant throttle DE Zylinderkopf, komplett mit Konstantdrossel FR Culasse, complet avec étrangleur ES Culata, completa con estrangulador constante PT Cabeçote, completo com acel. constante RU Головка блока цилиндров, в сборе с дроссель 		442 010 0620 S	02.23049 
OM 401/421/441 + A/LA, OM 402/422/442 + A/LA, OM 403/423/443 + A/LA	<ul style="list-style-type: none"> EN Cylinder head DE Zylinderkopf FR Culasse ES Culata PT Cabeçote RU Головка блока цилиндров 		429 010 0220	02.19443 
OM 401, OM 402, OM 421, OM 422, OM 423, OM 441, OM 442, OM 443	<ul style="list-style-type: none"> EN Cylinder head DE Zylinderkopf FR Culasse ES Culata PT Cabeçote RU Головка блока цилиндров 		442 010 0720	02.19445 







THE ORIGINAL NUMBERS OF THE VEHICLE MANUFACTURER MAY BE USED FOR COMPARISON PURPOSES ONLY AND MUST NOT BE MENTIONED ON INVOICES TO VEHICLE OWNERS.

Application	Description	Details	Ref.	Erqo No.
OM 441.991; OM 441 LA B M 445; OM 442.901/999; OM 442 LA BM 446	<p>EN Cylinder head with constant throttle</p> <p>DE Zylinderkopf mit Konstantdrossel</p> <p>FR Culasse avec étrangleur</p> <p>ES Culata con estrangulador constante</p> <p>PT Cabeçote com acel. constante</p> <p>RU Головка блока цилиндров с дроссель</p>		442 010 0620	02.19444 

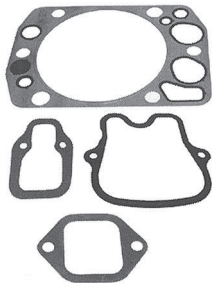

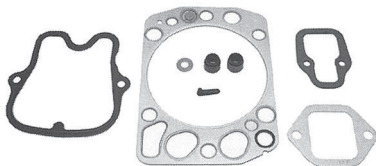

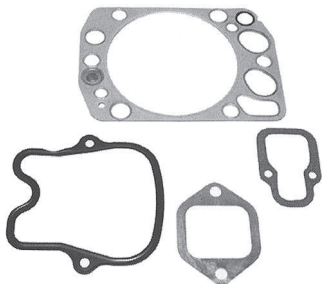



OM 401/402 LA, OM 441 LA, OM 442/443+A/LA	<p>EN Valve cover</p> <p>DE Ventildeckel</p> <p>FR Couvercle de soupape</p> <p>ES Cubierta de válvulas</p> <p>PT Tampa de válvula</p> <p>RU Крышка клапана</p>		442 016 0505	02.19507 
---	--	--	--------------	--

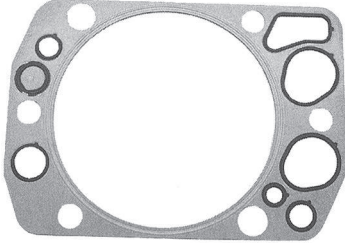

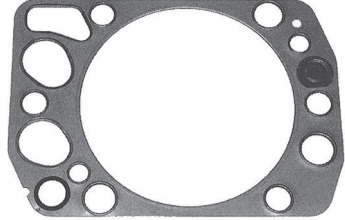

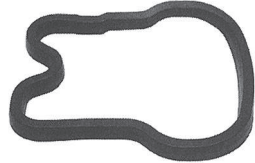

OM 401/421/441 + A/LA, OM 402/422/442 + A/LA, OM 403/423/443 + A/LA	<p>EN Cylinder head gasket kit including cylinder head gasket (Viton-rings)</p> <p>DE Zylinderkopfdichtsatz enthält Zylinderkopfdichtung (Viton-Ringe)</p> <p>FR Pochette de joint de culasse incluyant joint de culasse (anneaux viton)</p> <p>ES Juego de juntas de culata incluye junta de cilindro (anillos de viton)</p> <p>PT Jogo junta cabeçote incluso junta cabeçote (aneis de viton)</p> <p>RU Комплект прокладок ГБЦ содержит прокладку для головки цилиндра (кольцам из витона)</p>		442 016 0320 S	02.23051 
---	--	--	----------------	---

THE ORIGINAL NUMBERS OF THE VEHICLE MANUFACTURER MAY BE USED FOR COMPARISON PURPOSES ONLY AND MUST NOT BE MENTIONED ON INVOICES TO VEHICLE OWNERS.

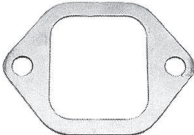





Application	Description	Details	Ref.	Erqo No.
OM 401/421/441 + A/LA, OM 402/422/442 + A/LA, OM 403/423/443 + A/LA	<p>EN Cylinder head gasket kit including cylinder head gasket (Viton-rings)</p> <p>DE Zylinderkopfdichtsatz enthält Zylinderkopfdichtung (Viton-Ringe)</p> <p>FR Pochette de joint de culasse incluyant joint de culasse (anneaux viton)</p> <p>ES Juego de juntas de culata incluye junta de cilindro (anillos de viton)</p> <p>PT Jogo junta cabeçote incluso junta cabeçote (anéis de viton)</p> <p>RU Комплект прокладок ГБЦ содержит прокладку для головки цилиндра (кольцам из витона)</p>		444 010 0120	02.19446 
OM 401/421/441 + A/LA, OM 402/422/442 + A/LA, OM 403/423/443 + A/LA	<p>EN Gasket kit, cylinder head including cylinder head gasket (copper rings)</p> <p>DE Dichtsatz, Zylinderkopf enthält Zylinderkopfdichtung (Kupferringe)</p> <p>FR Pochette de joint de culasse incluyant joint de culasse (anneaux cuivre)</p> <p>ES Juego de juntas de culata incluye junta de cilindro (anillos de cobre)</p> <p>PT Jogo junta cabeçote incluso junta cabeçote (anéis de cobre)</p> <p>RU Комплект уплотнителей содержит прокладку для головки цилиндра (медные кольца)</p>		422 016 0420 S	02.23053 
OM 401/421/441 + A/LA, OM 402/422/442 + A/LA, OM 403/423/443 + A/LA	<p>EN Gasket kit, cylinder head including cylinder head gasket (copper rings)</p> <p>DE Dichtsatz, Zylinderkopf enthält Zylinderkopfdichtung (Kupferringe)</p> <p>FR Pochette de joint de culasse incluyant joint de culasse (anneaux cuivre)</p> <p>ES Juego de juntas de culata incluye junta de cilindro (anillos de cobre)</p> <p>PT Jogo junta cabeçote incluso junta cabeçote (aneis de cobre)</p> <p>RU Комплект уплотнителей содержит прокладку для головки цилиндра (медные кольца)</p>		423 010 0220	02.19439 

THE ORIGINAL NUMBERS OF THE VEHICLE MANUFACTURER MAY BE USED FOR COMPARISON PURPOSES ONLY AND MUST NOT BE MENTIONED ON INVOICES TO VEHICLE OWNERS.











Application	Description	Details	Ref.	Erqo No.
OM 401/421/441 + A/LA, OM 402/422/442 + A/LA, OM 403/423/443 + A/LA	<p>EN Cylinder head gasket with viton seal rings</p> <p>DE Zylinderkopfdichtung mit Viton Dichtringen</p> <p>FR Joint de culasse avec anneaux viton</p> <p>ES Junta de culata con juntas de vitón</p> <p>PT Junta cabeçote com aneis de viton</p> <p>RU Прокладка ГБЦ с кольцам из ВИТОНА</p>		442 016 0320	02.19513 
OM 401/421/441 + A/LA, OM 402/422/442 + A/LA, OM 403/423/443 + A/LA	<p>EN Cylinder head gasket with copper seal rings - old version</p> <p>DE Zylinderkopfdichtung mit Kupferdichtringen - alte Ausführung</p> <p>FR Joint de culasse avec rondelles de cuivre - ancienne version</p> <p>ES Junta de culata con juntas de cobre - versión antigua</p> <p>PT Junta cabeçote com aneis de cobre - versão anterior</p> <p>RU Прокладка ГБЦ с медные кольца - старая версия</p>		422 016 0420	02.19509 
OM 401/421/441 + A/LA, OM 402/422/442 + A/LA, OM 403/423/443 + A/LA	<p>EN Valve cover gasket</p> <p>DE Ventildeckeldichtung</p> <p>FR Joint de cache culbuteur</p> <p>ES Junta de la tapa de válvula</p> <p>PT Junta tampa válvula</p> <p>RU Уплотнение клапанного механизма</p>		442 016 0621	02.19517 
OM 401/421/441 + A/LA, OM 402/422/442 + A/LA, OM 403/423/443 + A/LA	<p>EN Valve cover gasket old version</p> <p>DE Ventildeckeldichtung alte Ausführung</p> <p>FR Joint de cache culbuteur ancienne version</p> <p>ES Junta de la tapa de válvula versión antigua</p> <p>PT Junta tampa válvula versão antiga da</p> <p>RU Уплотнение клапана старая версия</p>		403 016 0121	02.19515 

Application	Description	Details	Ref.	Erqo No.
OM 401/421/441 + A/LA, OM 402/422/442 + A/LA, OM 403/423/443 + A/LA	<p>EN Gasket exhaust manifold</p> <p>DE Dichtung Abgaskrümmer</p> <p>FR Joint collecteur gaz d'échappement</p> <p>ES Junta colector de escape</p> <p>PT Junta colector de escape</p> <p>RU Уплотнение Выпускной коллектор</p>		403 142 0380	02.20036 
OM 401/421/441 + A/LA, OM 402/422/442 + A/LA, OM 403/423/443 + A/LA	<p>EN Gasket intake manifold</p> <p>DE Dichtung Einlasskrümmer</p> <p>FR Joint collecteur d'admission</p> <p>ES Junta colector de admisión</p> <p>PT Junta colector de admissão</p> <p>RU Уплотнение Впускной коллектор</p>		442 141 1780	02.20029 
OM 401/421/441 + A/LA, OM 402/422/442 + A/LA, OM 403/423/443 + A/LA	<p>EN Rubber cap</p> <p>DE Gummikappe</p> <p>FR Bouchon</p> <p>ES Tapa de cierre</p> <p>PT Sara borracha</p> <p>RU Крышка</p>		403 016 0061	02.19521 
OM 401/421/441 + A/LA, OM 402/422/442 + A/LA, OM 403/423/443 + A/LA	<p>EN Expansion plug</p> <p>DE Verschlussdeckel</p> <p>FR Bouchon</p> <p>ES Tapa de cierre</p> <p>PT Tampa vedação</p> <p>RU Крышка</p>	Ø 22 mm	403 997 0720	02.22585 
OM 401/421/441 + A/LA, OM 402/422/442 + A/LA, OM 403/423/443 + A/LA	<p>EN Expansion plug</p> <p>DE Verschlussdeckel</p> <p>FR Bouchon</p> <p>ES Tapa de cierre</p> <p>PT Tampa vedação</p> <p>RU Крышка, диаметр</p>	Ø 40 mm	000 997 4320	02.22581 

THE ORIGINAL NUMBERS OF THE VEHICLE MANUFACTURER MAY BE USED FOR COMPARISON PURPOSES ONLY AND MUST NOT BE MENTIONED ON INVOICES TO VEHICLE OWNERS.









Application	Description	Details	Ref.	Erqo No.
1 OM 401/421/441 + A/LA, OM 402/422/442 + A/LA, OM 403/423/443 + A/LA	(EN) Sleeve, nozzle holder (DE) Hülse, Düsenhalter (FR) Douille, support gicleur (ES) Manguito, Portainyector (PT) Casquilho, bico (RU) Втулка, Корпус форсунки		403 017 0271	02.19540 
OM 401/421/441 + A/LA, OM 402/422/442 + A/LA, OM 403/423/443 + A/LA	(EN) Washer (DE) Scheibe (FR) Rondelle (ES) Arandela (PT) Arruela (RU) Шайба, Толщина	9,5 x 20 x 1 	388 017 0160	02.19539 
OM 401/421/441 + A/LA, OM 402/422/442 + A/LA, OM 403/423/443 + A/LA	(EN) Copper washer (DE) Kupferscheibe (FR) Rondelle de cuivre (ES) Arandela de cobre (PT) Arruela cobre (RU) Медная шайба	9,5 x 20 x 1,5 	346 017 0260	02.19538 
OM 401/421/441 + A/LA, OM 402/422/442 + A/LA, OM 403/423/443 + A/LA	(EN) Cylinder head screw cylinder head to crankcase (DE) Zylinderkopfschraube Zylinderkopf an Kurbelgehäuse (FR) Vis de culasse culasse sur bloc (ES) Tornillo de culata culata con carter cigüeñal (PT) Parafuso cabeçote aberto cabeça motor (RU) Болт крепления ГБЦ ГБЦ к блоку цилиндров	168 mm 	422 990 0401	02.22429 
OM 401/421/441 + A/LA, OM 402/422/442 + A/LA, OM 403/423/443 + A/LA	(EN) Cylinder head screw cylinder head to crankcase (DE) Zylinderkopfschraube Zylinderkopf an Kurbelgehäuse (FR) Vis de culasse culasse sur bloc (ES) Tornillo de culata culata con carter cigüeñal (PT) Parafuso cabeçote aberto cabeça motor (RU) Болт крепления ГБЦ ГБЦ к блоку цилиндров	144 mm 	422 990 0301	02.22428 





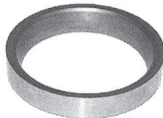





THE ORIGINAL NUMBERS OF THE VEHICLE MANUFACTURER MAY BE USED FOR COMPARISON PURPOSES ONLY AND MUST NOT BE MENTIONED ON INVOICES TO VEHICLE OWNERS.

Application	Description	Details	Ref.	Erqo No.
OM 401/421/441 + A/LA, OM 402/422/442 + A/LA, OM 403/423/443 + A/LA	<p>EN Cylinder head screw cylinder head to crankcase</p> <p>DE Zylinderkopfschraube Zylinderkopf an Kurbelgehäuse</p> <p>FR Vis de culasse culasse sur bloc</p> <p>ES Tornillo de culata culata con carter cigüeñal</p> <p>PT Parafuso cabeçote aperto cabeça motor</p> <p>RU Болт крепления ГБЦ ГБЦ к блоку цилиндров</p>	109 mm	422 990 0201	02.22427 
				
OM 402 (- motor 088408)	<p>EN Kit, valve seat rings</p> <p>DE Satz, Ventilsitzringe</p> <p>FR Kit, siège de soupape</p> <p>ES Juego, Anillos de asiento de válvula</p> <p>PT Jogo, sede válvula</p> <p>RU Комплект, Кольца седла клапана</p>	53,11 mm / 60,11 mm	442 053 0032 S1	02.23052 
				
OM 402 motor 088409-, OM 422/442 + A/LA	<p>EN Kit, valve seat rings</p> <p>DE Satz, Ventilsitzringe</p> <p>FR Kit, siège de soupape</p> <p>ES Juego, Anillos de asiento de válvula</p> <p>PT Jogo, sede válvula</p> <p>RU Комплект, Кольца седла клапана</p>	53,11 mm / 60,11 mm	442 053 0032 S2	02.23054 
				
OM 401/402 LA	<p>EN Kit, valve seat rings</p> <p>DE Satz, Ventilsitzringe</p> <p>FR Kit, siège de soupape</p> <p>ES Juego, Anillos de asiento de válvula</p> <p>PT Jogo, sede válvula</p> <p>RU Комплект, Кольца седла клапана</p>	53,11 mm / 60,11 mm	442 053 0032 S3	02.23055 
				
OM 403 motor 088409 --, OM 423/443 + A/LA	<p>EN Kit, valve seat rings</p> <p>DE Satz, Ventilsitzringe</p> <p>FR Kit, siège de soupape</p> <p>ES Juego, Anillos de asiento de válvula</p> <p>PT Jogo, sede válvula</p> <p>RU Комплект, Кольца седла клапана</p>	53,11 mm / 60,11 mm	442 053 0032 S4	02.23056 
				

THE ORIGINAL NUMBERS OF THE VEHICLE MANUFACTURER MAY BE USED FOR COMPARISON PURPOSES ONLY AND MUST NOT BE MENTIONED ON INVOICES TO VEHICLE OWNERS.

Application	Description	Details	Ref.	Erqo No.
OM 401/402 LA, OM 421/422/423 A/LA, OM 441/442/443 A/LA	<ul style="list-style-type: none"> EN Valve seat ring DE Ventil Sitzring FR Siège de soupape ES Anillo de asiento de válvula PT Sede válvula RU Кольцо седла клапана 		442 053 0132	02.19754 
OM 421/441 A/LA, OM 422/442 A/LA, OM 423/443 A/LA	<ul style="list-style-type: none"> EN Valve seat ring DE Ventil Sitzring FR Siège de soupape ES Anillo de asiento de válvula PT Sede válvula RU Кольцо седла клапана 		422 053 0631	02.19747 
OM 401/421/441 + A/LA, OM 402/422/442 + A/LA, OM 403/423/443 + A/LA	<ul style="list-style-type: none"> EN Valve seat ring DE Ventil Sitzring FR Siège de soupape ES Anillo de asiento de válvula PT Sede válvula RU Кольцо седла клапана 		422 053 0731	02.19748 
OM 401/402 LA, OM 421/422/423 A/LA, OM 441/442/443 A/LA	<ul style="list-style-type: none"> EN Valve seat ring DE Ventil Sitzring FR Siège de soupape ES Anillo de asiento de válvula PT Sede válvula RU Кольцо седла клапана 		442 053 0232	02.19755 
OM 401/402/403 -- motor 088408	<ul style="list-style-type: none"> EN Valve seat ring, intake DE Ventil Sitzring, Einlass FR Siège de soupape, admission ES Anillo de asiento de válvula, Admisión PT Sede válvula, admissão RU Кольцо седла клапана, Впуск 	61,11 mm 	403 053 0331	02.19742 
OM 401/402/403 motor 088409 --; OM 401/402/403 A/LA, OM 421/441 + A/LA, OM 422/442 + A/LA, OM 423/443 +A/LA	<ul style="list-style-type: none"> EN Valve seat ring, intake DE Ventil Sitzring, Einlass FR Siège de soupape, admission ES Anillo de asiento de válvula, Admisión PT Sede válvula, admissão RU Кольцо седла клапана, Впуск 	60,11 mm 	422 053 0531	02.19746 









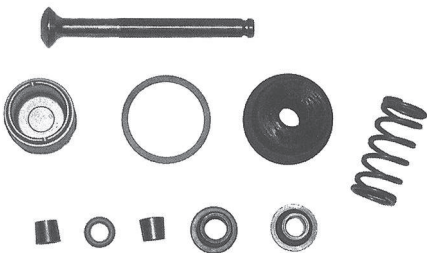

Application	Description	Details	Ref.	Erqo No.
OM 401/402 LA (Euro I)	<ul style="list-style-type: none"> EN Valve seat ring, intake DE Ventil Sitzring, Einlass FR Siège de soupape, admission ES Anillo de asiento de válvula, Admisión PT Sede válvula, admissão RU Кольцо седла клапана, Впуск 	60,11 mm	402 053 0131	02.19741 
				
OM 441/442 A/LA	<ul style="list-style-type: none"> EN Valve seat ring, intake DE Ventil Sitzring, Einlass FR Siège de soupape, admission ES Anillo de asiento de válvula, Admisión PT Sede válvula, admissão RU Кольцо седла клапана, Впуск 	60,11 mm	442 053 0531	02.19749 
				
OM 401/402/403 LA, OM 421/422/423 A/LA, OM 441/442/443 A/LA	<ul style="list-style-type: none"> EN Valve seat ring, exhaust DE Ventil Sitzring, Auslass FR Siège de soupape, échappement ES Anillo de asiento de válvula, escape PT Sede válvula, escape RU Кольцо седла клапана, Выпуск 	53,11 mm	442 053 0032	02.19753 
				
OM 401 + A + LA, OM 421 + A + L A , OM 441 + A + LA	<ul style="list-style-type: none"> EN Kit, valve guides DE Satz, Ventilführungen FR Jeu, Guide de soupape ES Juego, Guías de válvula PT Jogo, guia válvula RU Комплект, Направл. клапанов 		422 053 0430 S	02.23057 
				
OM 402 + A + LA, OM 422 + A + LA, OM 442 + A + LA	<ul style="list-style-type: none"> EN Kit, valve guides DE Satz, Ventilführungen FR Jeu, Guide de soupape ES Juego, Guías de válvula PT Jogo, guia válvula RU Комплект, Направл. клапанов 		422 053 0430 S1	02.23058 
				

Application	Description	Details	Ref.	Erqo No.
OM 403 + A + LA, OM 423 + A + LA, OM 443 + A + LA	<ul style="list-style-type: none"> EN Kit, valve guides DE Satz, Ventilführungen FR Jeu, Guide de soupape ES Juego, Guías de válvula PT Jogo, guia válvula RU Комплект, Направл. клапанов 		422 053 0430 S2	02.23059 
OM 401/421/441 + A/LA, OM 402/422/442 + A/LA, OM 403/423/443 + A/LA	<ul style="list-style-type: none"> EN Valve guide, intake and exhaust DE Ventilführung, Einlass und Auslass FR Guide de soupape, Admission et échappement ES Guía de válvula, admisión y escape PT Guia válvula, admissão e escape RU Направляющая клапана, Впуск и выпуск 		422 053 0430	02.19740 
OM 401/421/441 + A/LA, OM 402/422/442 + A/LA, OM 403/423/443 + A/LA	<ul style="list-style-type: none"> EN Valve stem seal DE Ventilschaftabdichtung FR Joint de guide de soupape ES Sellado del vastago de la válvula PT Vedador válvula RU Уплотнение стержня клапана 		422 053 0196	02.19759 
OM 401/421/441 + A/LA, OM 402/422/442 + A/LA, OM 403/423/443 + A/LA	<ul style="list-style-type: none"> EN Intake valve DE Einlassventil FR Soupape d'admission ES Válvula de admisión PT Válvula admissão RU Впускной клапан 		442 050 0526	02.19719 
OM 401/421/441 + A/LA, OM 402/422/442 + A/LA, OM 403/423/443 + A/LA	<ul style="list-style-type: none"> EN Exhaust valve DE Auslassventil FR Soupape d'échappement ES Válvula de escape PT Válvula escape RU Выпускной клапан 		442 050 0227	02.19722 

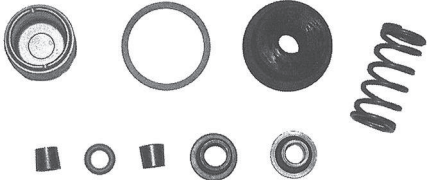
Application	Description	Details	Ref.	Erqo No.
OM 401/421/441 + A/LA, OM 402/422/442 + A/LA, OM 403/423/443 + A/LA --motor 803273	<p>EN Valve spring, outer</p> <p>DE Ventilfeder, außen</p> <p>FR Ressort de soupape, externe</p> <p>ES Resorte de válvula, exterior</p> <p>PT Mola válvula, externa</p> <p>RU Пружина клапана, внешн.</p>		403 053 0120	02.19727 
OM 401/421/441 + A/LA, OM 402/422/442 + A/LA, OM 403/423/443 + A/LA --motor 803273	<p>EN Valve spring, inner</p> <p>DE Ventilfeder, innen</p> <p>FR Ressort de soupape, interne</p> <p>ES Resorte de válvula, interior</p> <p>PT Mola válvula, interna</p> <p>RU Пружина клапана, внутр.</p>		403 053 0622	02.19731 
OM 401/421/441 + A/LA, OM 402/422/442 + A/LA, OM 403/423/443 + A/LA motor 803274--	<p>EN Valve spring, outer reinforced</p> <p>DE Ventilfeder, außen verstärkt</p> <p>FR Ressort de soupape, externe renforcé</p> <p>ES Resorte de válvula, exterior reforzado</p> <p>PT Mola válvula, externa reforçado</p> <p>RU Пружина клапана, внешн. усиленный</p>		403 053 1020	02.19729 
OM 401/421/441 + A/LA, OM 402/422/442 + A/LA, OM 403/423/443 + A/LA motor 803274--	<p>EN Valve spring, inner reinforced</p> <p>DE Ventilfeder, innen verstärkt</p> <p>FR Ressort de soupape, interne renforcé</p> <p>ES Resorte de válvula, interior reforzado</p> <p>PT Mola válvula, interna reforçado</p> <p>RU Пружина клапана, внутр. усиленный</p>		403 053 1120	02.19730 







THE ORIGINAL NUMBERS OF THE VEHICLE MANUFACTURER MAY BE USED FOR COMPARISON PURPOSES ONLY AND MUST NOT BE MENTIONED ON INVOICES TO VEHICLE OWNERS.

Application	Description	Details	Ref.	Erqo No.
1 OM 401/421/441 + A/LA, OM 402/422/442 + A/LA, OM 403/423/443 + A/LA	(EN) Shim inner (DE) Ausgleichscheibe innen (FR) Cale Interne (ES) Arandela de ajuste Interior (PT) Arruela ajuste interna (RU) Компенсационная шайба внутр.	30 x 20,2 x 0,5	403 053 0052	02.19756 
				
OM 401/421/441 + A/LA, OM 402/422/442 + A/LA, OM 403/423/443 + A/LA	(EN) Shim outer (DE) Ausgleichscheibe außen (FR) Cale externe (ES) Arandela de ajuste exterior (PT) Arruela ajuste externa (RU) Компенсационная шайба внешн.	42 x 32 x 0,5	403 053 0152	02.19757 
				
OM 401/402/403 + A/LA -- motor 265214; OM 421/422/423 + A/LA -- motor 139487	(EN) Spring retainer (DE) Federteller (FR) Siège ressort (ES) Goma (PT) Prato mola válvula (RU) Тарелка пружины		403 053 0325	02.19734 
				
OM 401/402/403 + A/LA motor 265215--; OM 421/422/423 + A/LA motor 139488--; OM 441/442/443 + A/LA	(EN) Spring retainer (DE) Federteller (FR) Siège ressort (ES) Goma (PT) Prato mola válvula (RU) Тарелка пружины		422 053 0025	02.19735 
				
OM 401/402/403 + A/LA -- motor 265214; OM 421/422/423 + A/LA -- motor 139487	(EN) Valve stem key (DE) Kegelstück (FR) Clavette (ES) Pieza cónica (PT) Chaveta da válvula (RU) Конический сухарь		000 053 0426	02.19736 
				

Application	Description	Details	Ref.	Erqo No.
OM 401/402/403 + A/LA motor 265215--; OM 421/422/423 + A/LA motor 139488--; OM 441/442/443 + A/LA	<p>EN Valve stem key</p> <p>DE Kegelstück</p> <p>FR Clavette</p> <p>ES Pieza cónica</p> <p>PT Chaveta da válvula</p> <p>RU Конический сухарь</p>		422 053 0026	02.19738 
OM 441.991; OM 441 LA BM 445; OM 442.901/999; OM 442 LA BM 446	<p>EN Repair kit, constant throttle</p> <p>DE Reparatursatz, Konstantdrossel</p> <p>FR Kit de réparation, étrangleur</p> <p>ES Kit de reparación, top brake</p> <p>PT Jogo reparo, acel. constante</p> <p>RU Ремонтный комплект, Нерегулируемый дроссель</p>		541 016 0490 S1	02.23060 
OM 441.991; OM 441 LA BM 445; OM 442.901/999; OM 442 LA B M 446	<p>EN Repair kit, constant throttle without valve</p> <p>DE Reparatursatz, Konstantdrossel ohne Ventil</p> <p>FR Kit de réparation, étrangleur sans soupape</p> <p>ES Kit de reparación, estrangulador constante sin válvula</p> <p>PT Jogo reparo, acel. constante sem válvula</p> <p>RU Ремонтный комплект, Нерегулируемый дроссель без клапана</p>		541 016 0490 S2	02.23061 
OM 441.991; OM 441 LA BM 445; OM 442.901/999; OM 442 LA BM 446	<p>EN Valve, constant throttle</p> <p>DE Ventil, Konstantdrossel</p> <p>FR Soupape, étrangleur</p> <p>ES Válvula, estrangulador constante</p> <p>PT Válvula, acel. constante</p> <p>RU Клапан, дроссель</p>		442 016 0391	02.19527 
OM 442.993/994	<p>EN Valve, constant throttle</p> <p>DE Ventil, Konstantdrossel</p> <p>FR Soupape, étrangleur</p> <p>ES Válvula, estrangulador constante</p> <p>PT Válvula, acel. constante</p> <p>RU Клапан, дроссель</p>		442 016 0191	02.19525 

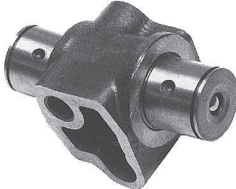
THE ORIGINAL NUMBERS OF THE VEHICLE MANUFACTURER MAY BE USED FOR COMPARISON PURPOSES ONLY AND MUST NOT BE MENTIONED ON INVOICES TO VEHICLE OWNERS.









Application	Description	Details	Ref.	Erqo No.
1 OM 441.991; OM 441 LA BM 445; OM 442.901/999; OM 442 LA BM 446	EN Piston, with seal ring DE Kolben, mit Dichtring FR Piston, avec bague d'étanchéité ES Pistón, con anillo de obturación PT Pistão, com anel RU Поршень, с уплотнительным кольцом		541 016 0490	02.19524 
OM 441.991; OM 441 LA BM 445; OM 442.901/999; OM 442 LA BM 446	EN Spring retainer DE Federteller FR Siège ressort ES Goma PT Arruela guia RU Тарелка пружины		442 016 0026	02.19518 
OM 441.991; OM 441 LA BM 445; OM 442.901/999; OM 442 LA BM 446	EN Guide DE Führung FR Guide ES Guía PT Guia RU Направляющая		442 016 0028	02.19519 
OM 441.991; OM 441 LA BM 445; OM 442.901/999; OM 442 LA BM 446	EN Spring DE Feder FR Ressort ES Resorte PT Mola espiral RU Пружина		442 993 5101	02.22544 
OM 441.991; OM 441 LA B M 445; OM 442.901/999; OM 442 LA BM 446	EN Valve collet DE Ventilkegelstück FR Clavette de soupape ES Pieza del cono de válvula PT Trava válvula RU Сухарь клапана		102 053 0026	02.19737 
OM 441.991; OM 441 LABM445; OM 442.901/999; OM 442 LA BM 446	EN Drain plug DE Verschlusschraube FR Bouchon de vidange ES Tapón roscado PT Vujão RU Резьбовая пробка		442 016 0071	02.19523 

Application	Description	Details	Ref.	Erqo No.
OM 441.991; OM 441 LA BM 445; OM 442.901/999; OM 442 LA BM 446	EN Seal ring DE Dichtring FR Bague d'étanchéité ES Retén PT Anel RU Уплотнительное кольцо		020 997 7747	02.22699 
OM 401/421/441 + A/LA, OM 402/422/442 + A/LA, OM 403/423/443 + A/LA	EN Rocker arm bracket, complete DE Kipphebelbock, komplett FR Palier de culbuteur, complet ES Soporte de balancín, completo PT Suporte balancim, completo RU Стойка оси коромысла, в сборе		403 050 1436	02.19726 
OM 401/421/441 + A/LA, OM 402/422/442 + A/LA, OM 403/423/443 + A/LA	EN Rocker arm bracket DE Kipphebelbock FR Palier de culbuteur ES Soporte de balancín PT Suporte balancim RU Стойка оси коромысла		403 050 1236	02.19725 
OM 401/421/441 + A/LA, OM 402/422/442 + A/LA, OM 403/423/443 + A/LA	EN Rocker arm DE Kipphebel FR Culbuteur ES Balancín PT Balanceiro válvula RU Коромысло		442 050 0333	02.19724 
OM 401/402/403 + A/LA, OM 421/422/423 + A/LA, OM 441/442/443 + A/LA	EN Bushing DE Buchse FR Bague ES Casquillo PT Bucha para RU Втулка		403 055 0650	02.19764 

THE ORIGINAL NUMBERS OF THE VEHICLE MANUFACTURER MAY BE USED FOR COMPARISON PURPOSES ONLY AND MUST NOT BE MENTIONED ON INVOICES TO VEHICLE OWNERS.



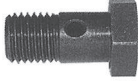





1

Application	Description	Details	Ref.	Erqo No.
OM 401/421/441 + A/LA, OM 402/422/442 + A/LA, OM 403/423/443 + A/LA	EN Mounting kit DE Befestigungssatz FR Jeu de fixations ES Juego de fijación PT Kit montagem RU Крепежный комплект		403 055 0220 S	02.23063 
OM 401/421/441 + A/LA, OM 402/422/442 + A/LA, OM 403/423/443 + A/LA	EN Adjusting screw DE Einstellschraube FR Vis de réglage ES Tornillo de ajuste PT Prisioneiro RU Установочный винт		403 055 0220	02.23062 
OM 401/421/441 + A/LA, OM 402/422/442 + A/LA, OM 403/423/443 + A/LA	EN Nut DE Mutter FR Ecrou ES Tuerca PT Porca RU Гайка	M 12 x 1	422 990 0051	02.22475 
OM 401/403 motor 002487 --, OM 401/421/441 + A/LA, OM 402/422/442 + A/LA, OM 403/423/443 + A/LA	EN Washer DE Scheibe FR Rondelle ES Arandela PT Arruela RU Шайба		001 990 8240	02.22468 
OM 401/403 -- motor 002486	EN Washer DE Scheibe FR Rondelle ES Arandela PT Arruela RU Шайба		000 991 0065	02.22530 
OM 401/421/441 + A/LA, OM 402/422/442 + A/LA, OM 403/423/443 + A/LA	EN Lock ring DE Sicherungsring FR Clip de verouillage ES Anillo de seguridad PT Anel trava RU Стопорное кольцо		000471 024000	02.22806 

Application	Description	Details	Ref.	Erqo No.
OM 401/421/441 + A/LA, OM 402/422/442 + A/LA, OM 403/423/443 + A/LA	<ul style="list-style-type: none"> EN Screw DE Schraube FR Vis ES Tornillo PT Parafuso RU Болт 	M 10 x 70, 12.9	000931 010369	02.22821 
				
OM 442 LA	<ul style="list-style-type: none"> EN Air pressure pipe, right DE Druckluftrohr, rechts FR Tube d'air de pression, droite ES Tubo de aire comprimido, derecho PT Tubo pressão ar, direito RU Трубопровод сжатого воздуха, прав. 		442 010 0055	02.19452 
				
OM 442 LA	<ul style="list-style-type: none"> EN Air pressure pipe, left DE Druckluftrohr, links FR Tube d'air de pression, gauche ES Tubo de aire comprimido, izquierdo PT Tubo pressão ar, esquerdo RU Трубопровод сжатого воздуха, лев. 		442 010 0355	02.19453 
				
OM 442 LA	<ul style="list-style-type: none"> EN Hollow screw DE Hohlschraube FR Vis banjo ES Perno hueco PT Parafuso vazado RU Пустотельный болт 	M 12 x 1,5	442 990 5563	02.22485 
				
OM 401 LA Euro I OM 402 LA Euro I OM 441 LA OM 442	<ul style="list-style-type: none"> EN Injector DE Düsenstock FR Injecteur ES Inyector PT Injetor RU Эмульсионная трубка 		004 017 1621	02.19536 
				

THE ORIGINAL NUMBERS OF THE VEHICLE MANUFACTURER MAY BE USED FOR COMPARISON PURPOSES ONLY AND MUST NOT BE MENTIONED ON INVOICES TO VEHICLE OWNERS.

1

Application	Description	Details	Ref.	Erqo No.
OM 441 A+LA OM 442 A+LA OM 443 A+LA	<ul style="list-style-type: none"> EN Injector DE Düsenstock FR Injecteur ES Inyector PT Injetor RU Эмульсионная трубка 		003 017 5821	02.19535 
OM 441 A+LA OM 442 A+LA OM 443 A+LA	<ul style="list-style-type: none"> EN Injection nozzle DE Einspritzdüse FR Gicleur injection ES Inyector PT Bico injetor RU Форсунка 		001 017 5112	02.19528 
OM 441 A+LA OM 442 A+LA OM 443 A+LA	<ul style="list-style-type: none"> EN Injection nozzle DE Einspritzdüse FR Gicleur injection ES Inyector PT Bico injetor RU Форсунка 		002 017 0912	02.19531 
OM 401 LA Euro I OM 402 LA Euro I OM 441 LA OM 442 A	<ul style="list-style-type: none"> EN Injection nozzle DE Einspritzdüse FR Gicleur injection ES Inyector PT Bico injetor RU Форсунка 		002 017 8812	02.19533 
OM 441 OM442 OM 443	<ul style="list-style-type: none"> EN Injection nozzle DE Einspritzdüse FR Nez d'injecteur ES Inyector PT Bico injetor RU Форсунка 		001 017 6012	02.19529 

THE ORIGINAL NUMBERS OF THE VEHICLE MANUFACTURER MAY BE USED FOR COMPARISON PURPOSES ONLY AND MUST NOT BE MENTIONED ON INVOICES TO VEHICLE OWNERS.

Application	Description	Details	Ref.	Erqo No.
OM 401 +A (Euro 0)	<ul style="list-style-type: none"> EN Crankshaft, without bearings DE Kurbelwelle, ohne Lager FR Vilebrequin, sans coussinets ES Cigüeñal, sin cojinetes PT Virabrequim, sem rolamentos RU Коленвал, без подшипника 		401 030 1901	02.19554
OM 441 motor 519686 --	<ul style="list-style-type: none"> EN Crankshaft, without bearings DE Kurbelwelle, ohne Lager FR Vilebrequin, sans coussinets ES Cigüeñal, sin cojinetes PT Virabrequim, sem rolamentos RU Коленвал, без подшипника 		441 030 2201	02.19572
OM 401 LA (Euro I)	<ul style="list-style-type: none"> EN Crankshaft, without bearings DE Kurbelwelle, ohne Lager FR Vilebrequin, sans coussinets ES Cigüeñal, sin cojinetes PT Virabrequim, sem rolamentos RU Коленвал, без подшипника 		401 030 2501	02.19555
OM 441 A/LA	<ul style="list-style-type: none"> EN Crankshaft, without bearings DE Kurbelwelle, ohne Lager FR Vilebrequin, sans coussinets ES Cigüeñal, sin cojinete PT Virabrequim, sem rolamentos RU Коленвал, без подшипника 		441 030 2101	02.19571

THE ORIGINAL NUMBERS OF THE VEHICLE MANUFACTURER MAY BE USED FOR COMPARISON PURPOSES ONLY AND MUST NOT BE MENTIONED ON INVOICES TO VEHICLE OWNERS.

Application	Description	Details	Ref.	Erqo No.
OM 421 + A/LA --motor 493529	<ul style="list-style-type: none"> EN Crankshaft, without bearings DE Kurbelwelle, ohne Lager FR Vilebrequin, sans coussinets ES Cigüeñal, sin cojinetes PT Virabrequim, sem rolamentos RU Коленвал, без подшипника 		421 030 2501	02.19562

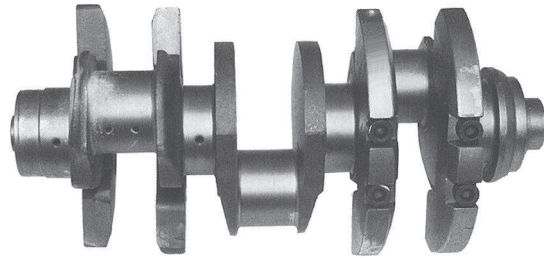

OM 421 + A/LA motor 493530 --	<ul style="list-style-type: none"> EN Crankshaft, without bearings DE Kurbelwelle, ohne Lager FR Vilebrequin, sans coussinets ES Cigüeñal, sin cojinetes PT Virabrequim, sem rolamentos RU Коленвал, без подшипника 		421 030 2401	02.19561
----------------------------------	---	--	--------------	----------

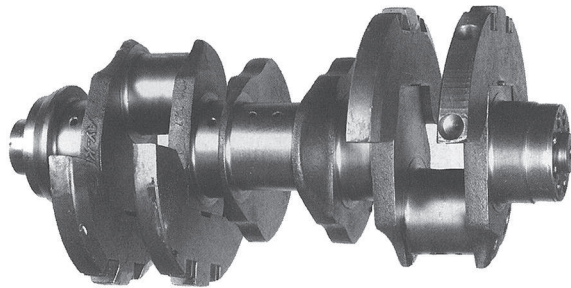



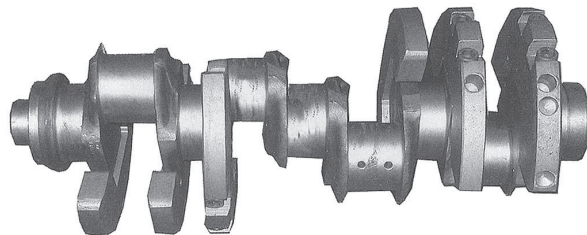



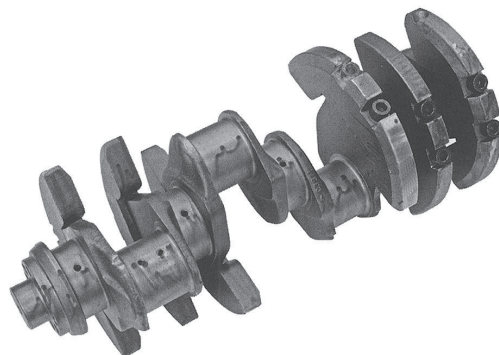

OM 402 + A/LA (Euro O/I)	<ul style="list-style-type: none"> EN Crankshaft, without bearings DE Kurbelwelle, ohne Lager FR Vilebrequin, sans coussinets ES Cigüeñal, sin cojinetes PT Virabrequim, sem rolamentos RU Коленвал, без подшипника 		402 030 3201	02.19559
-----------------------------	---	--	--------------	----------

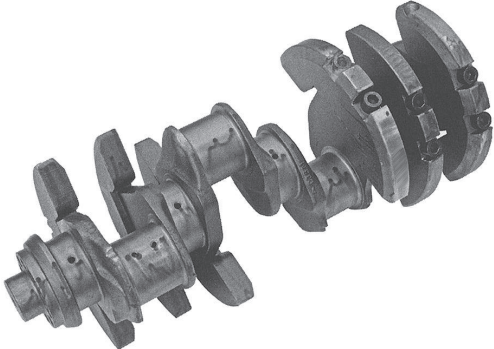

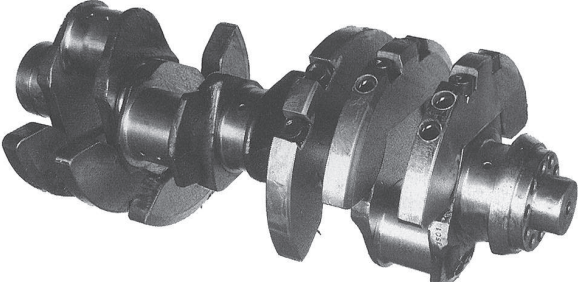
OM 402.901, OM 422 -- motor 470878, OM 422 A/LA	<ul style="list-style-type: none"> EN Crankshaft, without bearings DE Kurbelwelle, ohne Lager FR Vilebrequin, sans coussinets ES Cigüeñal, sin cojinetes PT Virabrequim, sem rolamentos RU Коленвал, без подшипника 		422 030 4401	02.19565
--	---	--	--------------	----------

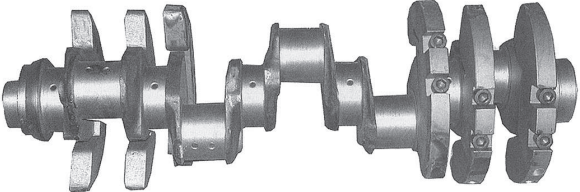

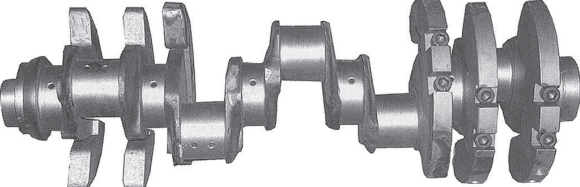
THE ORIGINAL NUMBERS OF THE VEHICLE MANUFACTURER MAY BE USED FOR COMPARISON PURPOSES ONLY AND MUST NOT BE MENTIONED ON INVOICES TO VEHICLE OWNERS.

Application	Description	Details	Ref.	Erqo No.
OM 422 motor 470879 --, OM 442	<ul style="list-style-type: none"> EN Crankshaft, without bearings DE Kurbelwelle, ohne Lager FR Vilebrequin, sans coussinets ES Cigüeñal, sin cojinetes PT Virabrequim, sem rolamentos RU Коленвал, без подшипника 		422 030 4301	02.19564 
OM 442 A + LA	<ul style="list-style-type: none"> EN Crankshaft, without bearings DE Kurbelwelle, ohne Lager FR Vilebrequin, sans coussinets ES Cigüeñal, sin cojinetes PT Virabrequim, sem rolamentos RU Коленвал, без подшипника 		442 030 0801	02.19574 
OM 403	<ul style="list-style-type: none"> EN Crankshaft, without bearings DE Kurbelwelle, ohne Lager FR Vilebrequin, sans coussinets ES Cigüeñal, sin cojinetes PT Virabrequim, sem rolamentos RU Коленвал, без подшипника 		403 030 3001	02.19560 
OM 423 -- motor 493784; OM 423 A/LA	<ul style="list-style-type: none"> EN Crankshaft, without bearings DE Kurbelwelle, ohne Lager FR Vilebrequin, sans coussinets ES Cigüeñal, sin cojinetes PT Virabrequim, sem rolamentos RU Коленвал, без подшипника 		423 030 3401	02.19568 

THE ORIGINAL NUMBERS OF THE VEHICLE MANUFACTURER MAY BE USED FOR COMPARISON PURPOSES ONLY AND MUST NOT BE MENTIONED ON INVOICES TO VEHICLE OWNERS.

1

Application	Description	Details	Ref.	Erqo No.
OM 423 motor 493785 --, OM 443	<ul style="list-style-type: none"> EN Crankshaft, without bearings DE Kurbelwelle, ohne Lager FR Vilebrequin, sans coussinets ES Cigüeñal, sin cojinetes PT Virabrequim, sem engrenagem RU Коленвал, без подшипника 		423 030 3301	02.19567

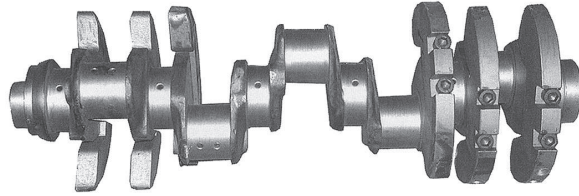

Sample

OM 402 A/LA, OM 422 A/LA, OM 442	<ul style="list-style-type: none"> EN Main bearing kit, STD DE Hauptlagersatz, STD FR Kit de coussinets de palier, STD ES Juego de cojinetes de bancada, STD PT Jogo bronzina mancaí, STD RU Комплект коренных подшипников, ST 		403 030 1340 S1	02.23064
--	--	--	-----------------	----------













OM 402 A/LA, OM 422 A/LA, OM 442	<ul style="list-style-type: none"> EN Main bearing kit, OS 0,25 DE Hauptlagersatz, OS 0,25 FR Kit de coussinets de palier, OS 0,25 ES Juego de cojinetes de bancada, OS 0,25 PT Jogo bronzina mancaí, OS 0,25 RU Комплект коренных подшипников, OS 		403 030 1540 S2	02.23065
--	--	--	-----------------	----------



OM 402 A/LA, OM 422 A/LA, OM 442	<ul style="list-style-type: none"> EN Main bearing kit, OS 0,50 DE Hauptlagersatz, OS 0,50 FR Kit de coussinets de palier, OS 0,50 ES Kit cojinete principal, OS 0,50 PT Jogo bronzina mancaí, OS 0,50 RU Комплект коренных подшипников, OS 		403 030 1640 S	02.23066
--	---	--	----------------	----------

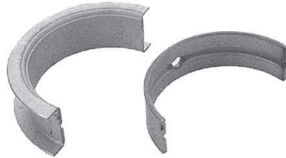







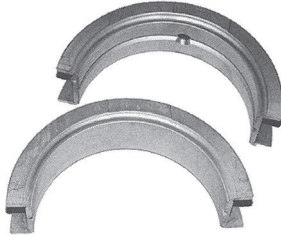

Application	Description	Details	Ref.	Erqo No.
OM 442 A/LA	<ul style="list-style-type: none"> EN Main bearing kit, STD DE Hauptlagersatz, STD FR Kit de coussinets de palier, STD ES Juego de cojinetes de bancada, STD PT Jogo bronzina mancaí, STD RU Комплект коренных подшипников, STD 		442 030 2240 S	02.23067 
OM 401 A/LA, OM 421 A/LA, OM 441 A/LA	<ul style="list-style-type: none"> EN Main bearing kit, OS 0,25 DE Hauptlagersatz, OS 0,25 FR Kit de coussinets de palier, OS 0,25 ES Juego de cojinetes de bancada, OS 0,25 PT Jogo bronzina mancaí, OS 0,25 RU Комплект коренных подшипников, OS 0,25 		403 030 1540 S2	02.23068 
OM 401/402/403 + A/LA, OM 421/422/423 + A/LA, OM 441/443 + A/LA OM 442	<ul style="list-style-type: none"> EN Main bearing kit, STD DE Hauptlagersatz, STD FR Kit de coussinets de palier, STD ES Juego de cojinetes de bancada, STD PT Jogo bronzina mancaí, STD RU Комплект коренных подшипников, STD 		403 030 1340	02.19635 
OM 401/402/403 + A/LA, OM 421/422/423 + A/LA, OM 441/443 + A/LA OM 442	<ul style="list-style-type: none"> EN Main bearing kit, OS 0,25 DE Hauptlagersatz, OS 0,25 FR Kit de coussinets de palier, OS 0,25 ES Juego de cojinetes de bancada, OS 0,25 PT Jogo bronzina mancaí, OS 0,25 RU Комплект коренных подшипников, OS 0,25 		403 030 1540	02.19636 
OM 442 A/LA	<ul style="list-style-type: none"> EN Main bearing kit, STD DE Hauptlagersatz, STD FR Kit de coussinets de palier, STD ES Juego de cojinetes de bancada, STD PT Jogo bronzina mancaí, STD RU Комплект коренных подшипников, STD 		442 030 2240	02.19639 

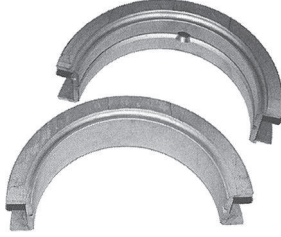
THE ORIGINAL NUMBERS OF THE VEHICLE MANUFACTURER MAY BE USED FOR COMPARISON PURPOSES ONLY AND MUST NOT BE MENTIONED ON INVOICES TO VEHICLE OWNERS.

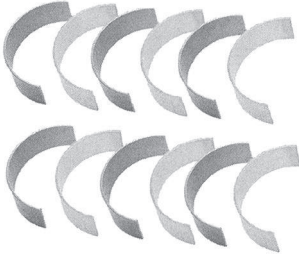

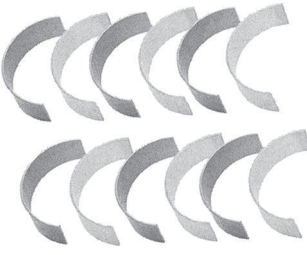



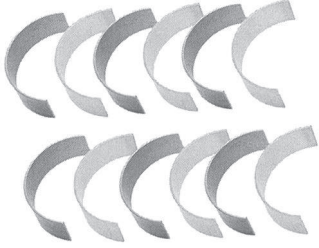

Application	Description	Details	Ref.	Erqo No.
	<ul style="list-style-type: none"> EN Main bearing kit, OS 0,25 DE Hauptlagersatz, OS 0,25 FR Jeu de palier principal, OS 0,25 ES Juego de cojinetes de bancada, OS 0,25 PT Jogo bronzina mancaí, OS 0,25 RU Комплект коренных подшипников, OS 0,25 		442 030 2540	02.19640 
	Sample			
OM 442 A/LA	<ul style="list-style-type: none"> EN Main bearing kit, OS 0,50 DE Hauptlagersatz, OS 0,50 FR Kit de coussinets de palier, OS 0,50 ES Juego de cojinetes de bancada, OS 0,50 PT Jogo bronzina mancaí, OS 0,50 RU Комплект коренных подшипников, OS 0,50 		442 030 2640	02.19641 
	Sample			
OM 442 A/LA	<ul style="list-style-type: none"> EN Main bearing kit, OS 0,50 DE Hauptlagersatz, OS 0,50 FR Kit de coussinets de palier, OS 0,50 ES Juego de cojinetes de bancada, OS 0,50 PT Jogo bronzina mancaí, OS 0,50 RU Комплект коренных подшипников, OS 0,50 		442 030 2640 S	02.23069 
OM 442 A/LA	<ul style="list-style-type: none"> EN Main bearing kit, OS 0,25 DE Hauptlagersatz, OS 0,25 FR Kit de coussinets de palier, OS 0,25 ES Juego de cojinetes de bancada, OS 0,25 PT Jogo bronzina mancaí, OS 0,25 RU Комплект коренных подшипников, OS 0,25 		442 030 2540 S	02.23070 
	Sample			
OM 401/402/403 + A/LA, OM 421/422/423 + A/LA, OM 441/442/443 + A/LA	<ul style="list-style-type: none"> EN Flanged bearing, STD DE Passlagersatz, STD FR Coussinet vilebrequin, STD ES Cojinete de cigüeñal, STD, STD PT Bronzina mancaí, STD RU Комплект упорных подшипников, STD 		422 030 0145	02.19643 

THE ORIGINAL NUMBERS OF THE VEHICLE MANUFACTURER MAY BE USED FOR COMPARISON PURPOSES ONLY AND MUST NOT BE MENTIONED ON INVOICES TO VEHICLE OWNERS.

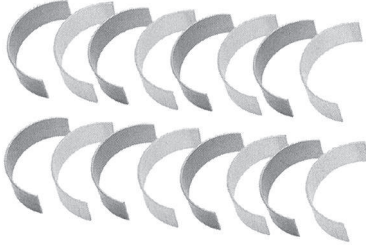
Application	Description	Details	Ref.	Erqo No.
OM 401/402/403 + A/LA, OM 421/422/423 + A/LA, OM 441/442/443 + A/LA	<ul style="list-style-type: none"> EN Flanged bearing, OS 0,25 DE Passlagersatz, OS 0,25 FR Jeu de paliers de réglage, OS 0,25 ES Juego de cojinetes de ajuste, OS 0,25 PT Bronzina mancai, OS 0,25 RU Комплект упорных подшипников, OS 0,25 		422 030 0345	02.19644 
OM 401/402/403 + A/LA, OM 421/422/423 + A/LA, OM 441/442/443 + A/LA	<ul style="list-style-type: none"> EN Flanged bearing, OS 0,50 DE Passlagersatz, OS 0,50 FR Coussinet vilebrequin, OS 0,50 ES Cojinete de cigüeñal, OS 0,50 PT Bronzina mancai, OS 0,50 RU Комплект упорных подшипников, OS 0,50 		422 030 0445	02.19645 
OM 401/421/441 + A/LA	<ul style="list-style-type: none"> EN Con rod bearing kit, STD bearing width 31 mm DE Pleuellagersatz, STD Lagerbreite 31 mm FR Jeu de coussinets de bielle, STD bielle largeur 31 mm ES Juego de cojinetes de biela, STD biela anchura 31 mm PT Jogo bronzina biela, STD largura da bronzina 31 mm RU Комплект шатунных подшипников, STD ширина подшипника 31 мм 		442 030 1560 S1	02.23071 
OM 401 /421 /441 + A/LA	<ul style="list-style-type: none"> EN Con rod bearing kit, OS 0,25 bearing width 31 mm DE Pleuellagersatz, OS 0,25 Lagerbreite 31 mm FR Jeu de coussinets de bielle, OS 0,25 bielle largeur 31 mm ES Juego de cojinetes de biela, OS 0,25 biela anchura 31 mm PT Jogo bronzina biela, OS 0,25 largura da bronzina 31 mm RU Комплект шатунных подшипников, OS 0,25 ширина подшипника 31 мм 		442 030 1160 S1	02.23072 

Sample

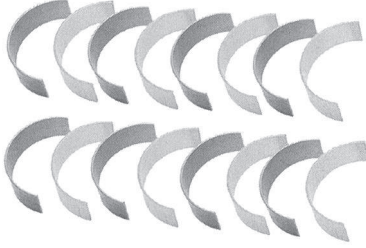
THE ORIGINAL NUMBERS OF THE VEHICLE MANUFACTURER MAY BE USED FOR COMPARISON PURPOSES ONLY AND MUST NOT BE MENTIONED ON INVOICES TO VEHICLE OWNERS.

Application	Description	Details	Ref.	Erqo No.
OM 401 /421 /441 + A/LA	<ul style="list-style-type: none"> EN Con rod bearing kit, OS 0,50 DE Pleuellagersatz, OS 0,50 FR Coussinet de bielle, OS 0,50 ES Kit cojinete biela, OS 0,50 PT Jogo bronzina biela, OS 0,50 RU Комплект шатунных подшипников 		442 030 1260 S	02.23073 
Sample				
OM 402/422/442 + A/LA	<ul style="list-style-type: none"> EN Con rod bearing kit, STD bearing width 31 mm DE Pleuellagersatz, STD Lagerbreite 31 mm FR Jeu de coussinets de bielle, STD bielle largeur 31 mm ES Juego de cojinetes de biela, STD biela anchura 31 mm PT Jogo bronzina biela, STD largura da bronzina 31 mm RU Комплект шатунных подшипников, STD ширина подшипника 31 мм 		442 030 1560 S2	02.23074 
Sample				
OM 402 / 422 / 442 + A/LA	<ul style="list-style-type: none"> EN Con rod bearing kit, OS 0,25 bearing width 31 mm DE Pleuellagersatz, OS 0,25 Lagerbreite 31 mm FR Jeu de coussinets de bielle, OS 0,25 bielle largeur 31 mm ES Juego de cojinetes de biela, OS 0,25 biela anchura 31 mm PT Jogo bronzina biela, OS 0,25 largura da bronzina 31 mm RU Комплект шатунных подшипников, OS 0,25 ширина подшипника 31 мм 		442 030 1160 S2	02.23075 
Sample				
OM 402/422/442 + A/LA	<ul style="list-style-type: none"> EN Con rod bearing kit, OS 0,50 bearing width 31 mm DE Pleuellagersatz, OS 0,50 Lagerbreite 31 mm FR Coussinet de bielle, OS 0,50 bielle largeur 31 mm ES Kit cojinete biela, OS 0,50 biela anchura 31 mm PT Jogo bronzina biela, OS 0,50 largura da bronzina 31 mm RU Комплект шатунных подшипников, OS 0,50 ширина подшипника 31 мм 		422 030 0445 S	02.23076 

THE ORIGINAL NUMBERS OF THE VEHICLE MANUFACTURER MAY BE USED FOR COMPARISON PURPOSES ONLY AND MUST NOT BE MENTIONED ON INVOICES TO VEHICLE OWNERS.

Application	Description	Details	Ref.	Erqo No.
OM 401/402/403 + A/LA, OM 421/422/423 + A/LA, OM 441/442/443 + A/LA	<p>EN Con rod bearing kit, STD bearing width 31 mm</p> <p>DE Pleuellagersatz, STD Lagerbreite 31 mm</p> <p>FR Jeu de coussinets de bielle, STD bielle largeur 31 mm</p> <p>ES Juego de cojinetes de biela, STD biela anchura 31 mm</p> <p>PT Jogo bronzina biela, STD largura da bronzina 31 mm</p> <p>RU Комплект шатунных подшипников, STD ширина подшипника 31 мм</p>		442 030 1560	02.19653 
OM 401/402/403 + A/LA, OM 421/422/423 + A/LA, OM 441/442/443 + A/LA	<p>EN Con rod bearing kit, OS 0,25 bearing width 31 mm</p> <p>DE Pleuellagersatz, OS 0,25 Lagerbreite 31 mm</p> <p>FR Jeu de coussinets de bielle, OS 0,25 bielle largeur 31 mm</p> <p>ES Juego de cojinetes de biela, OS 0,25 biela anchura 31 mm</p> <p>PT Jogo bronzina biela, OS 0,25 largura da bronzina 31 mm</p> <p>RU Комплект шатунных подшипников, OS 0,25 ширина подшипника 31 мм</p>		442 030 1160	02.19651 
OM 401/402/403 + A/LA, OM 421/422/423 + A/LA, OM 441/442/443 + A/LA	<p>EN Con rod bearing kit, OS 0,50 bearing width 31 mm</p> <p>DE Pleuellagersatz, OS 0,50 Lagerbreite 31 mm</p> <p>FR Coussinet de bielle, OS 0,50 bielle largeur 31 mm</p> <p>ES Cojinete biela, OS 0,50 biela anchura 31 mm</p> <p>PT Jogo bronzina biela, OS 0,50 largura da bronzina 31 mm</p> <p>RU Комплект шатунных подшипников, OS 0,50 ширина подшипника 31 мм</p>		442 030 1260	02.19652 







Sample

THE ORIGINAL NUMBERS OF THE VEHICLE MANUFACTURER MAY BE USED FOR COMPARISON PURPOSES ONLY AND MUST NOT BE MENTIONED ON INVOICES TO VEHICLE OWNERS.

Application	Description	Details	Ref.	Erqo No.
OM 401 LA OM 441 A / LA	<p>EN Con rod bearing kit, STD bearing width 26,7 mm</p> <p>DE Pleuellagersatz, STD Lagerbreite 26,7 mm</p> <p>FR Jeu de coussinets de bielle, STD bielle largeur 26,7 mm</p> <p>ES Juego de cojinetes de biela, STD biela anchura 26,7 mm</p> <p>PT Jogo bronzina biela, STD largura da bronzina 26,7 mm</p> <p>RU Комплект шатунных подшипников, STD ширина подшипника 26,7 мм</p>		441 030 2860 S	<p>02.23077</p> 
OM 401 LA OM 441 A / L A	<p>EN Con rod bearing kit, OS 0,25 bearing width 26,7 mm</p> <p>DE Pleuellagersatz, OS 0,25 Lagerbreite 26,7 mm</p> <p>FR Jeu de coussinets de bielle, OS 0,25 bielle largeur 26,7 mm</p> <p>ES Juego de cojinetes de biela, OS 0,25 biela anchura 26,7 mm</p> <p>PT Jogo bronzina biela, OS 0,25 largura da bronzina 26,7 mm</p> <p>RU Комплект шатунных подшипников, OS 0,25 ширина подшипника 26,7 мм</p>		441 030 3060 S	<p>02.23078</p> 
OM 401 LA OM 441 A / LA	<p>EN Con rod bearing kit, OS 0,50 bearing width 26,7 mm</p> <p>DE Pleuellagersatz, OS 0,50 Lagerbreite 26,7 mm</p> <p>FR Jeu de coussinets de bielle, OS 0,50 bielle largeur 26,7 mm</p> <p>ES Juego de cojinetes de biela, OS 0,50 biela anchura 26,7 mm</p> <p>PT Jogo bronzina biela, OS 0,50 largura da bronzina 26,7 mm</p> <p>RU Комплект шатунных подшипников, OS 0,50 ширина подшипника 26,7 мм</p>		441 030 3160 S	<p>02.23079</p> 

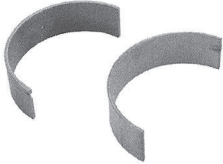
Sample

Sample

Application	Description	Details	Ref.	Erqo No.
OM 401 LA OM 441 A / L A	<p>EN Con rod bearing kit, STD bearing width 26,7 mm</p> <p>DE Pleuellagersatz, STD Lagerbreite 26,7 mm</p> <p>FR Coussinet de bielle, STD bielle largeur 26,7 mm</p> <p>ES Cojinete de biela, STD biela anchura 26,7 mm</p> <p>PT Jogo bronzina biela, STD largura da bronzina 26,7 mm</p> <p>RU Комплект шатунных подшипников, STD ширина подшипника 26,7 мм</p>		441 030 2860	02.19646 
OM 401 LA OM 441 A / LA	<p>EN Con rod bearing kit, OS 0,25 bearing width 26,7 mm</p> <p>DE Pleuellagersatz, OS 0,25 Lagerbreite 26,7 mm</p> <p>FR Jeu de coussinets de bielle, OS 0,25 bielle largeur 26,7 mm</p> <p>ES Juego de cojinetes de biela, OS 0,25 biela anchura 26,7 mm</p> <p>PT Jogo bronzina biela, OS 0,25 largura da bronzina 26,7 mm</p> <p>RU Комплект шатунных подшипников, OS 0,25 ширина подшипника 26,7 мм</p>		441 030 3060	02.19647 
OM 401 LA OM 441 A / LA	<p>EN Con rod bearing kit, OS 0,50 bearing width 26,7 mm</p> <p>DE Pleuellagersatz, OS 0,50 Lagerbreite 26,7 mm</p> <p>FR Jeu de coussinets de bielle, OS 0,50 bielle largeur 26,7 mm</p> <p>ES Juego de cojinetes de biela, OS 0,50 biela anchura 26,7 mm</p> <p>PT Jogo bronzina biela, OS 0,50 largura da bronzina 26,7 mm</p> <p>RU Комплект шатунных подшипников, OS 0,50 ширина подшипника 26,7 мм</p>		441 030 3160	02.19648 
OM 401/421/441 + A/LA, OM 402/422/442 + A/LA, OM 403/423/443 + A/LA	<p>EN Race old version</p> <p>DE Lauftring alte Ausführung</p> <p>FR Fret de joint speed ancienne version</p> <p>ES Anillo de rodadura versión antigua</p> <p>PT Anel pista versão antiga</p> <p>RU Кольцо подшипника старое исполнение</p>		403 031 0727	02.19655 

THE ORIGINAL NUMBERS OF THE VEHICLE MANUFACTURER MAY BE USED FOR COMPARISON PURPOSES ONLY AND MUST NOT BE MENTIONED ON INVOICES TO VEHICLE OWNERS.

1

Application	Description	Details	Ref.	Erqo No.
OM 401/421/441 + A/LA, OM 402/422/442 + A/LA, OM 403/423/443 + A/LA	<p>EN Race new version</p> <p>DE Laufring neue Ausführung</p> <p>FR Fret de joint speed nouvelle version</p> <p>ES Anillo de rodadura nueva versión</p> <p>PT Anel pista dianteiro motor nova versão</p> <p>RU Вращающееся кольцо нового типа</p>		442 031 0027	02.19656 
				
OM 401/421/441 + A/LA, OM 402/422/442 + A/LA, OM 403/423/443 + A/LA	<p>EN Crankshaft screw counterweight at crankshaft</p> <p>DE Kurbelwellenschraube Gegengewicht an Kurbelwelle</p> <p>FR Vis de vilebrequin contrepoids de vilebrequin</p> <p>ES Tornillo del cigüeñal contrapeso cigüeñal</p> <p>PT Parafuso virabrequim contrapeso da cambota</p> <p>RU Болт коленвала противовеса на коленвале</p>	M 16 x 1,5 x 90 mm	442 031 0071	02.19658 
				
OM 423 A/LA, OM 441/442/443 A/LA	<p>EN Crankshaft gear new version - high-grade material</p> <p>DE Kurbelwellenrad neue Ausführung - hochwert. Material</p> <p>FR Roue de vilebrequin nouvelle version - matériau de grande qualité</p> <p>ES Piñón del cigüeñal nueva versión - material de gran valor</p> <p>PT Engrenagem virabrequim nova versão - material de alta qualidade</p> <p>RU Шестерня коленвала нового типа - высококачественный материал</p>		403 050 0403	02.19711 
				

Application	Description	Details	Ref.	Erqo No.
OM 401/402/403 + A/LA, OM 421/422/423 + A/LA, OM 441/442/443 + A/LA	<p>EN Crankshaft gear old Version</p> <p>DE Kurbelwellenrad alte Ausführung</p> <p>FR Roue de vilebrequin ancienne version</p> <p>ES Piñón del cigüeñal versión antigua</p> <p>PT Engrenagem virabrequim versão antiga</p> <p>RU Шестерня коленвала старое исполнение</p>		403 050 0303	02.19710 
OM 401/421/441 + A/LA, OM 402/422/442 + A/LA, OM 403/423/443 + A/LA	<p>EN Oil thrower ring</p> <p>DE Ölverteilterring</p> <p>FR Joint de flasque</p> <p>ES Anillo distribuidor de aceite</p> <p>PT Flange</p> <p>RU Кольцо маслораспределителя</p>		403 031 0332	02.19657 
OM 401/402 LA Euro I, OM 403 motor 154773 --, OM 403/421/422 A/LA, OM 423/443, OM 441/442 A/LA	<p>EN Vibration damper</p> <p>DE Vibrationsdämpfer</p> <p>FR Amortisseur</p> <p>ES Amortiguador de vibraciones</p> <p>PT Amortecedor vibração</p> <p>RU Виброгаситель</p>		442 030 2303	02.19577 
OM 403 -- motor 154772	<p>EN Vibration absorber</p> <p>DE Vibrationsdämpfer</p> <p>FR Amortisseur</p> <p>ES Amortiguador de vibraciones</p> <p>PT Amortecedor vibração</p> <p>RU Виброгаситель</p>		447 035 0300	02.19665 
OM 401/402 LA Euro I, OM403 motor 154773 --, OM 403/421/422 A/LA, OM 423/443, OM 441/442 A/LA	<p>EN Screw</p> <p>DE Schraube</p> <p>FR Vis</p> <p>ES Tornillo</p> <p>PT Parafuso</p> <p>RU Болт</p>	M 8 x 1,5 - 12.9	423 990 0012	02.22461 

THE ORIGINAL NUMBERS OF THE VEHICLE MANUFACTURER MAY BE USED FOR COMPARISON PURPOSES ONLY AND MUST NOT BE MENTIONED ON INVOICES TO VEHICLE OWNERS.

Application	Description	Details	Ref.	Erqo No.
OM 401/402 LA (Euro I) motor 507955--; OM 421/422/423 motor 507955--; OM 441/442 A/LA - motor 713395; OM 443	<ul style="list-style-type: none"> EN Hub DE Nabe FR Moyeu ES Buje PT Cubo RU Ступица 		423 035 0013	02.19672 
OM 443 A/LA	<ul style="list-style-type: none"> EN Hub DE Nabe FR Moyeu ES Buje PT Cubo RU Ступица 		443 035 0113	02.19673 
OM 401/421/441 + A/LA, OM 402/422/442 + A/LA, O M 403/423/443 + A/LA	<ul style="list-style-type: none"> EN Crankshaft screw damper at crankshaft DE Kurbelwellenschraube Dämpfer an Kurbelwelle FR Vis de vilebrequin damper de vilebrequin ES Tornillo del cigüeñal suspension cigüeñal PT Parafuso virabrequin amortecedor vibraões da cambota RU Болт коленвала демпфера к коленвалу 	M 16 x 1,5 	422 035 0071	02.19678 
OM 401/421/441 + A/LA, OM 402/422/442 + A/LA, OM 403/423/443 + A/LA	<ul style="list-style-type: none"> EN Screw DE Schraube FR Vis ES Tornillo PT Parafuso RU Болт 	M 8 x 16 	910105 008008	02.22951 
OM 401/402/403 motor 191534 --; OM 401/402/403 A/LA -- motor 712353; OM 421/422/423 --motor 712353; OM 441/442/443 A/LA --motor 712353	<ul style="list-style-type: none"> EN Pulley, 1 groove DE Riemenscheibe, 1-rillig FR Poulie à courroie, 1 rainure ES Polea de transmisión, 1 estría PT Polia, 1 canal RU Ременный шкив, одноручейный 		443 035 0112	02.19671 

Application	Description	Details	Ref.	Erqo No.
OM 401/402/403 (Euro 0)	<ul style="list-style-type: none"> EN Pulley, 2 grooves DE Riemenscheibe, 2-rillig FR Poulie à courroie, 2 rainures ES Polea de transmisión, 2 estrías PT Polia, 2 canais RU Ременный шкив, двухручейный 		403 035 2112	02.19667 
OM 401/402 LA (Euro I), OM 441/442 A/LA motor 712354 --; OM 443 motor 712354 --	<ul style="list-style-type: none"> EN Pulley, 1 groove DE Riemenscheibe, 1-rillig FR Poulie à courroie, 1 rainure ES Polea de transmisión, 1 estría PT Polia, 1 canal RU Ременный шкив, одноручейный 		442 035 1012	02.19670 
OM 402.919/921 (Euro 0)	<ul style="list-style-type: none"> EN Pulley, 2 grooves DE Riemenscheibe, 2-rillig FR Poulie à courroie, 2 rainures ES Polea de transmisión, 2 pistas PT Polia, 2 canais RU Ременный шкив, двухручейный 		403 035 0812	02.19666 
OM 402.907, OM 403.918, OM 421.908/910/951, OM 422.908/915/917/918, OM 441.908/909/911, OM 441.918/960/961. OM 442.910/911/918, OM 442.919/954/955, OM 442.939	<ul style="list-style-type: none"> EN Pulley, 6 grooves DE Riemenscheibe, 6-rillig FR Poulie à courroie, 6 rainures ES Polea de transmisión, 6 estrías PT Polia, 6 canais RU Ременный шкив, шестиручейный 		403 035 2912	02.19668 

THE ORIGINAL NUMBERS OF THE VEHICLE MANUFACTURER MAY BE USED FOR COMPARISON PURPOSES ONLY AND MUST NOT BE MENTIONED ON INVOICES TO VEHICLE OWNERS.

1

Application	Description	Details	Ref.	Erqo No.
OM 403.933/935; OM 421.905/906/907/908; OM 422.905/907/909; OM 422.912/914/919; OM 422 920/922/923; OM 442.905; OM 442 (440.910/911/948)	<p>EN Intermediate piece</p> <p>DE Lüfternabe</p> <p>FR Moyeu d'aérateur</p> <p>ES Buje del ventilador</p> <p>PT Acoplamento hélice</p> <p>RU Ступица вентилятора</p>	54 mm	403 035 0914	02.19675 

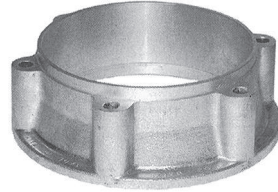

OM 401/402 LA (Euro I) --motor 870302; OM 422/423 + A/LA, OM 441/442 +A/LA -- motor 870302	<p>EN Intermediate piece</p> <p>DE Lüfternabe</p> <p>FR Moyeu d'aérateur</p> <p>ES Buje del ventilador</p> <p>PT Acoplamento hélice</p> <p>RU Ступица вентилятора</p>	85 mm	422 035 1114	02.19676 
--	---	-------	--------------	--

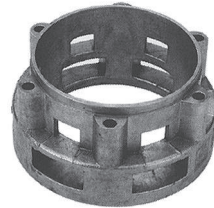

OM 401/402 LA (Euro I) motor 870303 --; OM 441/442 LA motor 870303 --	<p>EN Intermediate piece</p> <p>DE Zwischenstück</p> <p>FR Entretoise</p> <p>ES Pieza intermedia</p> <p>PT União</p> <p>RU Проставка</p>		442 035 0214	02.19677 
---	--	--	--------------	---



Application	Description	Details	Ref.	Erqo No.
OM 402, OM 422.909/923, OM 422 LA (BM 953/955/959)	<ul style="list-style-type: none"> EN Flywheel DE Schwungrad FR Volant moteur ES Volante motor PT Volante motor RU Маховик 	Ø 380 mm	403 030 1305	02.19579 
OM 421 /441 motor 200643 --, motor 491738 --; OM 402 / 422 / 442, OM 403 / 423	<ul style="list-style-type: none"> EN Flywheel DE Schwungrad FR Volant moteur ES Volante motor PT Volante motor RU Маховик 	Ø 420 mm	447 030 1805	02.19586 
OM 401 LA, OM 402 LA, OM 441 A/LA, OM 442 A/LA, OM 443	<ul style="list-style-type: none"> EN Flywheel DE Schwungrad FR Volant moteur ES Volante motor PT Volante motor RU Маховик 	Ø 430 mm	442 030 0205	02.19583 

THE ORIGINAL NUMBERS OF THE VEHICLE MANUFACTURER MAY BE USED FOR COMPARISON PURPOSES ONLY AND MUST NOT BE MENTIONED ON INVOICES TO VEHICLE OWNERS.

1

Application	Description	Details	Ref.	Erqo No.
OM 401 LA, OM 402 LA, OM 441 LA, OM 442 LA	<ul style="list-style-type: none"> EN Flywheel DE Schwungrad FR Volant moteur ES Volante motor 	Ø 430 mm	442 030 1905	02.19585
Euro II	<ul style="list-style-type: none"> PT Volante motor RU Маховик 			

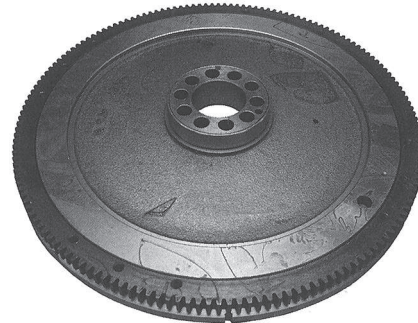





OM 441.951/961 (OM 441 LA)	<ul style="list-style-type: none"> EN Flywheel DE Schwungrad FR Volant moteur ES Volante motor PT Volante motor RU Маховик 	Ø 400 mm	441 030 0405	02.19582
-------------------------------	--	----------	--------------	----------

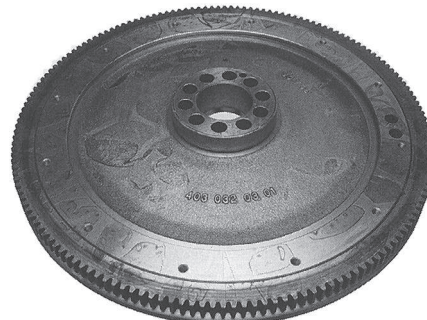

OM 442 A/LA	<ul style="list-style-type: none"> EN Flywheel for vehicles with dual clutch DE Schwungrad für Fahrzeuge mit Doppelkupplung FR Volant moteur pour véhicules avec embrayage double ES Volante motor para vehículos con doble disco embrague PT Volante motor para veículos com embreagem dupla RU Маховик для автомобилей с двойным сцеплением 	Ø 380 mm	422 030 0505	02.19581
-------------	---	----------	--------------	----------











Application	Description	Details	Ref.	Erqo No.
OM 401/421/441 + A/LA, OM 402/422/442 + A/LA, OM 403/423/443 + A/LA	<p>EN Ring gear, 160 teeth</p> <p>DE Zahnring, 160 Zähne</p> <p>FR Couronne de démarrage, 160 dents</p> <p>ES Anillo dentado, 160 dientes</p> <p>PT Cremalheira, 160 dentes</p> <p>RU Зубчатое кольцо, 160 зубья</p>		403 032 0305	02.19659 
OM 401/421/441 + A/LA, OM 402/422/442 + A/LA, OM 403/423/443 + A/LA	<p>EN Ring gear for repair of flywheels with damaged ring gear fit</p> <p>DE Zahnring zur Reparatur von Schwungrädern mit beschädigtem Zahnkranzpassitz</p> <p>FR Couronne de démarrage pour la réparation des volants moteur avec couronne de démarrage endommagée</p> <p>ES Anillo dentado para reparación del volante con corona dentada dañada</p> <p>PT Cremalheira para reparação cremalheira do volante motor</p> <p>RU Зубчатое кольцо для ремонта маховиков с поврежденной посадкой зубчатого венца</p>		403 032 0705	02.19660 
OM 401/421/441 + A/LA, OM 402/422/442 + A/LA, OM 403/423/443 + A/LA	<p>EN Race</p> <p>DE Laufring</p> <p>FR Fret de joint speed</p> <p>ES Anillo de rodadura</p> <p>PT Anel pista</p> <p>RU Вращающееся кольцо</p>		403 032 0309	02.19661 
OM 401 /402/403 + A/LA, OM 421 /422/423 + A/LA, OM 441 /442/443 + A/LA	<p>EN Ball bearing</p> <p>DE Kugellager</p> <p>FR Roulement pilote</p> <p>ES Rodamiento de bolas</p> <p>PT Rolamento</p> <p>RU Шариковый подшипник</p>	repl. FAG 546485	004 981 2125	02.22395 

1









Application	Description	Details	Ref.	Erqo No.
OM 401/421, OM 402/422	<p>EN Spacer ring for old version of ball bearing</p> <p>DE Abstandring für alte Ausführung des Kugellagers</p> <p>FR Entretoise pour ancienne version de roulement pilote</p> <p>ES Anillo distanciador para cojinete versión antigua</p> <p>PT Espaçador do volante do motor para versão antiga da rolamento</p> <p>RU Распорное кольцо, для старой версии подшипника 4.61241</p>		403 032 0151	<p>02.19662</p> 
OM 401/421/441 + A/LA, OM 402/422/442 + A/LA, OM 403/423/443 + A/LA	<p>EN Screw flywheel at crankcase</p> <p>DE Schraube Schwungrad an Kurbelwelle</p> <p>FR Vis de volant moteur volant moteur sur vilebrequin</p> <p>ES Tornillo volante en el cigüeñal</p> <p>PT Parafuso fixar volante motor á cambota</p> <p>RU Болт маховика к коленвалу</p>	M 16 x 1,5 - 10.9 mm	422 032 0271	<p>02.19663</p> 

Connecting RodPleuelstange • Bielle • Biela
Biela • Шатун

Application	Description	Details	Ref.	Erqo No.
OM 402/422/442 + A/LA, OM 403/423/443 + A/LA	<ul style="list-style-type: none"> EN Connecting rod, straight head DE Pleuelstange, gerader Kopf FR Bielle, tête droite ES Biela, cabeza recta PT Biela, cabeça reta RU Шатун, прямая головка 		442 030 0420	02.23080 
OM 402/422/442 + A/LA, OM 403/423/443 + A/LA	<ul style="list-style-type: none"> EN Connecting rod, conical head DE Pleuelstange, konischer Kopf FR Bielle, tête conique ES Biela, cabeza cónica PT Biela, cabeça cónica RU Шатун, коническая головка 		442 030 0220	02.23081 
OM 401 LA, OM 441 + A/LA	<ul style="list-style-type: none"> EN Connecting rod DE Pleuelstange FR Bielle ES Biela PT Biela RU Шатун 		441 030 0820	02.23082 
OM 401/402/403 + A/LA, OM 421/422/423 + A/LA, OM 441/442	<ul style="list-style-type: none"> EN Con rod bushing, old version DE Pleuelbuchse, alte Ausführung FR Douille de bielle, vieille version ES Casquillo de biela, versión antigua PT Bucha biela, versão antiga RU Втулка нижней головки шатуна старая версия 		403 038 0050	02.23083 

THE ORIGINAL NUMBERS OF THE VEHICLE MANUFACTURER MAY BE USED FOR COMPARISON PURPOSES ONLY AND MUST NOT BE MENTIONED ON INVOICES TO VEHICLE OWNERS.

1

Application	Description	Details	Ref.	Erqo No.
OM 401/402/403 + A/LA, OM 421/422/423 + A/LA, OM 441/442/443 + A/LA	<ul style="list-style-type: none"> EN Con rod bushing, semi DE Pleuelbuchse, semi FR Douille de bielle, semi ES Casquillo de biela, semi PT Vucha biela, semi RU Втулка нижней головки шатуна 		442 038 0150	02.19683 
OM 401/402/403 + A/LA, OM 421/422/423 + A/LA, OM 441/442/443 + A/LA	<ul style="list-style-type: none"> EN Con rod bushing, semi DE Pleuelbuchse, semi FR Douille de bielle, semi ES Casquillo de biela, semi PT Vucha biela, semi RU Втулка шатуна 		403 038 0450	02.19681 
OM 401/402/403, (- motor 070546)	<ul style="list-style-type: none"> EN Con rod bushing, semi DE Pleuelbuchse, semi FR Douille de bielle, semi ES Casquillo de biela, semi PT Vucha biela, semi RU Втулка шатуна 		403 038 0250	02.19680 
OM 401/421/441 + A/LA, OM 402/422/442 + A/LA, OM 403/423/443 + A/LA	<ul style="list-style-type: none"> EN Screw, connecting rod old version DE Pleuelschraube alte Ausführung FR Boulon de bielle ancienne version ES Tornillo de biela predecesor PT Parafuso, biela versão antiga RU Шатунный болт старая версия 		403 038 0271	02.19684 

THE ORIGINAL NUMBERS OF THE VEHICLE MANUFACTURER MAY BE USED FOR COMPARISON PURPOSES ONLY AND MUST NOT BE MENTIONED ON INVOICES TO VEHICLE OWNERS.

Connecting RodPleuelstange • Bielle • Biela
Biela • Шатун

Application	Description	Details	Ref.	Erqo No.
OM 401/421/441 + A/LA,	EN Connecting rod screw		442 038 0071	02.19685
OM 402/422/442 + A/LA,	DE Pleuelschraube			
OM 403/423/443 + A/LA,	FR Boulon de bielle			
	ES Tornillo de biela			
	PT Parafuso, biela			
OM 403/423/443 + A/LA	RU Шатунный болт			



1

Application	Description	Details	Ref.	Erqo No.
OM 401/402/403 Euro 0	<ul style="list-style-type: none"> EN Piston with liner DE Kolben mit Laufbuchse FR Piston et chemise ES Pistón con camisa PT Pistão e camisa RU Поршень с гильзой цилиндра 	repl. Mahle 003 45 93	403 030 1637	02.19615



OM 441 LA (BM 445); OM 442 LA (BM 446)	<ul style="list-style-type: none"> EN Piston with liner DE Kolben mit Laufbuchse FR Piston et chemise ES Pistón con camisa PT Pistão e camisa RU Поршень с гильзой цилиндра 	repl. Mahle 003 90 90	442 030 3037	02.19632
---	---	-----------------------	--------------	----------



Sample

OM 401 LA (Euro I), OM 402 LA (Euro I)	<ul style="list-style-type: none"> EN Piston with liner DE Kolben mit Laufbuchse FR Piston et chemise ES Pistón con camisa PT Pistão e camisa RU Поршень с гильзой цилиндра 	repl. Mahle 003 62 90	402 030 0437	02.19614
---	---	-----------------------	--------------	----------

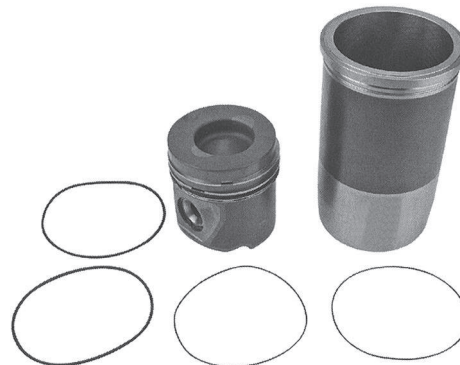

Application	Description	Details	Ref.	Erqo No.
OM 441/442/443 A/LA --motor 622823	EN Piston with liner DE Kolben mit Lauffbuchse FR Piston et chemise ES Pistón con camisa PT Pistão e camisa RU Поршень с гильзой цилиндра	repl. Mahle 003 76 93	442 030 0437	02.19624



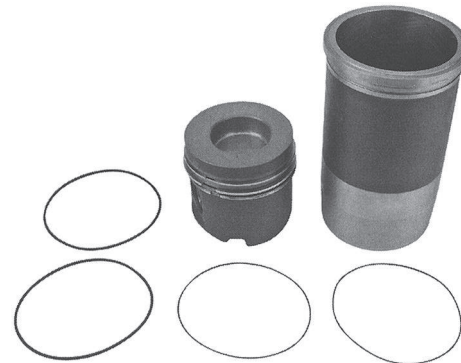

1

OM 421/422/423 A/LA	EN Piston with liner DE Kolben mit Lauffbuchse FR Piston et chemise ES Pistón con camisa PT Pistão e camisa RU Поршень с гильзой цилиндра	repl. Mahle 003 67 95	422 030 0237	02.19617
------------------------	--	-----------------------	--------------	----------







OM 421/422/423 -- motor 535118	EN Piston with liner DE Kolben mit Lauffbuchse FR Piston et chemise ES Pistón con camisa PT Pistão e camisa RU Поршень с гильзой цилиндра	repl. Mahle 003 66 93	423 030 1037	02.19621
-----------------------------------	--	-----------------------	--------------	----------



Application	Description	Details	Ref.	Erqo No.
OM 421/422/423 motor 535119 --	<ul style="list-style-type: none"> EN Piston with liner DE Kolben mit Lauffbuchse FR Piston et chemise ES Pistón con camisa PT Pistão e camisa RU Поршень с гильзой цилиндра 	repl. Mahle 003 66 80	423 030 0937	02.19620 
Sample				
OM 441/442/443 A/LA motor 622824 --	<ul style="list-style-type: none"> EN Piston with liner DE Kolben mit Lauffbuchse FR Piston et chemise ES Pistón con camisa PT Pistão e camisa RU Поршень с гильзой цилиндра 	repl. Mahle 003 91 90	442 030 1337	02.19626 
Sample				
OM 442.977/978, OM 442 (BM 440.940/941/942/945)	<ul style="list-style-type: none"> EN Piston with liner DE Kolben mit Lauffbuchse FR Piston et chemise ES Pistón con camisa PT Pistão e camisa RU Поршень с гильзой цилиндра 	repl. Mahle 003 92 90	442 030 2737	02.19631 
Sample				

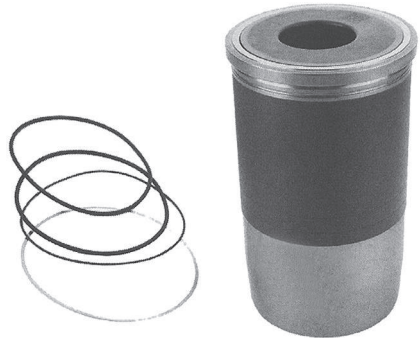







THE ORIGINAL NUMBERS OF THE VEHICLE MANUFACTURER MAY BE USED FOR COMPARISON PURPOSES ONLY AND MUST NOT BE MENTIONED ON INVOICES TO VEHICLE OWNERS.

Application	Description	Details	Ref.	Erqo No.
OM 441 LA (BM 989-999), OM 442 A/LA (BM 440.9**)	<ul style="list-style-type: none"> EN Piston with liner DE Kolben mit Laubuchse FR Piston et chemise ES Pistón con camisa PT Pistão e camisa RU Поршень с гильзой цилиндра 		442 030 3137	02.19633 
				
OM 441, OM 442, OM 443	<ul style="list-style-type: none"> EN Piston with liner DE Kolben mit Laubuchse FR Piston et chemise ES Pistón con camisa PT Pistão e camisa RU Поршень с гильзой цилиндра 	repl. Mahle 003 78 90	442 030 0137	02.19623 
				
OM 401/402/403	<ul style="list-style-type: none"> EN Cylinder liner DE Zylinderlaufbuchse FR Chemise de cylindre ES Camisa de cilindro PT Camisa motor RU Гильза цилиндра 	repl. Mahle 003 WN 14 / Ø 125 mm	403 011 2510	02.19471 
				

1

Application	Description	Details	Ref.	Erqo No.
OM 421/422/423 + A/LA, OM 441/442/443 + A/LA	<ul style="list-style-type: none"> EN Cylinder liner DE Zylinderlaufbuchse FR Chemise de cylindre ES Camisa de cilindro PT Camisa motor RU Гильза цилиндра 	repl. Mahle 003 WN 25 / Ø 128 mm	444 011 0210	02.19479 
				
OM 401/402/403	<ul style="list-style-type: none"> EN Cylinder liner DE Zylinderlaufbuchse FR Chemise de cylindre ES Camisa de cilindro PT Camisa motor RU Гильза цилиндра 	repl. Mahle 003 WN 24 / Ø 125 mm	403 011 3410	02.19472 
				
OM 421/422/423 + A/LA, OM 441/442/443 + A/LA	<ul style="list-style-type: none"> EN Cylinder liner old version DE Zylinderlaufbuchse alte Ausführung FR Chemise de cylindre ancienne version ES Camisa de cilindro versión antigua PT Camisa motor versão antiga da RU Гильза цилиндра старая версия 	repl. Mahle 003 WN 15 / Ø 128 mm	422 011 0310	02.19473 
				

THE ORIGINAL NUMBERS OF THE VEHICLE MANUFACTURER MAY BE USED FOR COMPARISON PURPOSES ONLY AND MUST NOT BE MENTIONED ON INVOICES TO VEHICLE OWNERS.

Application	Description	Details	Ref.	Erqo No.
OM 441, OM 442, OM 443	<ul style="list-style-type: none"> EN Cylinder liner DE Zylinderlaufbuchse FR Chemise de cylindre ES Camisa de cilindro PT Camisa motor RU Гильза цилиндра 	repl. Mahle 003 WN 23 / Ø130 mm	442 011 0310	02.19476 
				
OM 401/402/403	<ul style="list-style-type: none"> EN Piston DE Kolben FR Piston ES Pistón PT Pistão RU Поршень 	repl. Mahle 003 45 00 / Ø 125 mm	403 030 4917	02.19589 
				
OM 401 LA, OM 402 LA	<ul style="list-style-type: none"> EN Piston DE Kolben FR Piston ES Pistón PT Pistão RU Поршень 	repl. Mahle 003 62 00 / Ø 125 mm	402 030 0617	02.19587 
				
				Sample
OM 421/422/423 A/LA	<ul style="list-style-type: none"> EN Piston DE Kolben FR Piston ES Pistón PT Pistão RU Поршень 	repl. Mahle 003 67 00 / Ø 128 mm	422 030 0617	02.19590 
				
				Sample

THE ORIGINAL NUMBERS OF THE VEHICLE MANUFACTURER MAY BE USED FOR COMPARISON PURPOSES ONLY AND MUST NOT BE MENTIONED ON INVOICES TO VEHICLE OWNERS.

1

Application	Description	Details	Ref.	Erqo No.
OM 421/422/423 motor 007893 -- -- motor 470879	<ul style="list-style-type: none"> EN Piston DE Kolben FR Piston ES Pistón PT Pistão RU Поршень 	repl. Mahle 003 66 10 / Ø 128 mm	423 030 1817	02.19592



Sample

OM 421/422/423 A	<ul style="list-style-type: none"> EN Piston DE Kolben FR Piston ES Pistón PT Pistão RU Поршень 	Ø 128 mm	422 030 0237	02.23084
------------------	---	----------	--------------	----------



Sample

OM 421/422/423 -- motor 007892, motor 470879 --	<ul style="list-style-type: none"> EN Piston DE Kolben FR Piston ES Pistón PT Pistão RU Поршень 	repl. Mahle 003 66 10 / Ø 128 mm	423 030 0617	02.19591
---	---	----------------------------------	--------------	----------







OM 441/442/443 A/LA motor 622824 --	<ul style="list-style-type: none"> EN Piston DE Kolben FR Piston ES Pistón PT Pistão RU Поршень 	repl. Mahle 003 91 00 / Ø 128 mm	442 030 3217	02.19596
---	---	----------------------------------	--------------	----------











Sample

THE ORIGINAL NUMBERS OF THE VEHICLE MANUFACTURER MAY BE USED FOR COMPARISON PURPOSES ONLY AND MUST NOT BE MENTIONED ON INVOICES TO VEHICLE OWNERS.



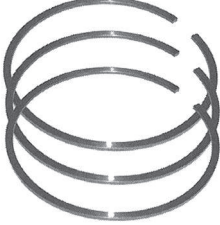

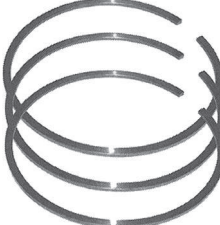
Application	Description	Details	Ref.	Erqo No.
OM 441/442/443 A/LA --motor 622823	EN Piston DE Kolben FR Piston ES Pistón PT Pistão RU Поршень	repl. Mahle 003 76 00 / Ø 128 mm	442 030 0717	02.19593 
Sample				
OM 441 LA (BM 445); OM 442 LA (BM 446)	EN Piston DE Kolben FR Piston ES Pistón PT Pistão RU Поршень	repl. Mahle 003 90 00 / Ø 128 mm	442 030 3117	02.19595 
Sample				
OM 442.977/978, OM 442 (BM 440.940/941/942/945)	EN Piston DE Kolben FR Piston ES Pistón PT Pistão RU Поршень	repl. Mahle 003 92 00 / Ø 128 mm	442 030 3617	02.19598 
OM 441 LA (BM 989-999), OM 442 A/LA (BM 440.9**)	EN Piston DE Kolben FR Piston ES Pistón PT Pistão RU Поршень	repl. Mahle 003 93 00 / Ø 128 mm	442 030 3517	02.19597 

THE ORIGINAL NUMBERS OF THE VEHICLE MANUFACTURER MAY BE USED FOR COMPARISON PURPOSES ONLY AND MUST NOT BE MENTIONED ON INVOICES TO VEHICLE OWNERS.

1

Application	Description	Details	Ref.	Erqo No.
OM 441, OM 442, OM 443	<ul style="list-style-type: none"> EN Piston DE Kolben FR Piston ES Pistón PT Pistão RU Поршень 	repl. Mahle 003 78 00 / Ø 130 mm	444 030 0417	02.19599 
				
OM 401/402/403	<ul style="list-style-type: none"> EN Piston ring kit DE Kolbenringsatz FR Jeu de segments ES Juego de segmentos de pistón PT Jogo anel pistão RU Комплект поршневых колец 	repl. Mahle 003 45 N0 / Ø 125 mm	402 030 0024	02.19608 
				
OM 421/422/423	<ul style="list-style-type: none"> EN Piston ring kit DE Kolbenringsatz FR Jeu de segments ES Juego de segmentos de pistón PT Jogo anel pistão RU Комплект поршневых колец 	repl. Mahle 003 76 N0 / Ø 128 mm	423 030 0224	02.19612 
				
OM 421/422/423 A+LA, OM 441/442/443 A+LA	<ul style="list-style-type: none"> EN Piston ring kit DE Kolbenringsatz FR Jeu de segments ES Juego de segmentos de pistón PT Jogo anel pistão RU Комплект поршневых колец 	repl. Mahle 003 76 N0 / Ø 128 mm	422 030 0124	02.19610 
				
OM 401 LA, OM 402 LA	<ul style="list-style-type: none"> EN Piston ring kit DE Kolbenringsatz FR Jeu de segments ES Juego de segmentos de pistón PT Jogo anel pistão RU Комплект поршневых колец 	repl. Mahle 003 62 N0 / Ø 125 mm	402 030 0124	02.19609 
				

THE ORIGINAL NUMBERS OF THE VEHICLE MANUFACTURER MAY BE USED FOR COMPARISON PURPOSES ONLY AND MUST NOT BE MENTIONED ON INVOICES TO VEHICLE OWNERS.

Application	Description	Details	Ref.	Erqo No.
OM 441 Euro I, OM 442 Euro I, OM 443 Euro I, OM 444 Euro I	<ul style="list-style-type: none"> EN Piston ring kit DE Kolbenringsatz FR Jeu de segments ES Juego de segmentos de pistón PT Jogo anel pistão RU Комплект поршневых колец 	repl. Mahle 003 78 N0 / Ø 130 mm	442 030 0024	02.19613 
OM 421 + A + LA; OM 422 + A + LA; OM 423 + A + LA; OM 441 + A + LA; OM 442 + A + LA; OM 443 + A + LA	<ul style="list-style-type: none"> EN Seal ring kit, green DE Dichtringsatz, grün FR Jeu de bagues d'étanchéité, vert ES Juego de retenes, verde PT Jogo anel camisa, verde RU Комплект уплотнительных колец, зеленый 		015 997 9148 S1	02.23085 
OM401, OM 402, OM403	<ul style="list-style-type: none"> EN Seal ring kit, black DE Dichtringsatz, schwarz FR Jeu de bagues d'étanchéité, noir ES Juego de retenes, negro PT Jogo anel camisa, preto RU Комплект уплотнительных колец, черные 	402/403-125-3 PCS.	025 997 8348 S1	02.23086 
OM401,OM 402, OM403	<ul style="list-style-type: none"> EN Seal ring kit, green DE Dichtringsatz, grün FR Jeu de bagues d'étanchéité, vert ES Juego de retenes, verde PT Jogo anel camisa, verde RU Комплект уплотнительных колец, зеленая 	402/403-125-3 PCS.	012 997 7148 S1	02.23087 
OM401.OM 402, OM403	<ul style="list-style-type: none"> EN Seal ring kit, black DE Dichtringsatz, schwarz FR Jeu de bagues d'étanchéité, noir ES Juego de retenes, negro PT Jogo anel camisa, preto RU Комплект уплотнительных колец, черная 	402/403-125-4 PCS.	025 997 8348 S2	02.23088 

THE ORIGINAL NUMBERS OF THE VEHICLE MANUFACTURER MAY BE USED FOR COMPARISON PURPOSES ONLY AND MUST NOT BE MENTIONED ON INVOICES TO VEHICLE OWNERS.

1

Application	Description	Details	Ref.	Erqo No.
OM 401, OM 402, OM 403	<ul style="list-style-type: none"> EN Seal ring kit, green DE Dichtringsatz, grün FR Jeu de bagues d'étanchéité, vert ES Juego de anillos de obturación, verde PT Jogo anel vedação, verde RU Комплект уплотнительных колец, зеленый 	402/403-125-4 PCS.	015 997 9148 S3	02.23089 

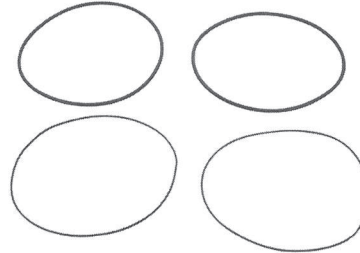

OM 421 + A + LA, OM 422 + A + LA, OM 423 + A + LA, OM 441 + A + LA, OM 442 + A + LA, OM 443 + A + LA	<ul style="list-style-type: none"> EN Seal ring kit, green DE Dichtringsatz, grün FR Jeu de bagues d'étanchéité, vert ES Juego de retenes, verde PT Jogo anel camisa, verde RU Комплект уплотнительных колец, зеленый 	422/423-128-3 PCS.	015 997 9148 S2	02.23090 
---	---	--------------------	-----------------	--

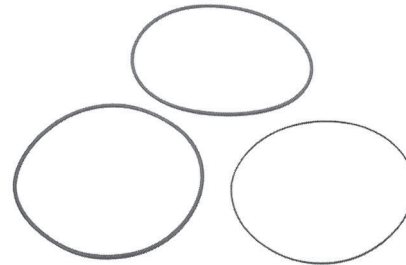



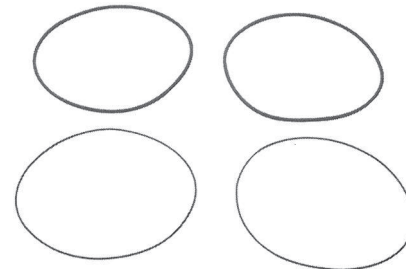

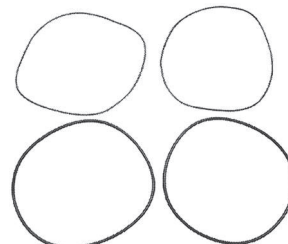

OM 421 + A + LA, OM 422 + A + LA, OM 423 + A + LA, OM 441 + A + LA, OM 442 + A + LA, OM 443 + A + LA	<ul style="list-style-type: none"> EN Seal ring kit, green DE Dichtringsatz, grün FR Jeu de bagues d'étanchéité, vert ES Juego de retenes, verde PT Jogo anel camisa, verde RU Комплект уплотнительных колец, зеленый 	422/423-128-4 PCS.	015 997 9148 S4	02.23091 
---	---	--------------------	-----------------	--

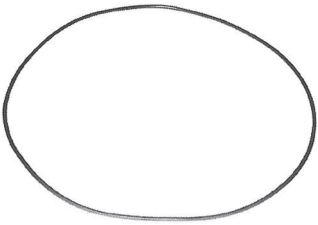

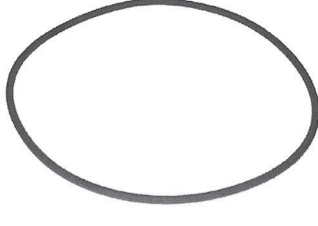

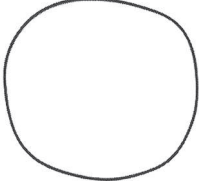
OM 421 + A + L A , OM 422 + A + LA, OM 423 + A + L A , OM 441 + A + LA, OM 442 + A + LA, OM 443 + A + LA	<ul style="list-style-type: none"> EN Seal ring kit, black DE Dichtringsatz, schwarz FR Jeu de bagues d'étanchéité, noir ES Juego de retenes, negro PT Jogo anel camisa, preto RU Комплект уплотнительных колец, черная 	422/423-128-4 PCS.	025 997 8348 S3	02.23092 
---	---	--------------------	-----------------	--

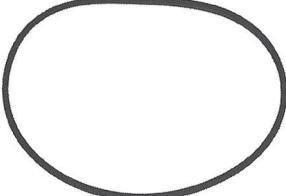







Application	Description	Details	Ref.	Erqo No.
OM 401/421/441 + A/LA, OM 402/422/442 + A/LA, OM 403/423/443 + A/LA	EN O-ring green DE O-Ring grün FR Joint torique vert ES Junta tórica verde PT Anel verde RU Уплотнительное кольцо зеленый	140 x 1,90 mm	015 997 9048	02.22720 
				
OM 401/421/441 + A/LA, OM 402/422/442 + A/LA, OM 403/423/443 + A/LA	EN O-ring green DE O-Ring grün FR Joint torique vert ES Junta tórica verde PT Anel verde RU Уплотнительное кольцо зеленый	144 x 3,8 mm	015 997 9148	02.22721 
				
OM 401/421/441 + A/LA, OM 402/422/442 + A/LA, OM 403/423/443 + A/LA motor --	EN O-ring black DE O-Ring schwarz FR Joint torique noir ES Junta tórica negro PT Anel preto RU Уплотнительное кольцо черные	139,5 x 1,9 mm	025 997 8448	02.22733 
				
OM 401/421/441 + A/LA, OM 402/422/442 + A/LA, OM 403/423/443 + A/LA motor --	EN O-ring black DE O-Ring schwarz FR Joint torique noir ES Junta tórica negro PT Anel preto RU Уплотнительное кольцо черные	143,5 x 3,75 mm	025 997 8548	02.22734 
				

THE ORIGINAL NUMBERS OF THE VEHICLE MANUFACTURER MAY BE USED FOR COMPARISON PURPOSES ONLY AND MUST NOT BE MENTIONED ON INVOICES TO VEHICLE OWNERS.

Application	Description	Details	Ref.	Erqo No.
OM 401/402/403	<ul style="list-style-type: none"> EN O-ring black DE O-Ring schwarz FR Joint torique noir ES Junta tórica negro PT Anel preto RU Уплотнительное кольцо черные 	138,0 x 1,9 mm	009 997 8848	02.22713 
				
OM 401/402/403	<ul style="list-style-type: none"> EN O-ring black DE O-Ring schwarz FR Joint torique noir ES Junta tórica negro PT Anel preto RU Уплотнительное кольцо черные 	140,0 x 3,8 mm	025 997 8348	02.22732 
				
OM 401/421/441 + A/LA, OM 402/422/442 + A/LA, OM 403/423/443 + A/LA	<ul style="list-style-type: none"> EN Seal ring, Tombak DE Dichtring, Tombak FR Joint, Tombak ES Retén, Tombak PT Anel vedação, Tombak RU Уплотнительное кольцо, Томпак 		442 011 0059	02.19483 
				
OM 401/421/441 + A/LA, OM 402/422/442 + A/LA, OM 403/423/443 + A/LA	<ul style="list-style-type: none"> EN Shim DE Ausgleichscheibe FR Cale ES Arandela de ajuste PT Calço RU Компенсационная шайба 	0,5 mm	442 011 0259	02.19484 
				

Application	Description	Details	Ref.	Erqo No.
OM 401/421/441 + A/LA, OM 402/422/442 + A/LA, OM 403/423/443 + A/LA	EN Shim DE Ausgleichscheibe FR Cale ES Arandela de ajuste PT Calço RU Компенсационная шайба	0,8 mm	423 011 0284	02.19491 
OM 401/421/441 + A/LA, OM 402/422/442 + A/LA, OM 403/423/443 + A/LA	EN Shim DE Ausgleichscheibe FR Cale ES Arandela de ajuste PT Calço RU Компенсационная шайба	1,0 mm	442 011 0384	02.19493 
OM 401/421/441 + A/LA, OM 402/422/442 + A/LA, OM 403/423/443 + A/LA	EN Shim DE Ausgleichscheibe FR Cale ES Arandela de ajuste PT Calço RU Компенсационная шайба	1,5 mm	442 011 0184	02.19492 

Application	Description	Details	Ref.	Erqo No.
OM 401	<ul style="list-style-type: none"> EN Camshaft DE Nockenwelle FR Arbre à cames ES Árbol de levas PT Comando válvula RU Распределительный вал 		401 050 1801	02.19687 
Sample				
OM 401 LA, OM 441 LA	<ul style="list-style-type: none"> EN Camshaft DE Nockenwelle FR Arbre à cames ES Árbol de levas PT Comando válvula RU Распределительный вал 		441 050 1701	02.19708 
OM 402	<ul style="list-style-type: none"> EN Camshaft DE Nockenwelle FR Arbre à cames ES Árbol de levas PT Comando válvula RU Распределительный вал 		402 050 1801	02.19690 

Application	Description	Details	Ref.	Erqo No.
OM 402 LA, OM 442 A+LA	<ul style="list-style-type: none"> EN Camshaft DE Nockenwelle FR Arbre à cames ES Árbol de levas PT Comando válvula RU Распределительный вал 		442 050 1701	02.19709 
OM 403	<ul style="list-style-type: none"> EN Camshaft DE Nockenwelle FR Arbre à cames ES Árbol de levas PT Comando válvula RU Распределительный вал 		403 050 4001	02.19695 
OM 421, OM 441 -- motor 519685	<ul style="list-style-type: none"> EN Camshaft DE Nockenwelle FR Arbre à cames ES Árbol de levas PT Comando válvula RU Распределительный вал 		421 050 1401	02.19696 

Sample

Sample

Application	Description	Details	Ref.	Erqo No.
OM 441 motor 519686 --	<ul style="list-style-type: none"> EN Camshaft DE Nockenwelle FR Arbre à cames ES Àrbol de levas PT Comando válvula RU Распределительный вал 		441 050 0601	02.19706 
Sample				
OM 422, OM 442	<ul style="list-style-type: none"> EN Camshaft DE Nockenwelle FR Arbre à cames ES Àrbol de levas PT Comando válvula RU Распределительный вал 		422 050 2101	02.19701 
OM 422 A+LA, OM 442 A+LA	<ul style="list-style-type: none"> EN Camshaft DE Nockenwelle FR Arbre à cames ES Àrbol de levas PT Comando válvula RU Распределительный вал 		422 050 2201	02.19702 







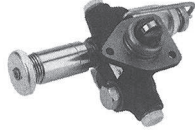

Application	Description	Details	Ref.	Erqo No.
OM 423 A + LA	<ul style="list-style-type: none"> EN Camshaft DE Nockenwelle FR Arbre à cames ES Árbol de levas PT Comando válvula RU Распределительный вал 		423 050 1401	02.19703 
				Sample
OM 441 A + LA	<ul style="list-style-type: none"> EN Camshaft DE Nockenwelle FR Arbre à cames ES Árbol de levas PT Comando válvula RU Распределительный вал 		441 050 0001	02.19704 
				Sample
OM 441 A+LA (BM 441.901, BM 445)	<ul style="list-style-type: none"> EN Camshaft DE Nockenwelle FR Arbre à cames ES Árbol de levas PT Comando válvula RU Распределительный вал 		441 050 1601	02.19707 
				Sample
OM 401/402/403, OM 421/422/423, OM 441/442/443 -- motor 803272	<ul style="list-style-type: none"> EN Valve tappet DE Ventilstößel FR Poussoir de soupape ES Levantaválvulas PT Tucho válvula RU Толкатель клапана 		403 054 1801	02.19760 

1



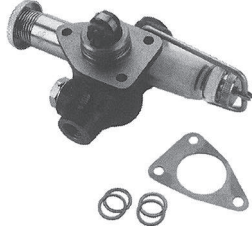

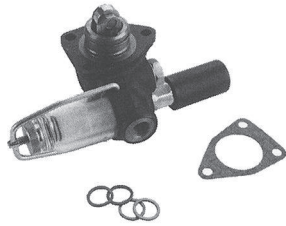

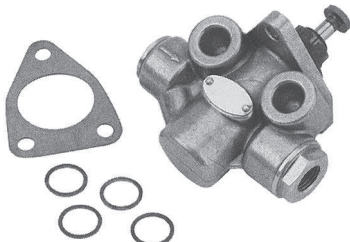



Application	Description	Details	Ref.	Erqo No.
OM 401/421/441 + A/LA, OM 402/422/442 + A/LA, OM 403/423/443 + A/LA motor 803274 --	<p>EN Valve tappet</p> <p>DE Ventilstößel</p> <p>FR Poussoir de soupape</p> <p>ES Levantaválvulas</p> <p>PT "Pucho válvula</p> <p>RU Толкатель клапана</p>		476 050 0025	02.19715 
OM 401/421/441 + A/LA, OM 402/422/442 + A/LA, OM 403/423/443 + A/LA	<p>EN Push rod</p> <p>DE Stößelstange</p> <p>FR Tige du culbuteur</p> <p>ES Empujador</p> <p>PT Vareta válvula</p> <p>RU Штанга толкателя</p>		422 054 0105	02.19762 

Injection Pump

Einspritzpumpe • Pompe à injection • Bomba de alimentación
Bomba inyectara • Впрыскивающий насос









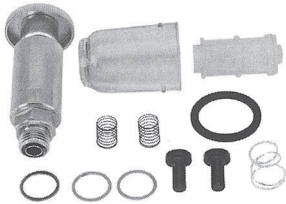

Application	Description	Details	Ref.	Erqo No.
OM 401, OM 402 motor 001178--, OM 403 motor 008525--	EN Fuel feed pump DE Förderpumpe FR Pompe d'alimentation carburant ES Bomba de alimentación PT Bomba combustível RU Подкачивающий насос	repl. Bosch: 0 440 008 997	000 090 0650	02.19860 
				
OM 402 --motor 001177, OM 403 --motor 008524	EN Fuel feed pump DE Förderpumpe FR Pompe d'alimentation carburant ES Bomba de alimentación PT Bomba combustível RU Подкачивающий насос	repl. Bosch: 0 440 008 998	000 090 0550	02.19859 
				
OM 421 + A + LA, OM 422 + A + LA, OM 423 + A + LA, OM 441 + A + LA, OM 442, OM 443	EN Fuel feed pump DE Förderpumpe FR Pompe d'alimentation carburant ES Bomba de alimentación PT Bomba combustível RU Подкачивающий насос	repl. Bosch: 0 440 008 994	000 090 2150	02.19861 
				
OM 423 LA	EN Feed pump DE Förderpumpe FR Pompe d'alimentation carburant ES Bomba de alimentación PT Bomba alimentação RU Подкачивающий насос	repl. Bosch: 0 440 008 990	000 090 3050	02.19862 
				
OM 401 LA Euro I, OM 402 LA Euro I, OM 441 A + LA, OM 441 LA Euro II, OM 442 A + LA, OM 442 LA Euro II, OM 443 A + LA	EN Feed pump DE Förderpumpe FR Pompe d'alimentation ES Bomba de alimentación PT Bomba alimentação RU Подкачивающий насос	repl. Bosch: 0 440 008 989	000 090 3150	02.19863 
				

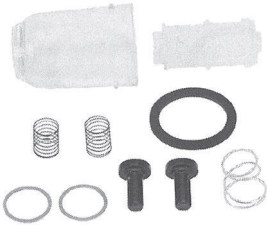
THE ORIGINAL NUMBERS OF THE VEHICLE MANUFACTURER MAY BE USED FOR COMPARISON PURPOSES ONLY AND MUST NOT BE MENTIONED ON INVOICES TO VEHICLE OWNERS.

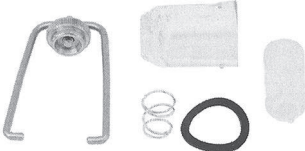

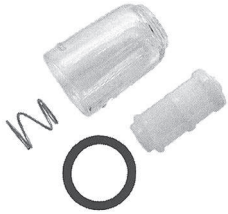





Application	Description	Details	Ref.	Erqo No.
OM 401 LA Euro I, OM402 LA Euro I, OM 441 +A +LA, OM 442 +A +LA,	<ul style="list-style-type: none"> EN Feed pump DE Förderpumpe FR Pompe d'alimentation ES Bomba de alimentació PT Bomba alimentação RU Подкачивающий насос 	repl. Bosch: O 440 011 007	000 091 2190	02.19880 
				
OM 401 / 402 / 403 + A/LA, OM 421 /422/423 + A/LA, OM 441 /442/443 + A/LA	<ul style="list-style-type: none"> EN Hand pump, steel DE Handpumpe, Stahl FR Pompe d'amorçage, acier ES Bomba de mano, acero PT Bomba manual, aço RU Топливоподкачивающий насос, сталь 	repl. Bosch: 2 447 222 000	000 090 0050	02.23093 
				
OM 401 /402 /403 + A/LA, OM 421 /422/423 + A/LA, O M 441 /442 / 443 + A/LA	<ul style="list-style-type: none"> EN Hand pump, steel, with spring DE Handpumpe, Stahl, mit Feder FR Pompe d'amorçage, acier, avec ressort ES Bomba de mano, acero, con resorte PT Bomba manual, aço, com mola RU Ручной насос, Сталь, с Пружина 			02.23094 
				
OM 401 /402 /403 + A/LA, OM 421 /422/423 + A/LA, OM 441 / 442 / 443 + A/LA	<ul style="list-style-type: none"> EN Hand pump, aluminium old version DE Handpumpe, Aluminium alte Ausführung FR Pompe d'amorçage, aluminium ancienne version ES Bomba de mano, aluminio version antigua PT Bomba manual, alumínio versão antiga RU Ручной насос, алюминий старая версия 	repl. Bosch: 2 447 222 020		02.23094 
				
OM 401 / 402 / 403 + A/LA, OM 421 /422/423 + A/LA, OM 441 / 442 / 443 + A/LA	<ul style="list-style-type: none"> EN Hand pump, aluminium DE Handpumpe, Aluminium FR Pompe d'amorçage, aluminium ES Bomba de mano, aluminio PT Bomba manual, alumínio RU Топливоподкачивающий насос, алюминий 	repl. Bosch: 2447 010 033	000 090 8850	02.23095 
				

Injection Pump

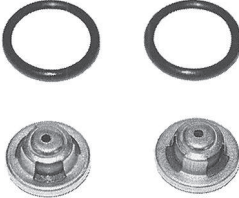
Einspritzpumpe • Pompe à injection • Bomba de alimentación
Bomba inyectara • Впрыскивающий насос







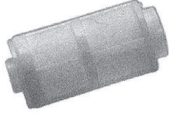

Application	Description	Details	Ref.	Erqo No.
OM 401 /402/403 + A/LA, OM 421 /422/423 + A/LA, OM 441 /442/443 + A/LA	<ul style="list-style-type: none"> EN Repair kit, feed pump DE Reparatursatz, Förderpumpe FR Kit de réparation, pompe d'alimentation ES Kit de reparación, Bomba de alimentación PT Jogo reparo, bomba alimentação RU Ремонтный комплект, топливopодкачивающий насос 		000 091 0840 S1	02.23096 
OM 401 / 402 / 403 + A/LA, OM 421 /422/423 + A/LA, OM 441 /442/443 + A/LA	<ul style="list-style-type: none"> EN Repair kit, feed pump DE Reparatursatz, Förderpumpe FR Kit de réparation, pompe d'alimentation ES Kit de reparación, Bomba de alimentación PT Jogo reparo bomba alimentação RU Ремкомплект для ручного насоса 		000 091 0840 S2	02.23097 
OM 401 /402/403 + A/LA, OM 421 /422/423 + A/LA, OM 441 /442/443 + A/LA	<ul style="list-style-type: none"> EN Repair kit, feed pump DE Reparatursatz, Förderpumpe FR Kit de réparation, pompe d'alimentation ES Kit de reparación, Bomba de alimentación PT Jogo reparo bomba alimentação RU Ремкомплект для ручного насоса 		000 091 0840 S3	02.23098 
OM 401 / 402 / 403 + A/LA, OM 421 /422/423 + A/LA, OM 441 /442/443 + A/LA	<ul style="list-style-type: none"> EN Repair kit, feed pump DE Reparatursatz, Förderpumpe FR Kit de réparation, pompe d'alimentation ES Kit de reparación, Bomba de alimentación PT Jogo reparo, bomba alimentação RU Ремонтный комплект, топливopодкачивающий насос 	repl. Bosch: 2 447 010 017 	000 091 0840	02.23099 
OM 401 /402/403 + A/LA, OM 421 /422/423 + A/LA, OM 441 /442/443 + A/LA	<ul style="list-style-type: none"> EN Repair kit, feed pump DE Reparatursatz, Förderpumpe FR Kit de réparation, pompe d'alimentation ES Kit de reparación, Bomba de alimentación PT Jogo reparo bomba alimentação RU Ремкомплект для ручного насоса 	repl. Bosch: 2 447 010 011 	000 090 0210	02.19856 

THE ORIGINAL NUMBERS OF THE VEHICLE MANUFACTURER MAY BE USED FOR COMPARISON PURPOSES ONLY AND MUST NOT BE MENTIONED ON INVOICES TO VEHICLE OWNERS.

Application	Description	Details	Ref.	Erqo No.
OM 401 / 402 / 403 + A/LA, OM 421 / 422/423 + A/LA, OM 441 / 442 / 443 + A/LA	<ul style="list-style-type: none"> EN Repair kit, feed pump DE Reparatursatz, Förderpumpe FR Kit de réparation, pompe d'alimentation ES Kit de reparación, Bomba de alimentación PT Jogo reparo bomba alimentação RU Ремкомплект для ручного насоса 	repl. Bosch: 2 447 010 016	000 090 0151	02.19867 
				
OM 401 / 402 / 403 + A/LA, OM 421 / 422/423 + A/LA, OM 441 / 442 / 443 + A/LA	<ul style="list-style-type: none"> EN Feed pump repair kit DE Reparatursatz Förderpumpe FR Kit de rép. Pompe d'alimentation ES Kit de reparación bomba de alimentación PT Jogo reparo bomba alimentação RU Ремонтный комплект 	repl. Bosch 2 447 010 044	001 586 1207	02.22065 
				
OM 401 / 402 / 403 + A/LA, OM 421 / 422/423 + A/LA, OM 441 / 442 / 443 + A/LA	<ul style="list-style-type: none"> EN Feed pump repair kit DE Reparatursatz Förderpumpe FR Kit rép. pompe d'alimentation ES Kit de reparación bomba de alimentación PT Jogo reparo bomba alimentação RU Ремкомплект для ручного насоса 	repl. Bosch 2 447 010 021	000 090 0610	02.19857 
				
OM 401 / 402 / 403 + A/LA, OM 421 / 422/423 + A/LA, OM 441 / 442 / 443 + A/LA	<ul style="list-style-type: none"> EN Repair kit, fuel filter DE Reparatursatz, Kraftstofffilter FR Kit de réparation, filtre de carburant ES Kit de reparación, filtro de combustible PT Suporte filtro combustível RU Ремкомплект для фильтра 	repl. Bosch: 2 447 010 027	000 091 1341	02.19879 
				
OM 401 / 402 / 403 + A/LA, OM 421 / 422/423 + A/LA, OM 441 / 442 / 443 + A/LA	<ul style="list-style-type: none"> EN Gasket DE Dichtung FR Joint ES Junta PT Junta RU Уплотнение 		001 074 2280	02.19848 
				

Injection Pump

Einspritzpumpe • Pompe à injection • Bomba de alimentación
Bomba injectara • Впрыскивающий насос

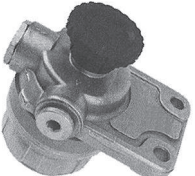
Application	Description	Details	Ref.	Erqo No.
OM 401 /402/403 + A/LA, OM 421 /422/423 + A/LA, OM 441 /442/443 + A/LA	EN Fuel filter DE Kraftstofffilter FR Filtre de carburant ES Filtro de combustible PT Elemento filtro combustível RU Топливный фильтр	repl. Bosch: 1 450 410 011	000 091 0039	02.23100 
				
OM 401 /402/403 + A/LA, OM 421 /422/423 + A/LA, OM 441 /442/443 + A/LA	EN Inspection bowl DE Schauglas FR Verre de filtre ES Mirilla transparente PT Copo válvula manual sangria RU Смотровое стекло	repl. Bosch: 2 459 999 002		02.23101 
				
OM 401 /402/403 + A/LA, OM 421 /422/423 + A/LA, OM 441 /442/443 + A/LA	EN Fuel filter DE Kraftstofffilter FR Filtre de carburant ES Filtro de combustible PT Elemento filtro combustível RU Топливный фильтр	repl. Bosch: 1 457 434 000	000 477 0002	02.23102 
				
OM 422, OM 423 +A +LA	EN Fuel filter DE Kraftstoff filter FR Filtre à gazole ES Filtro de combustible PT Cabeçote filtro combustível RU Топливный фильтр	repl. Bosch: 2 457 434 010	000 477 0702	02.21691 
				
OM 401 LA, OM 402 LA Euro I, OM 441 LA, OM 442 A + LA (motor 661324--)	EN Feed pump DE Handförderpumpe FR Pompe d'amorçage gazole ES Bomba de alimentación manual PT Bomba alimentação RU Ручной подкачивающий насос		000 090 6050	02.19864 
				

THE ORIGINAL NUMBERS OF THE VEHICLE MANUFACTURER MAY BE USED FOR COMPARISON PURPOSES ONLY AND MUST NOT BE MENTIONED ON INVOICES TO VEHICLE OWNERS.

1

Application	Description	Details	Ref.	Erqo No.
OM 401 LA, OM 402 LA, OM 441 + LA, OM 442 + LA	<ul style="list-style-type: none"> EN Fuel pump 300 / 400 l tank / left DE Kraftstoffpumpe 300 / 400 L Tank / links FR Pompe à carburant réservoir gauche 300 / 400 litres ES Bomba de alimentación 300 / 400 L deposito / izquierdo PT Bomba combustível deposito esquerdo 300 / 400 litres RU Топливный насос бак 300/400 л, левый 		000 090 7350	02.19865 

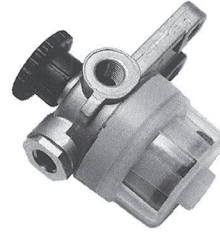





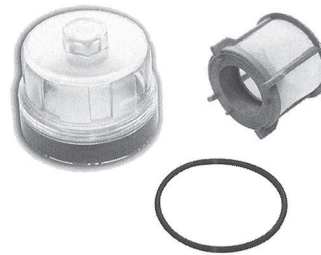

OM 401 LA, OM 402 LA Euro I, OM 441 LA, OM 442 A + L A (motor 661324--)	<ul style="list-style-type: none"> EN Filter repair kit, without filter housing DE Filter Reparatursatz, ohne Filtergehäuse FR Kit préfiltre gazole, sans cuve ES Kit de reparación, Filtro, sin caja del PT Jogo reparo filtro, sem carcaça filtro RU Ремонтный комплект для фильтра, без корпуса 	Hengst E11S04 D65	000 090 0751	02.19868 
---	--	-------------------	--------------	---



OM 401 LA, OM 402 LA Euro I, OM 441 LA, OM 442 A + LA (motor 661324--)	<ul style="list-style-type: none"> EN Filter repair kit, ind. filter housing DE Filter Reparatursatz, einschl. Filtergehäuse FR Kit préfiltre gazole, avec cuve ES Kit de reparación, filtro, con caja del filtro PT Jogo reparo filtro, com carcaça filtro RU Ремонтный комплект для фильтра 		000 090 0751 S	02.23103 
--	---	--	----------------	--

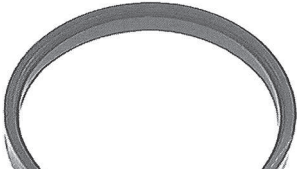

Application	Description	Details	Ref.	Erqo No.
OM 401 LA, OM 402 LA Euro I, OM 441 LA, OM 442 A + LA (motor 661324--)	EN Filter housing DE Filtergehäuse FR Carter de filtre ES Carcasa del Filtro PT Carcaça filtro RU Корпус фильтра		000 092 3303	02.19882 
				
OM 401/421/441 + A/LA, OM 402/422/442 + A/LA, OM 403/423/443 + A/LA	EN Overflow valve DE Überströmventil FR Clapet anti-retour ES Válvula de rebose PT Válvula alívio RU Перепускной клапан	M 14 x 1,5	000 074 7684	02.19851 
				
O M 402 LA, OM 441 LA, OM 443 A/LA	EN Oil seal DE Wellendichtring FR Joint speed ES Anillo retén PT Retentor RU Сальник	35 x 47 x 7 / 7,5	014 997 4747	02.22680 
				
OM 401 /402/403 + A/LA, OM 421 /422/423 + A/LA, OM 441 /442/443 + A/LA	EN O-ring DE O-Ring FR Joint torique ES Junta tórica PT Anel RU Уплотнительное кольцо	7,0 x 3,0 mm	008 997 6145	02.22624 
				
OM 401/421/441 + A/LA, OM 402/422/442 + A/LA, OM 403/423/443 + A/LA -- motor 473000	EN Seal ring old version DE Dichtring alte Ausführung FR Bague d'étanchéité ancienne version ES Retén version antigua PT Anel vedação bomba injetora versão antiga da RU Уплотнительное кольцо старая версия		403 074 0059	02.19844 
				

THE ORIGINAL NUMBERS OF THE VEHICLE MANUFACTURER MAY BE USED FOR COMPARISON PURPOSES ONLY AND MUST NOT BE MENTIONED ON INVOICES TO VEHICLE OWNERS.

Injection Pump

Einspritzpumpe • Pompe à injection • Bomba de alimentación
 Bomba inyectara • Впрыскивающий насос





1

Application	Description	Details	Ref.	Erqo No.
OM 401/402/403 + A/LA, OM 421/422/423 + A/LA, OM 441/442/443 + A/LA	(EN) Oil seal (DE) Wellendichtring (FR) Joint speed (ES) Anillo retén (PT) Retentor (RU) Сальник	94,5 x 105,3 x 9	442 074 0059	02.19845







OM 401/421/441 + A/LA, OM 402/422/442 + A/LA, OM 403/423/443 + A/LA	(EN) Drive gear (DE) Antriebsrad (FR) Roue d'entraînement (ES) Rueda motriz (PT) Engrenagem acionadora (RU) Ведущая шестерня		403 077 0712	02.19853
--	---	--	--------------	----------









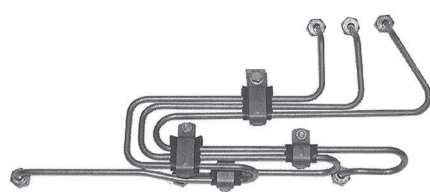
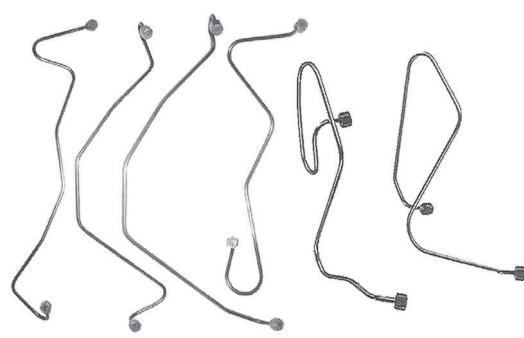
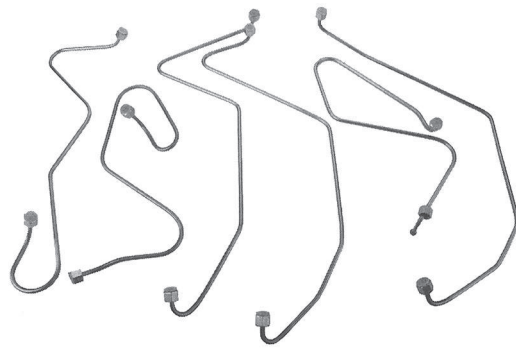
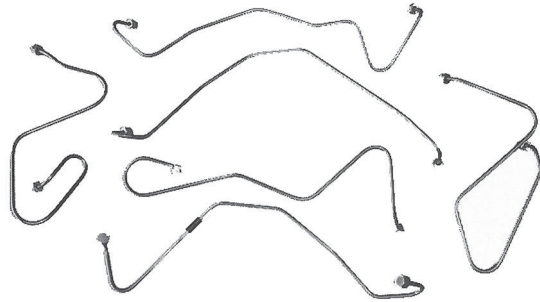

Application	Description	Details	Ref.	Erqo No.
OM 401 /402/403 + A/LA, OM 421 /422/423 + A/LA, OM 441 /442/443 + A/LA	EN Injection line, straight DE Einspritzleitung, gerade FR Flexible injection, droit ES Tubería de inyección, recto PT Tubo injetor, reto RU Топливопровод, прямой	750 mm	403 070 0434	02.19825 
OM 401 /402/403 + A/LA, OM 421 /422/423 + A/LA, OM 441 /442/443 + A/LA	EN Injection line, straight DE Einspritzleitung, gerade FR Flexible injection, droit ES Tubería de inyección, recto PT Tubo injetor, reto RU Топливопровод, прямой	800 mm		02.19825 
OM 401 /402/403 + A/LA, OM 421 /422/423 + A/LA, OM 441 /442/443 + A/LA	EN Injection line, straight DE Einspritzleitung, gerade FR Flexible injection, droit ES Tubería de inyección, recto PT Tubo injetor, reto RU Топливопровод, прямой	1000 mm		02.19825 
OM 401.905, (- motor 264668), OM 401.906/909, OM 401.914-919, OM 421 + A + LA, BM 905-907, (063049 - 133637)	EN Injection line kit DE Einspritzleitung-Satz FR Kit de conduite d'injection ES Juego de tubería de inyección PT Jogo tubos injeção RU Комплект топливопроводов	line 02.19773		02.23104 

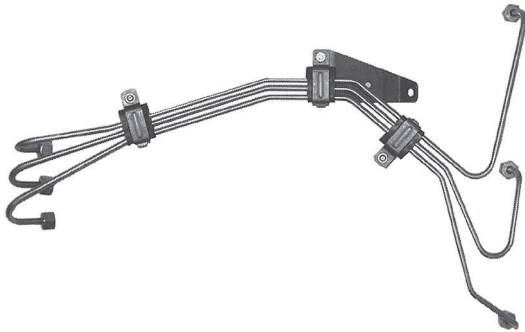
THE ORIGINAL NUMBERS OF THE VEHICLE MANUFACTURER MAY BE USED FOR COMPARISON PURPOSES ONLY AND MUST NOT BE MENTIONED ON INVOICES TO VEHICLE OWNERS.

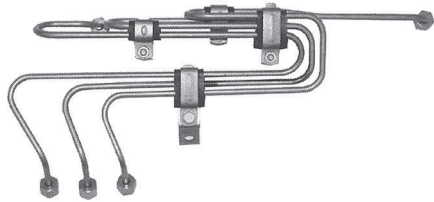
1

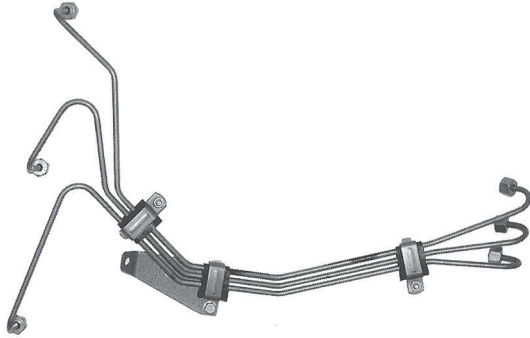

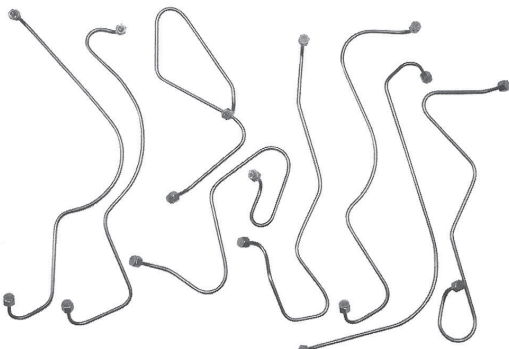





Application	Description	Details	Ref.	Erqo No.
OM 421 + A + LA, BM 905-907, (motor 133638 -), OM 441 BM 905-919	<ul style="list-style-type: none"> EN Injection line kit DE Einspritzleitung-Satz FR Kit de conduite d'injection ES Juego de tubería de inyección PT Jogo tubos injeção RU Комплект топливопроводов 	line 02.19769		02.23105 
OM 421 + A + LA, BM 905-907, (- motor 063048)	<ul style="list-style-type: none"> EN Injection line kit DE Einspritzleitung-Satz FR Kit de conduite d'injection ES Juego de tubería de inyección PT Jogo tubos injeção RU Комплект топливопроводов 	line 02.19801		02.23106 
OM 441 LA BM 951, (- motor 521629)	<ul style="list-style-type: none"> EN Injection line kit DE Einspritzleitung-Satz FR Kit de conduite d'injection ES Juego de tubería de inyección PT Jogo tubos injeção RU Комплект топливопроводов 	line 02.19789		02.23107 
OM 401 LA Euro I, OM 441 A + LA, (motor 521630 -)	<ul style="list-style-type: none"> EN Injection line kit DE Einspritzleitung-Satz FR Kit de conduite d'injection ES Juego de tubería de inyección PT Jogo tubos injeção RU Комплект топливопроводов 	441 070 5533		02.19814 

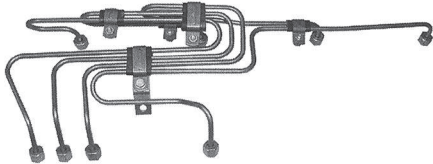

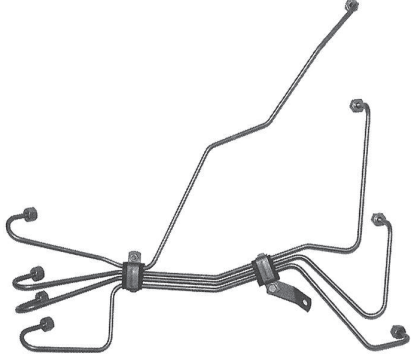

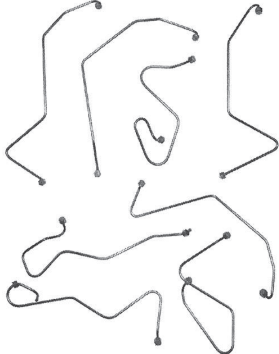

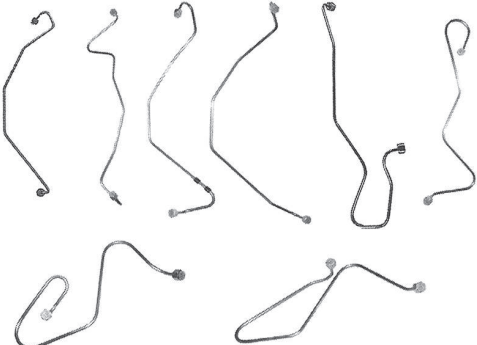

Application	Description	Details	Ref.	Erqo No.
OM 401 LA Euro I, OM 441 A + LA, (motor 521630 -)	<ul style="list-style-type: none"> EN Injection line kit DE Einspritzleitung-Satz FR Kit de conduite d'injection ES Juego de tubería de inyección PT Jogo tubos injeção RU Комплект топливopроводов 		441 070 1133	02.19809 
OM 441 A+LA Euro II	<ul style="list-style-type: none"> EN Injection line kit DE Einspritzleitung-Satz FR Kit de conduite d'injection ES Juego de tubería de inyección PT Jogo tubos injeção RU Комплект топливopроводов 		441 070 6733	02.19816 
OM 441 A+LA Euro II	<ul style="list-style-type: none"> EN Injection line kit DE Einspritzleitung-Satz FR Kit de conduite d'injection ES Juego de tubería de inyección PT Jogo tubos injeção RU Комплект топливopроводов 		441 070 6433	02.19815 
OM402 OM422 (motor 062921-133637)	<ul style="list-style-type: none"> EN Injection line kit DE Einspritzleitung-Satz FR Kit de conduite d'injection ES Juego de tubería de inyección PT Jogo tubos injeção RU Комплект топливopроводов 	line 02.19772 		02.23108 

THE ORIGINAL NUMBERS OF THE VEHICLE MANUFACTURER MAY BE USED FOR COMPARISON PURPOSES ONLY AND MUST NOT BE MENTIONED ON INVOICES TO VEHICLE OWNERS.

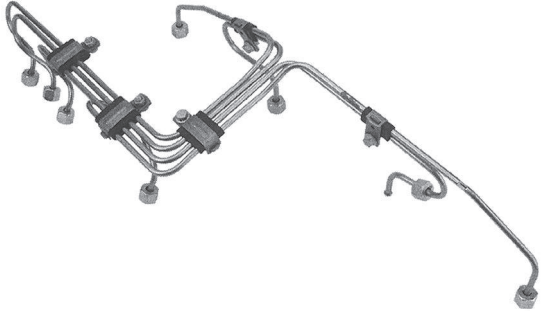

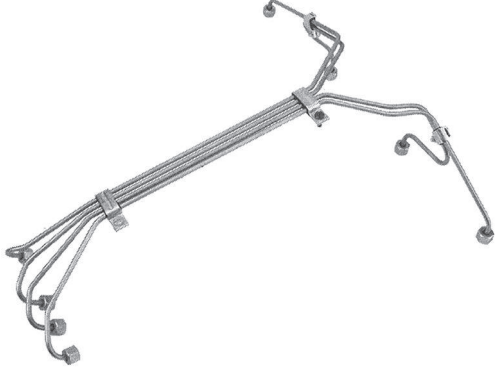

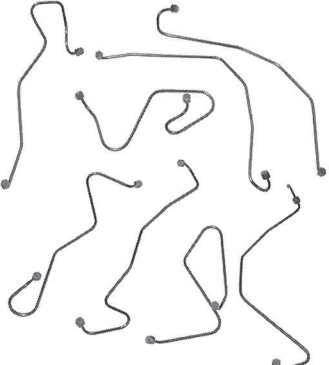
1

Application	Description	Details	Ref.	Erqo No.
OM 402 LA Euro I, OM 442 A + LA (motor 766143-)	<ul style="list-style-type: none"> EN Injection line kit DE Einspritzleitung-Satz FR Kit de conduite d'injection ES Juego de tubería de inyección PT Jogo tubos injeção RU Комплект топливопроводов 		442 070 8333	02.19821 
OM 402 LA Euro I, O M 442 LA	<ul style="list-style-type: none"> EN Injection line kit DE Einspritzleitung-Satz FR Kit de conduite d'injection ES Juego de tubería de inyección PT Jogo tubos injeção RU Комплект топливопроводов 		442 070 8433	02.19823 
OM 422, (- motor 062920), OM 422 A + LA, (- motor 133637)	<ul style="list-style-type: none"> EN Injection line kit DE Einspritzleitung-Satz FR Kit de conduite d'injection ES Juego de tubería de inyección PT Jogo tubos injeção RU Комплект топливопроводов 		line 02.19800	02.23109 
OM 422 + A + LA, (motor 133638 -), OM 442 BM 440, OM 442, BM 905-909/914-917, BM 920-924	<ul style="list-style-type: none"> EN Injection line kit DE Einspritzleitung-Satz FR Kit de conduite d'injection ES Juego de tubería de inyección PT Jogo tubos injeção RU Комплект топливопроводов 		line 02.19775	02.23110 

THE ORIGINAL NUMBERS OF THE VEHICLE MANUFACTURER MAY BE USED FOR COMPARISON PURPOSES ONLY AND MUST NOT BE MENTIONED ON INVOICES TO VEHICLE OWNERS.





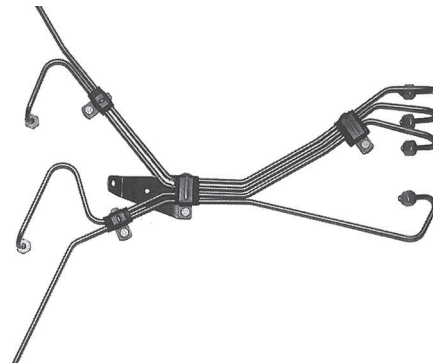
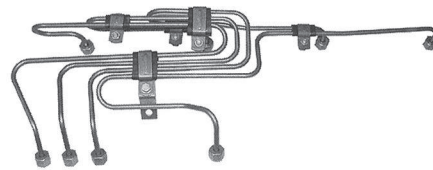
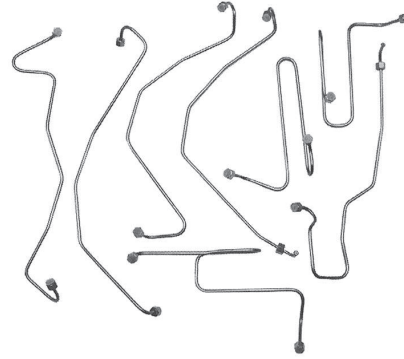
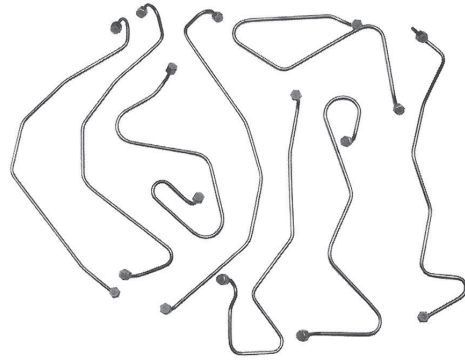

Application	Description	Details	Ref.	Erqo No.
OM 422 A (BM 951) -- motor 024943	<ul style="list-style-type: none"> EN Injection line kit DE Einspritzleitung-Satz FR Kit de conduite d'injection ES Juego para la tubería de inyección PT Jogo tubos injeção RU Комплект топливopроводов 		422 070 0933	02.19780 
OM 422 A (BM 951) -- motor 024943	<ul style="list-style-type: none"> EN Injection line kit DE Einspritzleitung-Satz FR Kit de conduite d'injection ES Juego para la tubería de inyección PT Jogo tubos injeção RU Комплект топливopроводов 		422 070 1033	02.19781 
OM 442, BM 925-929/932-939	<ul style="list-style-type: none"> EN Injection line kit DE Einspritzleitung-Satz FR Kit de conduite d'injection ES Juego de tubería de inyección PT Jogo tubos injeção RU Комплект топливopроводов 	line 02.19796 		02.23111 

1

Application	Description	Details	Ref.	Erqo No.
OM 442 A+LA BM 440, OM 442 A+ LA, BM 941-953, 957-959, BM 962-978, 980-985, (- motor)	<ul style="list-style-type: none"> EN Injection line kit DE Einspritzleitung-Satz FR Kit de conduite d'injection ES Juego de tubería de inyección PT Jogo tubos injeção RU Комплект топливопроводов 	line 02.19779		02,23112 
OM 442 A+LA BM 440, OM 442 A + LA, BM 941-953, 957-959, BM 962-978, 980-985, (motor -)	<ul style="list-style-type: none"> EN Injection line kit DE Einspritzleitung-Satz FR Kit de conduite d'injection ES Juego de tubería de inyección PT Jogo tubos injeção RU Комплект топливопроводов 	line 02.19780		02.23113 
OM 402 LA Euro I, OM 442 A + LA (motor 766143--)	<ul style="list-style-type: none"> EN Injection line kit DE Einspritzleitung-Satz FR Kit de conduite d'injection ES Juego de tubería de inyección PT Jogo tubos injeção RU Комплект топливопроводов 		442 070 8333	02.19822 
OM 442 A + LA (motor 766143--)	<ul style="list-style-type: none"> EN Injection line kit DE Einspritzleitung-Satz FR Kit de conduite d'injection ES Juego de tubería de inyección PT Jogo tubos injeção RU Комплект топливопроводов 		422 070 5433	02.19786 

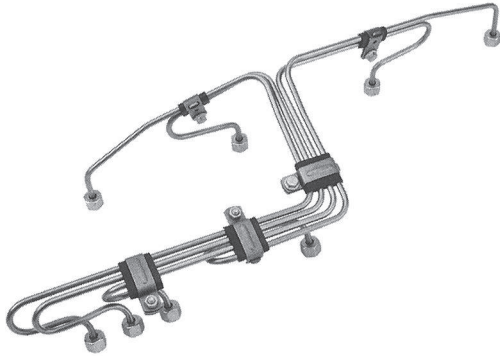

THE ORIGINAL NUMBERS OF THE VEHICLE MANUFACTURER MAY BE USED FOR COMPARISON PURPOSES ONLY AND MUST NOT BE MENTIONED ON INVOICES TO VEHICLE OWNERS.

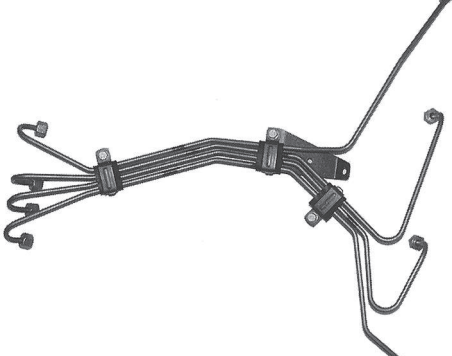
Application	Description	Details	Ref.	Erqo No.
OM 442 LA Euro II	<ul style="list-style-type: none"> EN Injection line kit DE Einspritzleitung-Satz FR Kit de conduite d'injection ES Juego de tubería de inyección PT Jogo tubos injeção RU Комплект топливопроводов 		442 070 8133	02.19820 
				
OM 442 A	<ul style="list-style-type: none"> EN Injection line kit DE Einspritzleitung-Satz FR Kit de conduite d'injection ES Juego de tubería de inyección PT Jogo tubos injeção RU Комплект топливопроводов 		442 070 1333	02.19817 
				
OM 442 A	<ul style="list-style-type: none"> EN Injection line kit DE Einspritzleitung-Satz FR Kit de conduite d'injection ES Juego de tubería de inyección PT Jogo tubos injeção RU Комплект топливопроводов 		442 070 1433	02.19818 
				
OM 442 LA Euro II	<ul style="list-style-type: none"> EN Injection line kit DE Einspritzleitung-Satz FR Kit de conduite d'injection ES Juego de tubería de inyección PT Jogo tubos injeção RU Комплект топливопроводов 		442 070 9633	02.19824 
				

THE ORIGINAL NUMBERS OF THE VEHICLE MANUFACTURER MAY BE USED FOR COMPARISON PURPOSES ONLY AND MUST NOT BE MENTIONED ON INVOICES TO VEHICLE OWNERS.

1

Application	Description	Details	Ref.	Erqo No.
OM 403 BM 900/905/906/ 915/917/919/930/ 932-934 OM 403 BM 916/931/935 (--motor 264668) OM 423 BM 905-908 (--motor 133637)	<ul style="list-style-type: none"> EN Injection line kit DE Einspritzleitung-Satz FR Kit de conduite d'injection ES Juego de tubería de inyección PT Jogo tubos injeção RU Комплект топливопроводов 	line 19769		02.23114

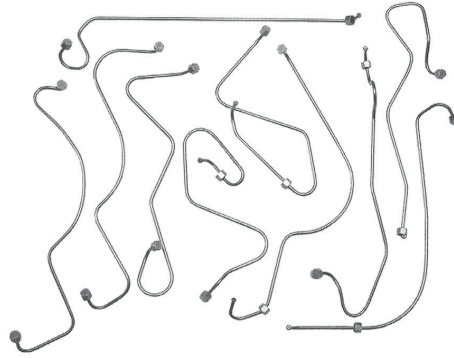

OM 403, BM 916/931/935, (motor 264669 -), OM 423 (motor 133638-), OM 433 + A + LA	<ul style="list-style-type: none"> EN Injection line kit DE Einspritzleitung-Satz FR Kit de conduite d'Injection ES Juego de tubería de inyección PT Jogo tubos injeção RU Комплект топливопроводов 	line 02.19808		02.23115
--	---	---------------	--	----------

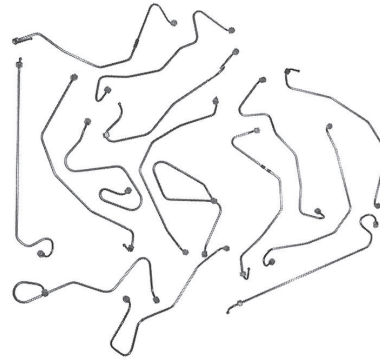



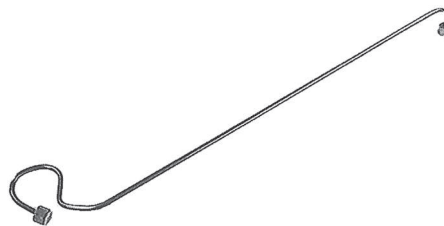

OM 403/423	<ul style="list-style-type: none"> EN Injection line DE Einspritzleitung FR Flexible injection ES Tubería de inyección PT Tubo injeção RU Топливопровод 		403 070 1034	02.19827
------------	---	--	--------------	----------













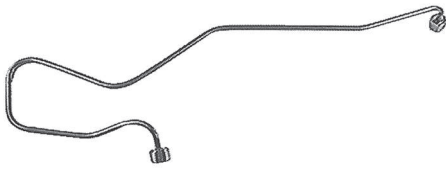

OM 402 /422, OM 403 /423	<ul style="list-style-type: none"> EN Injection line DE Einspritzleitung FR Flexible injection ES Tubería de inyección PT Tubo injeção RU Топливопровод 		403 070 2833	02.19772
-----------------------------	---	--	--------------	----------















THE ORIGINAL NUMBERS OF THE VEHICLE MANUFACTURER MAY BE USED FOR COMPARISON PURPOSES ONLY AND MUST NOT BE MENTIONED ON INVOICES TO VEHICLE OWNERS.

Application	Description	Details	Ref.	Erqo No.
OM 401 /421, OM 402/422, OM 403 / 423	<ul style="list-style-type: none"> EN Injection line DE Einspritzleitung FR Flexible injection ES Tubería de inyección PT Tubo injeção RU Топливопровод 		403 070 2733	02.19771 
OM 401 /421, OM 402 / 422, OM 403/423	<ul style="list-style-type: none"> EN Injection line DE Einspritzleitung FR Flexible injection ES Tubería de inyección PT Tubo injeção RU Топливопровод 		403 070 2633	02.19770 
OM 401 /421, OM 402 / 422, OM 403/423	<ul style="list-style-type: none"> EN Injection line DE Einspritzleitung FR Flexible injection ES Tubería de inyección PT Tubo injeção RU Топливопровод 		403 070 2533	02.19769 
OM 403/423/443	<ul style="list-style-type: none"> EN Injection line DE Einspritzleitung FR Flexible injection ES Tubería de inyección PT Tubo injeção RU Топливопровод 		403 070 0934	02.19826 











THE ORIGINAL NUMBERS OF THE VEHICLE MANUFACTURER MAY BE USED FOR COMPARISON PURPOSES ONLY AND MUST NOT BE MENTIONED ON INVOICES TO VEHICLE OWNERS.

Application	Description	Details	Ref.	Erqo No.
OM 402/422/442, OM 403 / 423 / 443	<ul style="list-style-type: none"> EN Injection line DE Einspritzleitung FR Flexible injection ES Tubería de inyección PT Tubo injeção RU Топливопровод 		403 070 7433	02.19776 
OM 401 /421 /441, OM 402/422/442, OM 403 / 423 / 443	<ul style="list-style-type: none"> EN Injection line DE Einspritzleitung FR Flexible injection ES Tubería de inyección PT Tubo injeção RU Топливопровод 		403 070 5133	02.19774 
OM 401 /421 /441, OM 402/422/442, OM 403 / 423 / 443	<ul style="list-style-type: none"> EN Injection line DE Einspritzleitung FR Flexible injection ES Tubería de inyección PT Tubo injeção RU Топливопровод 		403 070 6033	02.19775 
OM 401 /421 /441, OM 402/422/442, OM 403 / 423 / 443	<ul style="list-style-type: none"> EN Injection line DE Einspritzleitung FR Flexible injection ES Tubería de inyección PT Tubo injeção RU Топливопровод 		403 070 4933	02.19773 
OM 403/423/443	<ul style="list-style-type: none"> EN Injection line DE Einspritzleitung FR Flexible injection ES Tubería de inyección PT Tubo injeção RU Топливопровод 		423 070 2833	02.19808 
OM 402/422/442, OM 443	<ul style="list-style-type: none"> EN Injection line DE Einspritzleitung FR Flexible injection ES Tubería de inyección PT Tubo injeção RU Топливопровод 		422 070 7833	02.19795 











Application	Description	Details	Ref.	Erqo No.
OM 401 /421 / 441, OM 402 / 422 / 442, OM 443	EN Injection line DE Einspritzleitung FR Flexible injection ES Tubería de inyección PT Tubo injeção RU Топливопровод		422 070 7733	02.19794 
OM 401 /421 / 441, OM 402/422 / 442, OM 443	EN Injection line DE Einspritzleitung FR Flexible injection ES Tubería de inyección PT Tubo injeção RU Топливопровод		422 070 7633	02.19793 
OM 401 /421 / 441, OM 402/422 / 442, OM 443	EN Injection line DE Einspritzleitung FR Flexible injection ES Tubería de inyección PT Tubo injeção RU Топливопровод		422 070 7533	02.19792 
OM 442 A + LA	EN Injection line DE Einspritzleitung FR Flexible injection ES Tubería de inyección PT Tubo injeção RU Топливопровод		422 070 6633	02.19790 
OM 441 LA, OM 442 A + LA	EN Injection line DE Einspritzleitung FR Flexible injection ES Tubería de inyección PT Tubo injeção RU Топливопровод		422 070 6533	02.19789 
OM 442 A + LA	EN Injection line DE Einspritzleitung FR Flexible injection ES Tubería de inyección PT Tubo injeção RU Топливопровод		422 070 6433	02.19788 

THE ORIGINAL NUMBERS OF THE VEHICLE MANUFACTURER MAY BE USED FOR COMPARISON PURPOSES ONLY AND MUST NOT BE MENTIONED ON INVOICES TO VEHICLE OWNERS.

1











Application	Description	Details	Ref.	Erqo No.
OM 441 LA, OM 442 A + LA	EN Injection line DE Einspritzleitung FR Flexible injection ES Tubería de inyección PT Tubo injeção RU Топливопровод		422 070 6333	02.19787 
OM 402 LA Euro I, OM 442 A + LA	EN Injection line DE Einspritzleitung FR Flexible injection ES Tubería de inyección PT Tubo injeção RU Топливопровод		422 070 6733	02.19791 
OM 402 LA Euro I, OM 441 LA, OM 442 A + LA	EN Injection line DE Einspritzleitung FR Flexible injection ES Tubería de inyección PT Tubo injeção RU Топливопровод		421 070 3033	02.19777 
OM 402 LA Euro I, OM 441 LA, OM 442 A + LA	EN Injection line DE Einspritzleitung FR Flexible injection ES Tubería de inyección PT Tubo injeção RU Топливопровод		421 070 3133	02.19778 
OM 402 LA Euro I, OM 441 LA, OM 442 A + LA	EN Injection line DE Einspritzleitung FR Flexible injection ES Tubería de inyección PT Tubo injeção RU Топливопровод		421 070 3233	02.19779 

THE ORIGINAL NUMBERS OF THE VEHICLE MANUFACTURER MAY BE USED FOR COMPARISON PURPOSES ONLY AND MUST NOT BE MENTIONED ON INVOICES TO VEHICLE OWNERS.



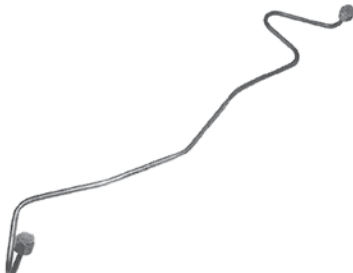

Application	Description	Details	Ref.	Erqo No.
OM 402 LA Euro I, OM 442 A + LA	<ul style="list-style-type: none"> EN Injection line DE Einspritzleitung FR Flexible injection ES Tubería de inyección PT Tubo injeção RU Топливопровод 		442 070 6133	02.19819 
OM 401 LA Euro I, OM 402 LA Euro I, OM 441 LA, OM 442 A + LA	<ul style="list-style-type: none"> EN Injection line DE Einspritzleitung FR Flexible injection ES Tubería de inyección PT Tubo injeção RU Топливопровод 		441 070 2533	02.19810 
OM 401 LA Euro I, OM 402 LA Euro I, OM 441 LA, OM 442 A + LA	<ul style="list-style-type: none"> EN Injection line DE Einspritzleitung FR Flexible injection ES Tubería de inyección PT Tubo injeção RU Топливопровод 		441 070 2633	02.19811 
OM 401 LA Euro I, OM 402 LA Euro I, OM 441 LA, OM 442 A + LA	<ul style="list-style-type: none"> EN Injection line DE Einspritzleitung FR Flexible injection ES Tubería de inyección PT Tubo injeção RU Топливопровод 		441 070 2733	02.19811 
OM 423 LA	<ul style="list-style-type: none"> EN Injection line DE Einspritzleitung FR Flexible injection ES Tubería de inyección PT Tubo injeção RU Топливопровод 		423 070 2233	02.19805 

THE ORIGINAL NUMBERS OF THE VEHICLE MANUFACTURER MAY BE USED FOR COMPARISON PURPOSES ONLY AND MUST NOT BE MENTIONED ON INVOICES TO VEHICLE OWNERS.

1













Application	Description	Details	Ref.	Erqo No.
OM 423 LA	<ul style="list-style-type: none"> EN Injection line DE Einspritzleitung FR Flexible injection ES Tubería de inyección PT Tubo injeção RU Топливопровод 		423 070 2133	02.19804 
OM 423 LA	<ul style="list-style-type: none"> EN Injection line DE Einspritzleitung FR Flexible injection ES Tubería de inyección PT Tubo injeção RU Топливопровод 		423 070 2233	02.19805 
OM 423 LA	<ul style="list-style-type: none"> EN Injection line DE Einspritzleitung FR Flexible injection ES Tubería de inyección PT Tubo injeção RU Топливопровод 		423 070 2333	02.19807 
OM 422 A + LA, OM 442 + LA	<ul style="list-style-type: none"> EN Injection line DE Einspritzleitung FR Flexible injection ES Tubería de inyección PT Tubo injeção RU Топливопровод 		422 070 5233	02.19785 
OM 422 A + LA, OM 441, OM 442 + LA	<ul style="list-style-type: none"> EN Injection line DE Einspritzleitung FR Flexible injection ES Tubería de inyección PT Tubo injeção RU Топливопровод 		422 070 5133	02.19784 

THE ORIGINAL NUMBERS OF THE VEHICLE MANUFACTURER MAY BE USED FOR COMPARISON PURPOSES ONLY AND MUST NOT BE MENTIONED ON INVOICES TO VEHICLE OWNERS.









Application	Description	Details	Ref.	Erqo No.
OM 422 A + LA, OM 441, OM 442 + LA	<ul style="list-style-type: none"> EN Injection line DE Einspritzleitung FR Flexible injection ES Tubería de inyección PT Tubo injeção RU Топливопровод 		422 070 5033	02.19783 
OM 422 A + LA, OM 441, OM 442 + LA	<ul style="list-style-type: none"> EN Injection line DE Einspritzleitung FR Flexible injection ES Tubería de inyección PT Tubo injeção RU Топливопровод 		422 070 4933	02.19782 
OM 422 + A + LA, OM 423 LA, OM 442	<ul style="list-style-type: none"> EN Injection line DE Einspritzleitung FR Flexible injection ES Tubería de inyección PT Tubo injeção RU Топливопровод 		423 070 0333	02.19796 
OM 421, OM 422 + A + LA, OM 423 LA, OM 441, OM 442	<ul style="list-style-type: none"> EN Injection line DE Einspritzleitung FR Flexible injection ES Tubería de inyección PT Tubo injeção RU Топливопровод 		423 070 0433	02.19797 
OM 421, OM 422 + A + LA, OM 423 LA, OM 441, OM 442	<ul style="list-style-type: none"> EN Injection line DE Einspritzleitung FR Flexible injection ES Tubería de inyección PT Tubo injeção RU Топливопровод 		423 070 0533	02.19798 

THE ORIGINAL NUMBERS OF THE VEHICLE MANUFACTURER MAY BE USED FOR COMPARISON PURPOSES ONLY AND MUST NOT BE MENTIONED ON INVOICES TO VEHICLE OWNERS.

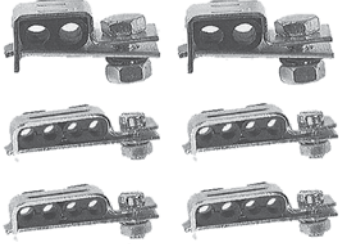
1

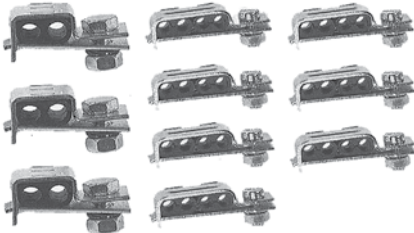
Application	Description	Details	Ref.	Erqo No.
OM 421, OM 422 + A + LA, OM 423 LA, OM 441, OM 442	<ul style="list-style-type: none"> EN Injection line DE Einspritzleitung FR Flexible injection ES Tubería de inyección PT Tubo injeção RU Топливопровод 		423 070 0633	02.19799 
				
OM 401 /402 /403 + A/LA, OM 421 /422/423 + A/LA, OM 441 / 442 / 443 + A/LA	<ul style="list-style-type: none"> EN Clamp, injection lines DE Klemme, Einspritzleitungen FR Collier, flexibles d'Injection ES Grapa, Conducto de inyección PT Abraçadeira, tubo injeção RU Клемма для топливопровода 	for 2 lines	000 995 1407	02.22567 
				
OM 401 / 402 / 403 + A/LA, OM 421 /422/423 + A/LA, OM 441 / 442 / 443 + A/LA	<ul style="list-style-type: none"> EN Clamp, injection lines DE Klemme, Einspritzleitungen FR Collier, flexibles d'Injection ES Grapa, Conducto de inyección PT Abraçadeira, tubo injeção RU Клемма для топливопровода 	for 3 lines	000 995 1107	02.22566 
				
OM 401 /402 /403 + A/LA, OM 421 /422/423 + A/LA, OM 441 / 442 / 443 + A/LA	<ul style="list-style-type: none"> EN Clamp, injection lines DE Klemme, Einspritzleitungen FR Collier, flexibles d'Injection ES Grapa, Conducto de inyección PT Abraçadeira, tubo injeção RU Клемма для топливопровода 	for 4 lines	000 995 1807	02.22568 
				
OM 401 / 402 / 403 + A/LA, OM 421 /422/423 + A/LA, OM 441 / 442 / 443 + A/LA	<ul style="list-style-type: none"> EN Clamps, kit, injection lines DE Klemmen, Satz, Einspritzleitungen FR Agraphes, kit, flexibles d'injection ES Pinzas, juego, inyectoros PT Jogo abraçadeira, tubo injeção RU Зажимы, Комплект 		000 995 1807 S	02.23116 
		  		

THE ORIGINAL NUMBERS OF THE VEHICLE MANUFACTURER MAY BE USED FOR COMPARISON PURPOSES ONLY AND MUST NOT BE MENTIONED ON INVOICES TO VEHICLE OWNERS.

Application	Description	Details	Ref.	Erqo No.
OM 401 /402/403 + A/LA, OM 421 /422/423 + A/LA, OM 441 /442/443 + A/LA	<p>EN Clamps, kit, injection lines</p> <p>DE Klemmen, Satz, Einspritzleitungen</p> <p>FR Agraphes, kit, flexibles d'injection</p> <p>ES Pinzas, juego, inyectores</p> <p>PT Jogo abraçadeira, tubo injeção</p> <p>RU Зажимы, Комплект</p>		000 995 1807 S1	02.23117 
OM 401 /402/403 + A/LA, OM 421 /422/423 + A/LA, OM 441 /442/443 + A/LA	<p>EN Clamps, kit, injection lines</p> <p>DE Klemmen, Satz, Einspritzleitungen</p> <p>FR Agraphes, kit, flexibles d'injection</p> <p>ES Pinzas, juego, inyectores</p> <p>PT Jogo abraçadeira, tubo injeção</p> <p>RU Зажимы, Комплект</p>		000 995 1807 S2	02.23118 
OM 401 /402/403 + A/LA, OM 421 /422/423 + A/LA, OM 441 /442/443 + A/LA	<p>EN Clamps, kit, injection lines</p> <p>DE Klemmen, Satz, Einspritzleitungen</p> <p>FR Agraphes, kit, flexibles d'injection</p> <p>ES Pinzas, juego, inyectores</p> <p>PT Jogo abraçadeira, tubo injeção</p> <p>RU Зажимы, Комплект</p>		000 995 1807 S3	02.23119 
OM 401 /402/403 + A/LA, OM 421 /422/423 + A/LA, OM 441 /442/443 + A/LA	<p>EN Fuel hose</p> <p>DE Kraftstoffschlauch</p> <p>FR Tuyau de carburant</p> <p>ES Manguito de combustible</p> <p>PT Mangueira</p> <p>RU Топливный шланг</p>	3,2 x 7,0 mm, in lengths of 25 m	011 997 7782	02.22757 
OM 401 /402/403 + A/LA, OM 421 /422 /423 + A/LA, OM 441 /442/443 + A/LA	<p>EN Fuel hose</p> <p>DE Kraftstoffschlauch</p> <p>FR Tuyau de carburant</p> <p>ES Manguito de combustible</p> <p>PT Mangueira combustivel</p> <p>RU Топливный шланг</p>	3,2 x 9,0 mm, in lengths of 25 m	427 997 0982	02.22767 

THE ORIGINAL NUMBERS OF THE VEHICLE MANUFACTURER MAY BE USED FOR COMPARISON PURPOSES ONLY AND MUST NOT BE MENTIONED ON INVOICES TO VEHICLE OWNERS.

Application	Description	Details	Ref.	Erqo No.
OM 401/421/441 + A/LA, OM 402/422/442 + A/LA, OM 403/423/443 + A/LA	<p>EN Cylinder, 6 mm thread</p> <p>DE Zylinder, 6 mm Gewinde</p> <p>FR Cylindre, filetage 6 mm</p> <p>ES Cilindro, rosca 6 mm</p> <p>PT Cilindro, rosca 6 mm</p> <p>RU Цилиндр, резьба 6 мм</p>		000 072 0112	02.19834 
OM 401/421/441 + A/LA, OM 402/422/442 + A/LA, OM 403/423/443 + A/LA	<p>EN Cylinder, 8 mm thread</p> <p>DE Zylinder, 8 mm Gewinde</p> <p>FR Cylindre, filetage 8 mm</p> <p>ES Cilindro, rosca 8 mm</p> <p>PT Cilindro, rosca 8 mm</p> <p>RU Цилиндр, резьба 8 мм</p>		000 072 1512	02.19835 
OM 401 LA, OM 441 + A/LA -- motor 734141	<p>EN Cylinder</p> <p>DE Zylinder</p> <p>FR Cylindre</p> <p>ES Cilindro</p> <p>PT Cilindro</p> <p>RU Цилиндр</p>		000 070 1983	02.19832 
OM 401/402 LA, OM 441 + A/LA, OM 442 LA motor 734142 --	<p>EN Cylinder</p> <p>DE Zylinder</p> <p>FR Cylindre</p> <p>ES Cilindro</p> <p>PT Cilindro</p> <p>RU Цилиндр</p>		000 070 2183	02.19833 
OM 401/421/441 + A/LA, OM 402/422/442 + A/LA, OM 403/423/443 + A/LA	<p>EN Cylinder, complete</p> <p>DE Zylinder, komplett</p> <p>FR Cylindre, complet</p> <p>ES Cilindro, completo</p> <p>PT Cilindro, completo</p> <p>RU Цилиндр, в сборе</p>			
OM 401/402, OM 422/442 -- motor 266368	<p>EN Rod</p> <p>DE Stange</p> <p>FR Tige</p> <p>ES Barra</p> <p>PT Haste</p> <p>RU Штанга</p>		402 072 0124	02.19840 

Application	Description	Details	Ref.	Erqo No.
OM 401/441, OM 402/442 motor 266369 --	EN Rod DE Stange FR Tige ES Barra PT Haste RU Штанга		422 072 0424	02.19842 
OM 403, OM 423 + A + LA, OM 443 + A + LA	EN Rod DE Stange FR Tige ES Barra PT Haste RU Штанга		403 072 0324	02.19841 
OM 403/423/443	EN Push rod DE Druckstange FR Tige de culbuteur ES Barra de presión PT Haste RU Штанга	M 8 x 1,25 / l = 172 mm 	423 072 0324	02.19843 
OM 401 /402/403 + A/LA, OM 421 /422/423 + A/LA, OM 441 /442/443 + A/LA	EN Ball socket DE Kugelpfanne FR Rotule ES Cazoleta esférica PT Terminal freio motor RU Шаровой подпятник	M 6 / Ø 10 mm 	000 991 2422	02.22518 
OM 401 /402/403 + A/LA, OM 421 /422/423 + A/LA, OM 441 /442/443 + A/LA	EN Ball socket DE Kugelpfanne FR Rotule ES Rótula PT Terminal freio motor RU Шаровой подпятник новое исполнение	M 8 	422 991 0022	02.22525 
OM 401 LA Euro I, OM 402 LA Euro I, OM 441 LA, OM 442 LA	EN Ball socket, left hand thread DE Kugelpfanne, Linksgewinde FR Rotule, filetage à gauche ES Cazoleta esférica, Rosca izquierda PT Terminal, rosca lado esquerdo RU Шаровой подпятник, Левая резьба	M 6 / Ø 10 mm 	000 991 5222	02.22519 

THE ORIGINAL NUMBERS OF THE VEHICLE MANUFACTURER MAY BE USED FOR COMPARISON PURPOSES ONLY AND MUST NOT BE MENTIONED ON INVOICES TO VEHICLE OWNERS.

Application	Description	Details	Ref.	Erqo No.
OM 401/402/403 + A/LA, OM 421/422/423 + A/LA, OM 441/442/443 + A/LA	<ul style="list-style-type: none"> EN Bushing DE Buchse FR Bague ES Casquillo PT Vucha RU Втулка 	16 x 12 x 15	403 992 0001	02.22532



OM 401 /402 /403 + A/LA, OM 421 /422/423 + A/LA, OM 441 / 442 / 443 + A/LA	<ul style="list-style-type: none"> EN Spring DE Feder FR Ressort ES Muelle PT Mola espiral RU Пружина 		442 993 5110	02.22553
--	---	--	--------------	----------



OM 401 /402/403 + A/LA, OM 421 /422/423 + A/LA, OM 441 /442/443 + A/LA	<ul style="list-style-type: none"> EN Spring DE Feder FR Ressort ES Muelle PT Mola espiral RU Пружина 		422 993 0110	02.22552
--	---	--	--------------	----------







OM 401/421/441, OM 402/422/442, OM 403/423/443	<ul style="list-style-type: none"> EN Lever DE Hebel FR Levier ES Palanca PT Garfo embreagem RU Рычаг 		441 070 0621	02.19766
--	---	--	--------------	----------

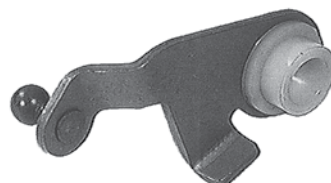







OM 401/402/403, OM 421/422/423, OM 441 + LA, OM 442 + A/LA, OM 443	<ul style="list-style-type: none"> EN Lever DE Hebel FR Levier ES Palanca PT Garfo embreagem RU Рычаг 		403 070 8321	02.19765
--	---	--	--------------	----------



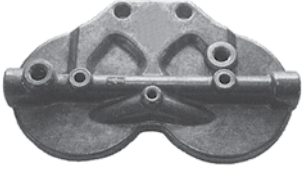





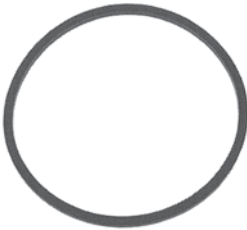

Application	Description	Details	Ref.	Erqo No.
OM 401/402/403, OM 422	<ul style="list-style-type: none"> EN Fuel filter DE Kraftstofffilter FR Filtre de carburant ES Filtro de combustible PT Filtro combustível RU Топливный фильтр 		001 477 4801	02.21689 
				1
OM 401/421/441 + A/LA, OM 402/422/442 + A/LA, OM 403/423/443 + A/LA	<ul style="list-style-type: none"> EN Fuel filter DE Kraftstofffilter FR Filtre de carburant ES Filtro de combustible PT Filtro combustível RU Топливный фильтр 	2 x 1,01	442 090 0352	02.19873 
OM 401/402/403, OM 422	<ul style="list-style-type: none"> EN Filter cover DE Filterdeckel FR Dessus de filtre ES Tapa de filtra PT Cabeçote filtro RU Крышка фильтра 		000 477 3508	02.21692 
OM 401/421/441 + A/LA, OM 402/422/442 + A/LA, OM 403/423/443 + A/LA	<ul style="list-style-type: none"> EN Filter head DE Filterkopf FR Tête de filtre ES Cabezal de filtro PT Cabeçote filtro RU Крышка фильтра 		442 092 0008	02.23120 

THE ORIGINAL NUMBERS OF THE VEHICLE MANUFACTURER MAY BE USED FOR COMPARISON PURPOSES ONLY AND MUST NOT BE MENTIONED ON INVOICES TO VEHICLE OWNERS.

1

Application	Description	Details	Ref.	Erqo No.
OM 401/421/441 + A/LA, OM 402/422/442 + A/LA, OM 403/423/443 + A/LA	<p>EN Filter head for old version</p> <p>DE Filterkopf für alte Ausführung</p> <p>FR Tête de filtre pour ancienne version</p> <p>ES Cabeza del filtro para version antigua</p> <p>PT Cabeçote filtro para versão antiga</p> <p>RU Крышка фильтра для старая версия</p>		422 092 0108	02.19883 
				
OM 401/402/403, OM 422 OM 441 + LA, OM 442/443	<p>EN Fuel filter</p> <p>DE Kraftstofffilter</p> <p>FR Filtre à gazole</p> <p>ES Filtro de combustible</p> <p>PT Elemento filtra combustível</p> <p>RU Топливный фильтр</p>	repl. M+H: BFU 700 X	000 090 1151	02.19869 
				
OM 401/421/441 + A/LA, OM 402/422/442 + A/LA, OM 403/423/443 + A/LA	<p>EN Fuel filter</p> <p>DE Kraftstofffilter</p> <p>FR Filtre à gazole</p> <p>ES Filtro de combustible</p> <p>PT Elemento filtro combustível</p> <p>RU Топливный фильтр</p>	repl. M+H: BFU 900 X	000 090 1451	02.19871 
				
OM 401/421/441 + A/LA, OM 402/422/442 + A/LA, OM 403/423/443 + A/LA	<p>EN Seal ring for double cartridge filter</p> <p>DE Dichtring für Doppel-Filter</p> <p>FR Bague detanchéité pour filtres doubles</p> <p>ES Retén para filtro de doble cartucho</p> <p>PT Anel para refil de filtro duplo</p> <p>RU Уплотнительное кольцо для двойных фильтров</p>		000 477 3580	02.21695 
				

THE ORIGINAL NUMBERS OF THE VEHICLE MANUFACTURER MAY BE USED FOR COMPARISON PURPOSES ONLY AND MUST NOT BE MENTIONED ON INVOICES TO VEHICLE OWNERS.

Application	Description	Details	Ref.	Erqo No.
OM 401/402/403, OM 422 OM 441 + LA, OM 442/443	EN Seal ring DE Dichtring FR Bague d'étanchéité ES Anillo obturador PT Anel RU Уплотнительное кольцо		000 477 3180	02.21694 
OM 401/421/441 + A/LA, OM 402/422/442 + A/LA, OM 403/423/443 + A/LA	EN Filter housing DE Filtergehäuse FR Carter de filtre ES Caja del filtro PT Carcaça filtro RU Корпус фильтра		422 090 0007	02.19855 
OM 422 A + LA, OM 442	EN Bracket DE Halter FR Support ES Sujeción PT Suporte RU Кронштейн		442 090 1641	02.19858 
NG/MK/SK	EN Screw DE Schraube FR Vis ES Tornillo PT Parafuso RU Болт	M 8 x 75	000 990 5304	02.22434 
OM 401/421/441 + A/LA, OM 402/422/442 + A/LA, OM 403/423/443 + A/LA	EN Screw with air vent bore DE Schraube mit Entlüftungsbohrung FR Vis avec trou de ventilation ES Tornillo con rosca ventilada PT Parafuso com furo para saída de ar RU Болт вентиляционным отверстием	M 8 x 10 mm	000 074 5171	02.19846 







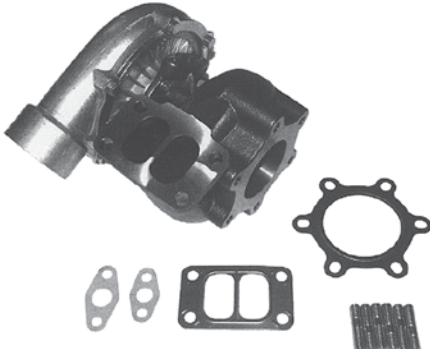

Fuel Filter

Kraftstofffilter • Filtre carburant • Filtro combustibile
 Elemento filtro, combustivel • Топливный фильтр











1

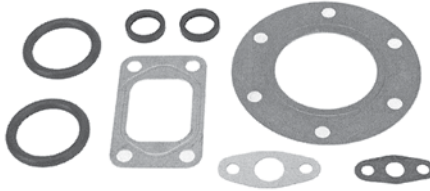

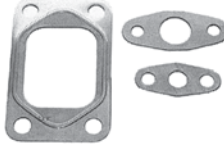







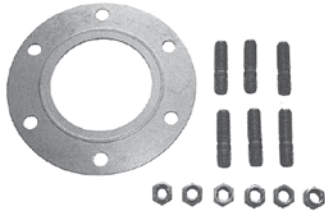

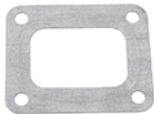
Application	Description	Details	Ref.	Erqo No.
OM 401/421/441 + A/LA,	EN Screw	M 8 x 13 mm	442 074 0071	02.19847 
OM 402/422/442 + A/LA,	DE Entlüfterschraube			
OM 403/423/443 + A/LA,	FR Vis de ventilateur			
	ES Tornillo de purga			
	PT Parafuso			
	RU ВИНТ			

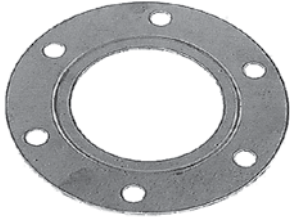

Application	Description	Details	Ref.	Erqo No.
OM 422 A/LA, OM 442 A	<ul style="list-style-type: none"> EN Turbocharger DE Turbolader FR Turbocompresseur ES Turbocompresor PT Turbo RU Турбоагнетатель 		003 096 5599	02.19905 
OM 401 LA (Euro 1)	<ul style="list-style-type: none"> EN Turbocharger DE Turbolader FR Turbocompresseur ES Turbocompresor PT Turbo RU Турбоагнетатель 		004 096 3699	02.19908 
OM 442 LA	<ul style="list-style-type: none"> EN Turbocharger DE Turbolader FR Turbocompresseur ES Turbocompresor PT Turbo RU Турбоагнетатель 		004 096 6099	02.19909 
OM 442 LA, BM 442.985/989/992, 993/994	<ul style="list-style-type: none"> EN Turbocharger DE Turbolader FR Turbocompresseur ES Turbocompresor PT Turbo RU Турбоагнетатель 		004 096 0999	02.19907 

Sample





Application	Description	Details	Ref.	Erqo No.
OM 442 LA, -12.2003	<ul style="list-style-type: none"> EN Turbocharger DE Turbolader FR Turbocompresseur ES Turbocompresor PT Turbo RU Турбоагнетатель 		005 096 9399	02.19911 
OM 401/421/441 A/LA	<ul style="list-style-type: none"> EN Mounting kit, turbocharger DE Befestigungssatz, Turbolader FR Jeu de fixations, Turbocompresseur ES Juego de fijación, Turbocompresor PT Kit montagem, turbo RU Крепежный комплект, Турбоагнетатель 		422 144 0280 S1	02.23121 
OM 402/422/442 A/LA	<ul style="list-style-type: none"> EN Gasket kit, turbocharger DE Dichtsatz, Turbolader FR Kit de joints, Turbocompresseur ES Juego de juntas, Turbocompresor PT Jogo junta, Turbo RU Комплект уплотнителей, Турбоагнетатель 		422 142 0080 S3	02.23122 
OM 422/442 A/LA -- motor 122240, -- motor 120996	<ul style="list-style-type: none"> EN Repair kit, turbocharger DE Reparatursatz, Turbolader FR Kit de réparation, Turbocompresseur ES Kit de reparación, Turbocompresor PT Jogo reparo, turbo RU Ремонтный комплект, Турбоагнетатель 		422 142 0080 S1	02.23123 
OM 422/442 A/LA motor 122241--, motor 120997--	<ul style="list-style-type: none"> EN Repair kit, turbocharger DE Reparatursatz, Turbolader FR Kit de réparation, Turbocompresseur ES Kit de reparación, Turbocompresor PT Jogo reparo, turbo RU Ремонтный комплект, Турбоагнетатель 		422 142 0080 S2	02.23124 

Application	Description	Details	Ref.	Erqo No.
OM 401/402 A/LA, OM 421/422 A/LA, OM 441/442 A/LA	<ul style="list-style-type: none"> EN Gasket kit DE Dichtsatz FR Kit de joints ES Juego de juntas PT Jogo junta RU Комплект уплотнителей 		422 144 0280 S2	02.23125 
OM 401 A/LA, OM 421 A/LA, OM 441 A/LA	<ul style="list-style-type: none"> EN Gasket, turbocharger DE Dichtung, Turbolader FR Joint, Turbocompresseur ES Junta, Turbocompresor PT Junta, turbo RU Уплотнение, Турбоагнетатель 		421 142 0180	02.20039 
OM 402/422/442 A/LA, OM 403/423/443 A/LA	<ul style="list-style-type: none"> EN Gasket, turbocharger DE Dichtung, Turbolader FR Joint, turbocompresseur ES Junta, turbocompresor PT Junta, turbo RU Уплотнение, Турбоагнетатель 		422 142 0080	02.20040 
OM 401/402 A/LA, OM 421/422/423 A/LA, OM 441/442/443 A/LA	<ul style="list-style-type: none"> EN Gasket, turbocharger DE Dichtung, Turbolader FR Joint, Turbocompresseur ES Junta, Turbocompresor PT Junta, turbo RU Уплотнение, Турбоагнетатель 		422 144 0280	02.20048 
OM 401/402 A/LA, OM 421/422/423 A/LA, OM 441/442/443 A/LA	<ul style="list-style-type: none"> EN Gasket DE Dichtung FR Joint ES Junta PT Junta RU Уплотнение 		442 187 0180	02.20138 
OM 401/402 A/LA, OM 421/422/423 A/LA, OM 441/442/443 A/LA	<ul style="list-style-type: none"> EN Gasket DE Dichtung FR Joint ES Junta PT Junta RU Уплотнение 		442 187 0080	02.20137 



THE ORIGINAL NUMBERS OF THE VEHICLE MANUFACTURER MAY BE USED FOR COMPARISON PURPOSES ONLY AND MUST NOT BE MENTIONED ON INVOICES TO VEHICLE OWNERS.

Application	Description	Details	Ref.	Erqo No.
OM 421/441 A	<ul style="list-style-type: none"> EN Gasket, turbo-charger DE Dichtung, Turbolader FR Joint, Turbocompresseur ES Junta, Turbocompresor PT Junta, turbo RU Уплотнение, Турбоагнетатель 		421 142 0080	02.20038 
				
OM 401/402/403 + A/LA, OM 421/422/423 + A/LA, OM 441/442/443 + A/LA	<ul style="list-style-type: none"> EN Oil seal DE Wellendichtring FR Joint speed ES Anillo retén PT Retentor RU Сальник 	22,9 x 31,5 x 5,9	422 997 0040	02.22620 
				
OM 402 LA, OM 442 A/LA	<ul style="list-style-type: none"> EN O-ring DE O-Ring FR Joint torique ES Junta tórica PT Anel RU Уплотнительное кольцо 	45,0 x 8,0 mm	006 997 4848	02.22708 
				
OM 401 LA, OM 421 ABM951, OM 423 LA BM 950, OM 441 A BM 950/953, OM 441 LA, OM 443 A BM 940, OM 443 LA BM 980	<ul style="list-style-type: none"> EN O-ring DE O-Ring FR Joint torique ES Junta tórica PT Anel RU Уплотнительное кольцо 	52,0 x 8,0 mm	021 997 5248	02.22730 
				
OM 422/442 A/LA -- motor 122240, -- motor 120996	<ul style="list-style-type: none"> EN Screw, turbocharger at exhaust manifold DE Schraube, Turbolader an Auspuffkrümmer FR Vis, turbocompresseur sur échappement ES Tornillo, turbo a colector de escape PT Parafuso, turbo ao coletor escape RU Болт, турбоагнетатель к выпускному коллектору 	M 10 x 40 mm	005 990 0201	02.22414 
				







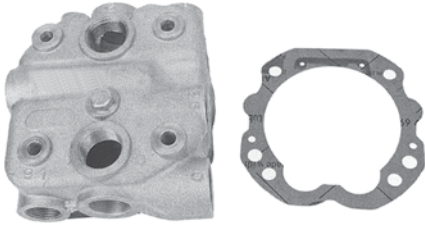

Sample

Application	Description	Details	Ref.	Erqo No.
OM 422/442 A/LA motor 122241--, motor 120997--	EN Screw, turbocharger at exhaust manifold DE Schraube, Turbolader an Auspuffkrümmer FR Vis, turbocompresseur sur échappement ES Tornillo, turbo a colector de escape PT Parafuso, turbo ao coletor escape RU Болт, турбоагнетатель к выпускному коллектору	M 10 x 40, 8.8	005 990 5101	02.22415 
OM 401 LA, OM 421 / OM 441 A + LA, OM 422 / OM 442 A + LA	EN Stud, turbocharger at exhaust manifold DE Stehbolzen, Turbolader an Auspuffkrümmer FR Boulon d'entretoise, turbocompresseur sur échappement ES Tornillo, turbo a colector de escape PT Prisioneiro, turbo ao coletor escap RU Распорный болт, турбоагнетатель к выпускному коллектору	M 10	001 990 4205	02.22456 
OM 401, 402 LA Euro I, OM 423 LA, OM 441 LA, OM 442 A + LA, OM 443 A + LA	EN Stud bolt DE Stehbolzen FR Boulon ES Espárrago PT Prisioneiro RU Шпилька	M 10 x 42 / 12	000 990 6005	02.22455 
OM 401 LA, OM 421 / OM 441 A + LA, OM 422 / OM 442 A + LA	EN Nut DE Mutter FR Ecrou ES Tuerca PT Porca RU Гайка	M 10	000 990 3150	02.22471 
OM 401/421/441 A/LA, OM 423/443 A/LA	EN Connecting pipe DE Verbindungsrohr FR Tube de raccordement ES Tubo de unión PT Tubo de conexão RU Соединительная трубка		421 098 0116	02.19912 

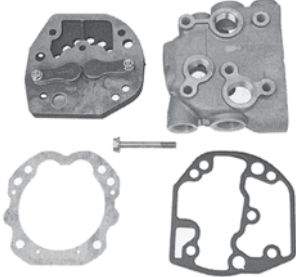

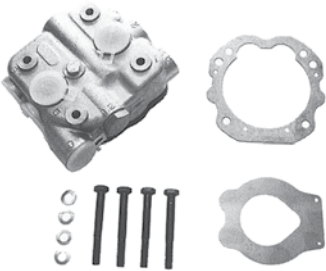

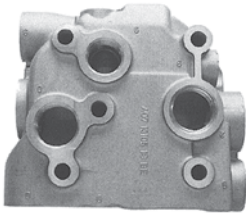

THE ORIGINAL NUMBERS OF THE VEHICLE MANUFACTURER MAY BE USED FOR COMPARISON PURPOSES ONLY AND MUST NOT BE MENTIONED ON INVOICES TO VEHICLE OWNERS.





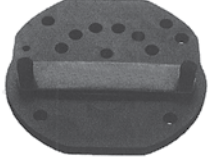

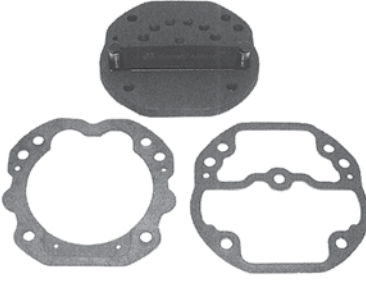
Application	Description	Details	Ref.	Erqo No.
OM 402/422/442 A/LA	EN Connecting pipe DE Verbindungsrohr FR Tube de raccordement ES Tubo de unión PT Tubo de conexão RU Соединительная трубка		422 098 0016	02.19913 
OM 401 LA Euro I, OM 402 LA Euro I, OM 421 A, OM 422 A + LA, OM 423 LA, OM 441 A + LA, OM 442 A + LA, OM 443 A + L A	EN Suction hose DE Ansaugschlauch FR Tuyau d'aspiration ES Tubo flexible de aspiración PT Mangueira sucção RU Рукав воздухозаборника	83 mm	366 997 0283	02.22772 



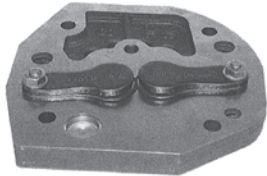

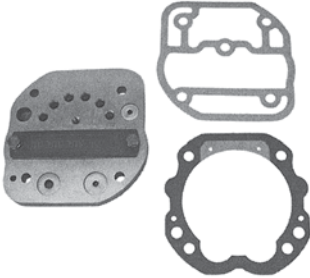
Application	Description	Details	Ref.	Erqo No.
OM 401/402 LA, OM 421/441 + A/LA, OM 422/442 + A/LA, OM 423/443 + A/LA	<ul style="list-style-type: none"> EN Cylinder head, complete DE Zylinderkopf, komplett FR Culasse, complet ES Culata, completa PT Cabeçote, completo RU Головка блока цилиндров, в сборе 		000 130 4119	02.19934 
OM 401/402 LA, OM 421/441 + A/LA, OM 422/442 + A/LA, OM 423/443 + A/LA	<ul style="list-style-type: none"> EN Cylinder head, complete DE Zylinderkopf, komplett FR Culasse, complet ES Culata, completa PT Cabeçote, completo RU Головка блока цилиндров, в сборе 		447 130 0019	02.19937 
OM 401/402/403, OM 421/422/423, OM 441/442/443	<ul style="list-style-type: none"> EN Cylinder head, complete for 90 mm water cooled liner DE Zylinderkopf, komplett für 90 mm wassergekühlte Laufbuchse FR Culasse, complet pour 90 mm refroidi à l'eau chemise de cylindre ES Culata, completa para 90 mm refrigerado por agua PT Cabeçote, completo para 90 mm camisa molhada RU Головка блока цилиндров, в сборе для 90 мм втулки цилиндра с водяным охлаждением 		000 130 2619	02.19932 
OM 401/402 LA, OM 421/441 + A/LA OM 422/442 + A/LA OM 423/443 + A/LA	<ul style="list-style-type: none"> EN Cylinder head for 90 mm air cooled liner DE Zylinderkopf für 90 mm luftgekühlte Laufbuchse FR Culasse pour 90 mm air refroidi chemise de cylindre ES Culata para 90 mm refrigerado por aire PT Cabeçote para 90 mm camisa refrigerada ar RU Головка блока цилиндров для 90 мм гильза с воздушным охлаждением 		407 130 0519	02.19935 



THE ORIGINAL NUMBERS OF THE VEHICLE MANUFACTURER MAY BE USED FOR COMPARISON PURPOSES ONLY AND MUST NOT BE MENTIONED ON INVOICES TO VEHICLE OWNERS.



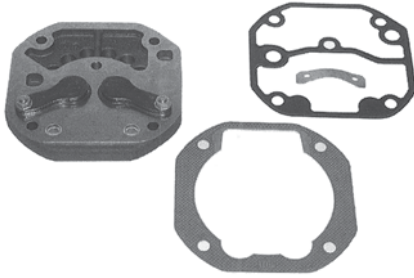



Application	Description	Details	Ref.	Erqo No.
1 OM 421/422/423, OM 441/442, OM 401/441/442 LA, OM 442 A	<p>EN Cylinder head for 100 mm air cooled liner</p> <p>DE Zylinderkopf für 100 mm luftgekühlte Laufbuchse Culasse</p> <p>FR pour 100 mm air refroidi chemise de cylindre</p> <p>ES Culata para 100 mm refrigerado por aire</p> <p>PT Cabeçote para 100 mm camisa refrigerada ar</p> <p>RU Головка блока цилиндров для 100 мм гильза с воздушным охлаждением</p>		442 130 3219	02.19936 
OM 401/402/403, OM 421/422/423, OM 441/442/443	<p>EN Valve plate, 90 mm watercooled liner</p> <p>DE Ventilplatte, 90 mm wassergekühlte Laufbuchse</p> <p>FR lame de soupape, 90 mm refroidi à l'eau chemise de cylindre</p> <p>ES Placa de válvula, 90 mm refrigerado por agua</p> <p>PT Borboleta intermediária do compressor, 90 mm camisa molhada</p> <p>RU Пластина клапана, 90 мм втулки цилиндра с водяным охлаждением</p>		000 130 5020	02.19939 
OM 401/402/403, OM 421/422/423, OM 441/442/443	<p>EN Repair kit, cylinder head, compressor, 90 mm watercooled liner</p> <p>DE Reparatursatz, Zylinderkopf, Kompressor, 90 mm wassergekühlte Laufbuchse</p> <p>FR Kit de réparation, Culasse, Compresseur, 90 mm refroidi à l'eau chemise de cylindre</p> <p>ES Kit de reparación, culata, compresor, 90 mm refrigerado por agua</p> <p>PT Jogo reparo, cabeçote compressor, 90 mm camisa molhada</p> <p>RU Ремонтный комплект, ГБЦ, 90 мм втулки цилиндра с водяным охлаждением</p>		402 130 0320	02.19944 

Application	Description	Details	Ref.	Erqo No.
OM 401/402 LA, OM 421/441 + A/LA OM 422/442 + A/LA OM 423/443 + A/LA	<p>EN Valve plate, 90 mm air cooled liner</p> <p>DE Ventilplatte, 90 mm luftgekühlte Laufbuchse</p> <p>FR Lame de soupape, 90 mm air refroidi chemise de cylindre</p> <p>ES Placa de válvula, 90 mm refrigerado por aire</p> <p>PT Carcaça válvula, 90 mm camisa resfriada a ar</p> <p>RU Пластина клапана, 90 мм гильза с воздушным охлаждением</p>		447 130 0020	02.23127 
OM 401/402 LA, OM 421/441 + A/LA, OM 422/442 + A/LA, OM 423/443 + A/LA	<p>EN Repair kit, disc valve</p> <p>DE Reparatursatz, Lamellenventil</p> <p>FR Kit de réparation, Soupape à lamelles</p> <p>ES Kit de reparación, Válvula de discos</p> <p>PT Jogo reparo, disco válvula</p> <p>RU Ремонтный комплект, Пластинчатый клапан</p>		000 130 7620	02.19940 
OM 401/402 LA, OM 421/441 + A/LA, OM 422/442 + A/LA, OM 423/443 + A/LA	<p>EN Repair kit, cylinder head, compressor, 90 mm air cooled liner</p> <p>DE Reparatursatz, Zylinderkopf, Kompressor, 90 mm luftgekühlte Laufbuchse</p> <p>FR Kit de réparation, Culasse, Compresseur, 90 mm air refroidi chemise de cylindre</p> <p>ES Kit de reparación, Culata, compresor, 90 mm refrigerado por aire</p> <p>PT Jogo reparo, cabeçote compressor, 90 mm camisa resfriada a ar</p> <p>RU Пластина клапана, 90 мм гильза с воздушным охлаждением</p>		442 130 0720	02.19947 

Application	Description	Details	Ref.	Erqo No.
OM 421/422/423, OM 441/442, OM 401/441/442 LA, OM 442 A	<p>EN Valve plate, 100 mm air cooled liner</p> <p>DE Lamellenventil, 100 mm luftgekühlte Laufbuchse</p> <p>FR lame de soupape, 100 mm air refroidi chemise de cylindre</p> <p>ES Placa de válvula, 100 mm refrigerado por aire</p> <p>PT Carcaça válvula, 100 mm camisa resfriada a ar</p> <p>RU Пластинчатый клапан, 100 мм гильза с воздушным охлаждением</p>		442 130 0620	02.23126 

OM 421/422/423, OM 441/442, OM 401/441/442 LA, OM 442 A	<p>EN Repair kit, cylinder head, compressor, 100 mm air cooled liner</p> <p>DE Reparatursatz, Zylinderkopf, Kompressor, 100 mm luftgekühlte Laufbuchse</p> <p>FR Kit de réparation, Culasse, Compresseur, 100 mm air refroidi chemise de cylindre</p> <p>ES Kit de reparación, Culata, compresor, 100 mm refrigerado por aire</p> <p>PT Jogo reparo, cabeçote compressor, 100 mm camisa resfriada a ar</p> <p>RU Пластина клапана, 100 мм гильза с воздушным охлаждением</p>		441 130 0220	02.19945 
---	--	--	--------------	--







OM 401/402/403, OM 421/422/423, OM 441/442/443	<p>EN Repair kit, cylinder head, compressor</p> <p>DE Reparatursatz, Zylinderkopf, Kompressor</p> <p>FR Kit de réparation, culasse, compresseur</p> <p>ES Kit de reparación, Culata, Compresor</p> <p>PT Jogo reparo, cabeçote compressor</p> <p>RU Ремкомплект, Компрессор</p>			02.23128 
--	---	--	--	---







Application	Description	Details	Ref.	Erqo No.
OM 401/402 LA, OM 421/441 + A/LA OM 422/442 + A/LA OM 423/443 + A/LA	<p>EN Valve disc kit, 90 mm air cooled liner</p> <p>DE Lamellensatz, 90 mm luftgekühlte Laufbuchse</p> <p>FR Jeu de lamelles, 90 mm air refroidi chemise de cylindre</p> <p>ES Juego de láminas, 90 mm refrigerado por aire</p> <p>PT Junta com palheta compressor, 90 mm camisa resfriada a ar</p> <p>RU Комплект пластин, 90 мм гильза с воздушным охлаждением</p>		447 130 0020 S	02.23129 
OM 421/422/423, OM 441/442, OM 401/441/442 LA, OM 442 A	<p>EN Valve disc kit, 100 mm air cooled liner</p> <p>DE Lamellensatz, 100 mm luftgekühlte Laufbuchse</p> <p>FR Jeu de lamelles, 100 mm air refroidi chemise de cylindre</p> <p>ES Juego de láminas, 100 mm refrigerado por aire</p> <p>PT Junta com palheta compressor, 100 mm camisa resfriada a ar</p> <p>RU Комплект пластин, 100 мм гильза с воздушным охлаждением</p>		441 130 0220 S5	02.23130 
OM 421/422/423, OM 441/442, OM 401/441/442 LA, OM 442 A	<p>EN Suction disc, 100 mm air cooled liner</p> <p>DE Sauglamelle, 100 mm luftgekühlte Laufbuchse</p> <p>FR Joint d'admission, 100 mm air refroidi chemise de cylindre</p> <p>ES Lámina de aspiración, 100 mm refrigerado por aire</p> <p>PT Junta compressor, 100 mm camisa resfriada a ar</p> <p>RU Всасывающая пластина, 100 мм гильза с воздушным охлаждением</p>		000 131 4631	02.23131 





1

Application	Description	Details	Ref.	Erqo No.
OM 401/402/403, OM 421/422/423, OM 441/442/443	<p>EN Valve disc, 90 mm watercooled liner</p> <p>DE Lamelle, 90 mm wassergekühlte Laufbuchse</p> <p>FR Lamelle, 90 mm refroidi à l'eau chemise de cylindre</p> <p>ES Lámina, 90 mm refrigerado por agua</p> <p>PT Palheta compressor, 90 mm camisa molhada</p> <p>RU Пластина, 90 мм втулки цилиндра с водяным охлаждением</p>		000 131 3831	02.19975 
OM 401/402/403, OM 421/422/423, OM 441/442/443	<p>EN Valve disc, 90 mm liner</p> <p>DE Lamelle, 90 mm Laufbuchse</p> <p>FR Lamelle, 90 mm chemise</p> <p>ES Lámina, 90 mm camisa</p> <p>PT Junta compressor, 90 mm camisa</p> <p>RU Пластина, 90 мм гильзой цилиндра</p>		000 131 4631	02.19976 
OM 401/402 LA, OM 421/441 +A/LA OM 422/442+ A/LA OM 423/443+ A/LA	<p>EN Valve disc, 90/100 mm air cooled liner</p> <p>DE Lamelle, 90/100 mm luftgekühlte Laufbuchse</p> <p>FR Lamelle, 90/100 mm air refroidi chemise de cylindre</p> <p>ES Lámina, 90/100 mm refrigerado por aire</p> <p>PT Palheta do compressor, 90/100 mm camisa resfriada a ar</p> <p>RU Пластина, 90/100 мм гильза с воздушным охлаждением</p>		441 130 0220 S7	02.23132 







THE ORIGINAL NUMBERS OF THE VEHICLE MANUFACTURER MAY BE USED FOR COMPARISON PURPOSES ONLY AND MUST NOT BE MENTIONED ON INVOICES TO VEHICLE OWNERS.

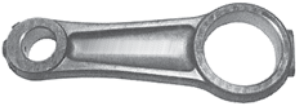

Application	Description	Details	Ref.	Erqo No.
OM 401/402/403, OM 421/422/423, OM 441/442/443	<ul style="list-style-type: none"> EN Piston and liner kit water cooled 90 mm DE Kolben-Laufbuchsensatz wassergekühlt 90 mm FR Kit piston et chemise refroidi à l'eau 90 mm ES Juego de pistón y camisa refrigerado por agua 90 mm PT Kit compressor molhada 90 mm RU Комплект гильз цилиндра с водяным охлаждением 90 мм 		402 130 0608	02.19919 
OM 401/402 LA, OM 421/441 + A/LA OM 422/442 + A/LA OM 423/443 + A/LA	<ul style="list-style-type: none"> EN Piston and liner kit air cooled 90 mm DE Kolben-Laufbuchsensatz luftgekühlt 90 mm FR Kit piston et chemise refroidi à l'air 90 mm ES Juego de pistón y camisa refrigerado por aire 90 mm PT Kit compressor resfriada a ar 90 mm RU Комплект гильз цилиндра с воздушным охлаждением 90 мм 		442 130 0008	02.19923 
OM 421/422/423, OM 441/442, OM 401/441/442 LA, OM 442 A	<ul style="list-style-type: none"> EN Piston and liner kit air cooled 100 mm DE Kolben-Laufbuchsensatz luftgekühlt 100 mm FR Kit piston et chemise refroidi à l'air 100 mm ES Juego de pistón y camisa refrigerado por aire 100 mm PT Kit compressor resfriada a ar 100 mm RU Комплект гильз цилиндра с воздушным охлаждением 100 мм 		441 130 0008	02.19922 
OM 401/402/403, OM 421/422/423, OM 441/442/443	<ul style="list-style-type: none"> EN Expansion plug DE Verschlussdeckel FR Bouchon ES Tapa de cierre PT Vujão tampa radiador RU Крышка 	Ø 25,2 mm	403 997 0620	02.22584 

Application	Description	Details	Ref.	Erqo No.		
<p>1</p> <p>OM 401/402/403, OM 421/422/423, OM 441/442/443</p>	<p>EN Piston ring kit old version, 4 piston rings, 90 mm watercooled liner</p> <p>DE Kolbenringsatz alte Ausführung, 4 Kolbenringe, 90 mm wassergekühlte Laufbuchse</p> <p>FR Jeu de segments ancienne version, 4 Jeu de bagues de piston, 90 mm refroidi à l'eau chemise de cylindre</p> <p>ES Juego de segmentos de pistón versión antigua, 4 segmentos de émbolo, 90 mm camisa refrigerado por agua</p> <p>PT Jogo anel pistão versão anterior, 4 anelos pistão, 90 mm camisa molhada</p> <p>RU Комплект поршневых колец масляного фильтра, 4 Поршневое кольцо, 90 мм втулки цилиндра с водяным охлаждением</p>	repl. Mahle 004 14 VO		<p>02.23133</p> 		
						
	<p>OM 401/402 LA, OM 421/441 +A/LA OM 422/442+ A/LA OM 423/443+A/LA</p>	<p>EN Piston ring kit, STD</p> <p>DE Kolbenringsatz, STD</p> <p>FR Jeu de segments, STD</p> <p>ES Juego de anillos de pistón, STD</p> <p>PT Jogo anel pistão, STD</p> <p>RU Комплект поршневых колец, STD</p>	repl. Wabco: 411 042 001 2; 90 mm	000 131 8211	<p>02.19958</p> 	
						
		<p>OM 421/422/423, OM 441/442, OM 401/441/442 LA OM 442 A</p>	<p>EN Piston ring kit, oil scraper ring = 4 mm for 100 mm air cooled liner</p> <p>DE Kolbenringsatz, Ölabstreifring = 4 mm für 100 mm luftgekühlte Laufbuchse</p> <p>FR Jeu de segments, segment fendu 4 mm pour 100 mm air refroidi chemise de cylindre</p> <p>ES Juego de segmentos de pistón, Aro rascador de aceite = 4 mm para 100 mm refrigerado por aire</p> <p>PT Jogo anel pistão, anel raspador óleo = 4 mm para 100 mm camisa resfriada a ar</p> <p>RU Комплект поршневых колец, Маслосъемное кольцо = 4 мм для 100 мм гильза с воздушным охлаждением</p>	repl. Mahle 004 13 NO	000 131 9411	<p>02.23134</p> 
						







Application	Description	Details	Ref.	Erqo No.
OM 421/422/423, OM 441/442, OM 401/441/442 LA OM 442 A	<p>EN Piston ring kit, oil scraper ring = 3 mm for 100 mm air cooled liner</p> <p>DE Kolbenringsatz, Ölabbstreifring = 3 mm für 100 mm luftgekühlte Laufbuchse</p> <p>FR Jeu de segments, segment fendu 3 mm pour 100 mm air refroidi chemise de cylindre</p> <p>ES Juego de segmentos de pistón, aro rascador de aceite = 3 mm para 100 mm refrigerado por aire</p> <p>PT Jogo anel pistão, anel raspador óleo = 3 mm para 100 mm camisa resfriada a ar</p> <p>RU Комплект поршневых колец, Маслосъемное кольцо = 3 мм для 100 мм гильза с воздушным охлаждением</p>	repl. Mahle 004 26 N0	001 131 1311	02.23135 
OM 401/402 LA, OM 421/441 + A/LA OM 422/442 + A/LA OM 423/443 + A/LA	<p>EN Con rod 90 mm watercooled + aircooled liner</p> <p>DE Pleuelstange 90 mm wassergekühlte + luftgekühlte Laufbuchse</p> <p>FR Bielle 90 mm refroidi à l'eau + air refroidi chemise de cylindre</p> <p>ES Biela 90 mm camisa refrigerado por agua + aire</p> <p>PT Biela 90 mm camisa resfriada a ar + molhada</p> <p>RU Шатун 90 мм втулки цилиндра с водяным охлаждением + с воздушным охлаждением</p>		403 130 2816	02.19928 
OM 401/402/403, OM 421/422/423, OM 441/442/443	<p>EN Con rod for 2 cylinder compressor with 90 mm watercooled liner</p> <p>DE Pleuelstange für 2 Zylinder Kompressor mit 90 mm wassergekühlte Laufbuchse</p> <p>FR Bielle pour 2 cylindre compresseur avec 90 mm refroidi à l'eau chemise de cylindre</p> <p>ES Biela para 2 cilindro compresor con 90 mm refrigerado por agua camisa de cilindro</p> <p>PT Biela para 2 cilindros compresor com 90 mm camisa molhada</p> <p>RU Шатун для цилиндра Компрессор с 90 мм водяным охлаждением</p>		403 130 2716	02.19927 

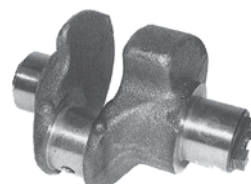
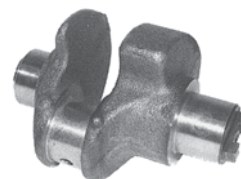



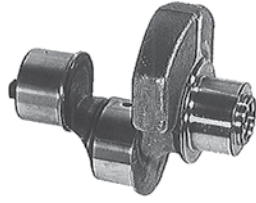



THE ORIGINAL NUMBERS OF THE VEHICLE MANUFACTURER MAY BE USED FOR COMPARISON PURPOSES ONLY AND MUST NOT BE MENTIONED ON INVOICES TO VEHICLE OWNERS.



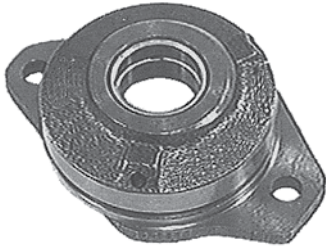

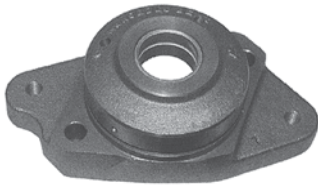
Application	Description	Details	Ref.	Erqo No.
1 OM 421/422/423, OM 441/442, OM 401/441/442 LA, OM 442 A	EN Con rod 100 mm air cooled liner DE Pleuelstange 100 mm luftgekühlte Laufbuchse FR Bielle 100 mm air refroidi chemise de cylindre ES Biela 100 mm refrigerado por aire PT Biela 100 mm camisa resfriada a ar RU Шатун 100 мм гильза с воздушным охлаждением		442 131 0217	02.19969 
OM 401/402 LA, OM 421/441 + A/LA OM 422/442 +A/LA OM 423/443 +A/LA	EN Con rod bearing, 2 pc, 90 mm watercooled + aircooled liner DE Pleuellager, 2 Stück, 90 mm wassergekühlte + luftgekühlte Laufbuchse FR Coussinet de bielle, 2 pièces, 90 mm refroidi à l'eau + air refroidi chemise de cylindre ES Cojinete de biela, 2 unidades, 90 mm refrigerado por agua y aire PT Bronzina biela, 2 peças, 90 mm camisa resfriada a ar + molhada RU Подшипник шатуна, 90 мм гильза цилиндра, водяное + воздушное охлаждение		403 131 0233	02.19977 
OM 401/402 LA, OM 421/441 + A/LA OM 422/442+A/LA OM 423/443 +A/LA	EN Bearing half, 90 mm watercooled + aircooled liner DE Pleuellagerhälfte, 90 mm wassergekühlte + luftgekühlte Laufbuchse FR 1/2 Coussinet de bielle, 90 mm refroidi à l'eau + air refroidi chemise de cylindre ES Semicojinete de biela, 90 mm refrigerado por agua y aire PT Bronzina biela, 90 mm camisa resfriada a ar - molhada RU Половина шатунного подшипника, 90 мм гильза цилиндра, водяное + воздушное охлаждение		403 131 0233	02.19978 

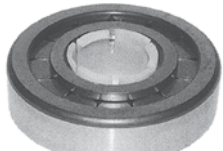





Application	Description	Details	Ref.	Erqo No.
OM 401/402 LA, OM 421/441 + A/LA OM 422/442 + A/LA OM 423/443 + A/LA	<p>EN Screw, 90 mm watercooled + aircooled liner</p> <p>DE Schraube, 90 mm wassergekühlte + luftgekühlte Laufbuchse</p> <p>FR Vis, 90 mm refroidi à l'eau + air refroidi chemise de cylindre</p> <p>ES Tornillo, 90 mm refrigerado por agua + aire</p> <p>PT Parafuso, 90 mm camisa resfriada a ar + molhada</p> <p>RU Болт, 90 мм гильза цилиндров, водяное + воздушное охлаждение</p>	M 8 x 1,25	403 990 0210	02.22460 
OM 401/402/403, OM 421/422/423, OM 441/442/443	<p>EN Crankshaft old version, 90 mm watercooled liner</p> <p>DE Kurbelwelle alte Ausführung, 90 mm wassergekühlte Laufbuchse</p> <p>FR Vilebrequin vieille version, pour 90 mm refroidi à l'eau chemise de cylindre</p> <p>ES Cigüeñal, versión antigua, 90 mm refrigerado por agua</p> <p>PT Virabrequim, versão antiga, 90 mm camisa molhada</p> <p>RU Коленвал Старая версия, 90 мм гильза цилиндра с водяным охлаждением</p>		403 131 1016	02.19967 
OM 401/402/403, OM 421/422/423, OM 441/442/443	<p>EN Crankshaft new version with lubricate bore, 90 mm watercooled liner</p> <p>DE Kurbelwelle neue Ausführung mit Schmierbohrung, 90 mm wassergekühlte Laufbuchse</p> <p>FR Vilebrequin nouvelle version, pour 90 mm refroidi à l'eau chemise de cylindre</p> <p>ES Cigüeñal, nueva versión, 90 mm refrigerado por agua</p> <p>PT Virabrequim, versão nova, 90 mm camisa molhada</p> <p>RU Коленвал Новая версия с каналом для подачи масла, 90 мм гильза цилиндра с водяным охлаждением</p>		403 130 0114	02.19924 





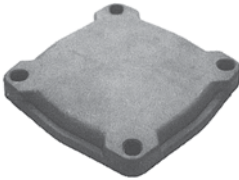

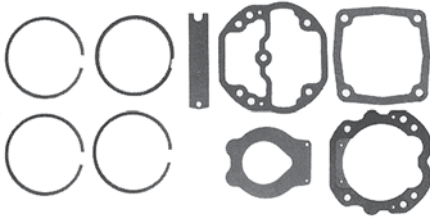

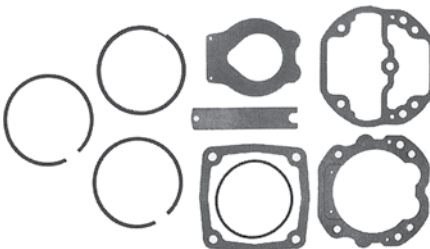

Application	Description	Details	Ref.	Erqo No.						
1 OM 401/402 LA, OM 421/441 + A/LA OM 422/442 +A/LA OM 423/443+ A/LA	<p>EN Crankshaft old version for 90 mm aircooled liner</p> <p>DE Kurbelwelle alte Ausführung, 90 mm luftgekühlte Laufbuchse</p> <p>FR Vilebrequin vieille version pour pour 90 mm air refroidi chemise de cylindre</p> <p>ES Cigüeñal, versión antigua, 90 mm refrigerado por aire</p> <p>PT Virabrequim, versão antiga, 90 mm camisa resfriada ar</p> <p>RU Коленвал Старая версия, 90 мм гильза цилиндра с воздушным охлаждением</p>		403 131 0716	<p>02.19966</p> 						
	<p>EN Crankshaft 100 mm air cooled liner</p> <p>DE Kurbelwelle 100 mm luftgekühlte Laufbuchse</p> <p>FR Vilebrequin 100 mm air refroidi chemise de cylindre</p> <p>ES Cigüeñal 100 mm refrigerado por aire</p> <p>PT Virabrequim 100 mm camisa resfriada a ar</p> <p>RU Коленвал 100 мм гильза с воздушным</p>					442 130 0314	<p>02.19926</p> 			
	<p>EN Bushing 90 mm watercooled + aircooled liner</p> <p>DE Buchse, Kurbelgeh. 90 mm wassergekühlte + luftgekühlte Laufbuchse</p> <p>FR Bague 90 mm refroidi à l'eau + air refroidi chemise de cylindre</p> <p>ES CasquJilo, Cáster del motor, 90 mm Refrigerado por aire y agua</p> <p>PT Bucha, 90 mm camisa resfriada a ar + molhada</p> <p>RU Втулка, Блок-картер 90 мм гильза цилиндра, водяное + воздушное охлаждение</p>								000 131 4250	<p>02.19980</p> 

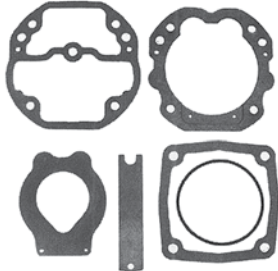
Application	Description	Details	Ref.	Erqo No.
OM 421/422/423, OM 441/442, OM 401/441/442 LA, OM 442 A	<p>EN Bushing 100 mm air cooled liner</p> <p>DE Buchse 100 mm luftgekühlte Laufbuchse</p> <p>FR Bague 100 mm air refroidi chemise de cylindre</p> <p>ES Casquillo 100 mm refrigerado por aire</p> <p>PT Bucha 100 mm camisa resfriada a ar</p> <p>RU Втулка 100 мм гильза с воздушным</p>		442 131 0050	02.19981 
OM 401/402 LA, OM 421/441 + A/LA OM 422/442 + A/LA OM 423/443 + A/LA	<p>EN Flange 90 mm watercooled + aircooled liner</p> <p>DE Flansch 90 mm wassergekühlte + luftgekühlte Laufbuchse</p> <p>FR Palier 90 mm refroidi à l'eau + air refroidi chemise de cylindre</p> <p>ES Brida de apoyo, 90 mm refrigerado por agua y aire</p> <p>PT Flange, 90 mm camisa resfriada a ar + molhada</p> <p>RU Фланец, 90 мм гильза цилиндра водяное + воздушное охлаждение</p>		403 130 1645	02.19952 
OM 422, OM 423 A/LA, OM 442 A/LA, OM 443 A/LA,	<p>EN Flange for 90 mm aircooled liner</p> <p>DE Flansch für 90 mm luftgekühlte Laufbuchse</p> <p>FR Palier pour 90 mm refroidi à l'eau chemise de cylindre</p> <p>ES Brida de apoyo, 90 mm refrigerado por aire</p> <p>PT Flange, 90 mm camisa resfriada a ar</p> <p>RU Фланец, 90 мм гильза цилиндра воздушное охлаждение</p>		422 130 0145	02.19953 
OM 401/421/441 + A/LA, OM 402/422/442 + A/LA, OM 403/423/443 + A/LA -- motor 650332, -- motor 707584, -- motor 793992	<p>EN Roller bearing</p> <p>DE Rollenlager</p> <p>FR Palier à rouleaux</p> <p>ES Rodamiento de rodillos</p> <p>PT Rolamento</p> <p>RU Роликоподшипник</p>		007 981 3001	02.22327 

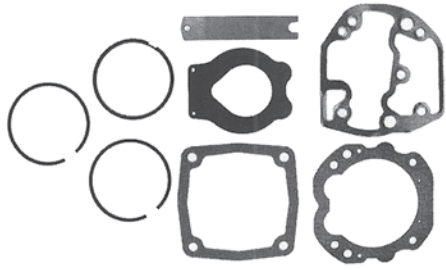

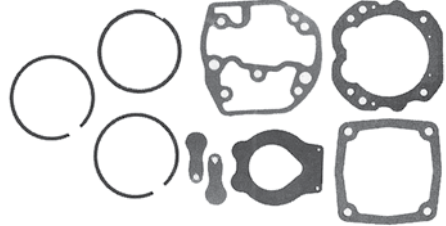

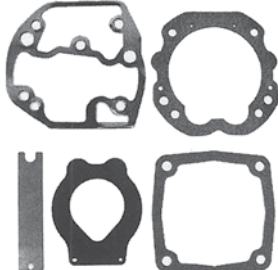



Application	Description	Details	Ref.	Erqo No.
OM 421/422/423, OM 441/442, OM 401/441/442 LA, OM 442 A	<p>EN Flange 100 mm air cooled liner</p> <p>DE Flansch 100 mm luftgekühlte Laufbuchse</p> <p>FR Palier 100 mm air refroidi chemise de cylindre</p> <p>ES Brida de apoyo 100 mm refrigerado por aire</p> <p>PT Flange 100 mm camisa resfriada a ar</p> <p>RU Фланец 100 мм гильза цилиндра, воздушное охлаждение</p>		442 130 0145	02.19954 
OM 401/402 LA, OM 421/441 + A/LA OM 422/442 +A/LA OM 423/443 +A/LA	<p>EN Gear 90 mm watercooled + aircooled liner</p> <p>DE Zahnrad 90 mm wassergekühlte + luftgekühlte Laufbuchse</p> <p>FR Roue dentée 90 mm refroidi à l'eau + air refroidi chemise de cylindre</p> <p>ES Rueda dentada, 90 mm refrigerado por agua + aire</p> <p>PT Engrenagem, 90 mm camisa resfriada a ar + molhada</p> <p>RU Зубчатое колесо 90 мм, водяное + воздушное охлаждение</p>		403 130 0030	02.19948 
OM 421/422/423, OM 441/442, OM 401/441/442 LA, OM 442 A	<p>EN Gear 100 mm air cooled liner</p> <p>DE Zahnrad 100 mm luftgekühlte Laufbuchse</p> <p>FR Roue dentée 100 mm air refroidi chemise de cylindre</p> <p>ES Rueda dentada 100 mm refrigerado por aire</p> <p>PT Engrenagem 100 mm camisa resfriada a ar</p> <p>RU Зубчатое колесо 100 мм гильза с воздушным охлаждением</p>		442 130 0330	02.19949 
OM 401/402/403 + A/LA, OM 421/422/423 + A/LA, OM 441/442/443 + A/LA	<p>EN Bolt</p> <p>DE Bolzen</p> <p>FR Axe</p> <p>ES Bulón</p> <p>PT Parafuso</p> <p>RU Болт</p>		442 990 5401	02.22430 

Application	Description	Details	Ref.	Erqo No.
OM 401/402/403 + A/LA, OM 421/422/423 + A/LA, OM 441/442/443 + A/LA	<p>EN Screw</p> <p>DE Schraube</p> <p>FR Vis</p> <p>ES Tornillo</p> <p>PT Parafuso</p> <p>RU Болт</p>	M 18 x 1,5	403 990 0010	02.22459 
				
OM 401/402/403 + A/LA, OM 421/422/423 + A/LA, OM 441/442/443 + A/LA	<p>EN Cover</p> <p>DE Deckel</p> <p>FR Couvercle</p> <p>ES Tapa</p> <p>PT Tampa</p> <p>RU Крышка</p>		442 131 0021	02.19972 
				
OM 401/402/403, OM 421/422/423, OM 441/442/443	<p>EN Repair kit, compressor Old version, 90 mm watercooled liner</p> <p>DE Reparatursatz, Kompressor Alte Ausführung, 90 mm wassergekühlte Laufbuchse</p> <p>FR Kit de réparation, Compresseur vieille version, 90 mm refroidi à l'eau chemise de cylindre</p> <p>ES Kit de reparación, Compresor versión antigua, 90 mm refrigerado por agua</p> <p>PT Jogo reparo, compressor versão antiga, 90 mm camisa molhada</p> <p>RU Ремонтный комплект, Компрессор старая версия, 90 мм гильза цилиндра, водяное охлаждение</p>		402 130 0320 S1	02.23136 
				
OM 401/402/403, OM 421/422/423, OM 441/442/443	<p>EN Repair kit, compressor 90 mm watercooled + aircooled liner</p> <p>DE Reparatursatz, Kompressor 90 mm wassergekühlte + luftgekühlte Laufbuchse</p> <p>FR Kit de réparation, Compresseur 90 mm refroidi à l'eau + air refroidi chemise de cylindre</p> <p>ES Kit de reparación, Compresor 90 mm camisa refrigerado por agua + aire</p> <p>PT Jogo reparo, compressor 90 mm camisa resfriada a ar + molhada</p> <p>RU Ремонтный комплект 90 мм поршневая гильза с водяным + воздушным охлаждением</p>		402 130 0320 S2	02.23137 
				



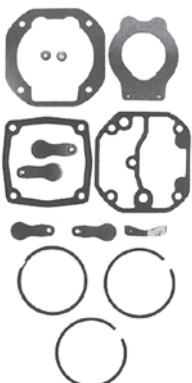

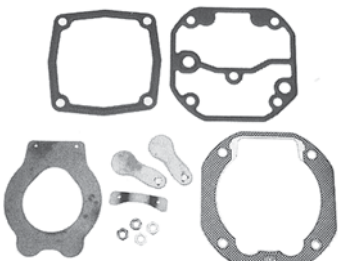
THE ORIGINAL NUMBERS OF THE VEHICLE MANUFACTURER MAY BE USED FOR COMPARISON PURPOSES ONLY AND MUST NOT BE MENTIONED ON INVOICES TO VEHICLE OWNERS.

Application	Description	Details	Ref.	Erqo No.
1 OM 401/402/403, OM 421/422/423, OM 441/442/443	<p>EN Repair kit, compressor 90 mm watercooled liner</p> <p>DE Reparatursatz, Kompressor 90 mm wassergekühlte Laufbuchse</p> <p>FR Kit de réparation, Compresseur 90 mm refroidi à l'eau chemise de cylindre</p> <p>ES Kit de reparación, Compresor, 90 mm refrigerado por agua</p> <p>PT Jogo reparo, compressor, 90 mm camisa molhada</p> <p>RU Ремонтный комплект, Компрессор 90 мм, водяное охлаждение</p>		402 130 0220	02.19943 
OM 401/402 LA, OM 421/441 + A/LA OM 422/442 +A/LA OM 423/443 +A/LA	<p>EN Repair kit, compressor for 90 mm air cooled liner, old version</p> <p>DE Reparatursatz, Kompressor für 90 mm luftgekühlte Laufbuchse, alte Ausführung</p> <p>FR Kit de réparation, Compresseur pour 90 mm air refroidi chemise de cylindre, vieille version</p> <p>ES Kit de reparación, Compresor 90 mm refrigerado por aire, version antigua</p> <p>PT Jogo reparo, compressor 90 mm camisa resfriada a ar, versão antiga</p> <p>RU Ремонтный комплект, Компрессор, старая версия, гильза цилиндра - 90 мм, воздушное охлаждение</p>		447 130 0019 S1	02.23138 
OM 401/402 LA, OM 421/441 + A/LA OM 422/442 + A/LA OM 423/443+A/LA	<p>EN Repair kit, compressor for 90 mm air cooled liner, new version</p> <p>DE Reparatursatz, Kompressor für 90 mm luftgekühlte Laufbuchse, neue Ausführung</p> <p>FR Kit de réparation, Compresseur pour 90 mm air refroidi chemise de cylindre, nouvelle version</p> <p>ES Kit de reparación, Compresor 90 mm refrigerado por aire, version nueva</p> <p>PT Jogo reparo, compressor 90 mm camisa resfriada a ar, versão nova</p> <p>RU Ремонтный комплект, новая версия, гильза цилиндра - 90 мм, воздушное охлаждение</p>		447 130 0019 S2	02.23139 
OM 401/402 LA, OM 421/441 + A/LA OM 422/442 + A/LA OM 423/443+A/LA	<p>EN Repair kit, compressor for 90 mm air cooled liner, old version</p> <p>DE Reparatursatz, Kompressor für 90 mm luftgekühlte Laufbuchse, alte Ausführung</p> <p>FR Kit de réparation, Compresseur pour 90 mm air refroidi chemise de cylindre, vieille version</p> <p>ES Kit de reparación, Compresor 90 mm refrigerado por aire, version antigua</p> <p>PT Jogo reparo, compressor 90 mm camisa resfriada a ar, versão antiga</p> <p>RU Ремонтный комплект, Компрессор, старая версия, гильза цилиндра - 90 мм, воздушное охлаждение</p>		442 130 0020	02.19946 

THE ORIGINAL NUMBERS OF THE VEHICLE MANUFACTURER MAY BE USED FOR COMPARISON PURPOSES ONLY AND MUST NOT BE MENTIONED ON INVOICES TO VEHICLE OWNERS.

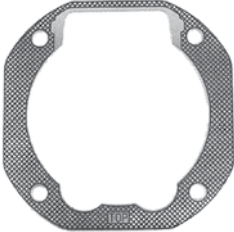

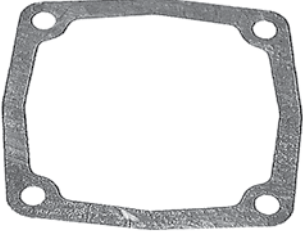







Application	Description	Details	Ref.	Erqo No.
OM 401/402 LA, OM 421/441 + A/LA OM 422/442 + A/LA OM 423/443 + A/LA	<p>EN Repair kit, compressor for 90 mm air cooled liner, new version</p> <p>DE Reparatursatz, Kompressor für 90 mm luftgekühlte Laufbuchse, neue Ausführung</p> <p>FR Kit de réparation, Compresseur pour 90 mm air refroidi chemise de cylindre, vieille version</p> <p>ES Kit de reparación, Compresor 90 mm refrigerado por aire, version nueva</p> <p>PT Jogo reparo, compressor 90 mm camisa resfriada a ar, versão nova</p> <p>RU Ремонтный комплект, новая версия, гильза цилиндра - 90 мм, воздушное охлаждение</p>		442 130 0720 S2	02.23140 
OM 421/422/423, OM 441/442, OM 401/441/442 LA, OM 442 A	<p>EN Repair kit, compressor 100 mm air cooled liner</p> <p>DE Reparatursatz, Kompressor 100 mm luftgekühlte Laufbuchse</p> <p>FR Kit de réparation, Compresseur 100 mm air refroidi chemise de cylindre</p> <p>ES Kit de reparación, Compresor, 100 mm refrigerado por aire</p> <p>PT Jogo reparo, compressor, 100 mm camisa resfriada a ar</p> <p>RU Ремонтный комплект 100 мм, воздушное охлаждение</p>		441 130 0220 S1	02.23141 
OM 421/422/423, OM 441/442, OM 401/441/442 LA, OM 442 A	<p>EN Repair kit, oil scraper ring = 4mm</p> <p>DE Reparatursatz, Ölabstreifring = 4mm</p> <p>FR Kit de réparation, Racleur d'huile = 4mm</p> <p>ES Kit de reparación, Aro rascador de aceite = 4 mm</p> <p>PT Jogo reparo, anel raspador = 4 mm</p> <p>RU Ремонтный комплект, Маслосъемное кольцо = 4 мм</p>		441 130 0220 S4	02.23142 
OM 421/422/423, OM 441/442, OM 401/441/442 LA, OM 442 A	<p>EN Gasket kit</p> <p>DE Dichtungssatz</p> <p>FR Kit de joints</p> <p>ES Juego de juntas</p> <p>PT Jogo junta</p> <p>RU Комплект уплотнителей</p>		441 130 0220 S3	02.23143 

THE ORIGINAL NUMBERS OF THE VEHICLE MANUFACTURER MAY BE USED FOR COMPARISON PURPOSES ONLY AND MUST NOT BE MENTIONED ON INVOICES TO VEHICLE OWNERS.

Application	Description	Details	Ref.	Erqo No.
1 OM 421/422/423, OM 441/442, OM 401/441/442 LA, OM 442 A	<p>EN Gasket kit 100 mm air cooled liner</p> <p>DE Dichtungssatz 100 mm luftgekühlte Laufbuchse</p> <p>FR Kit de joints 100 mm air refroidi chemise de cylindre</p> <p>ES Juego de juntas, 100 mm refrigerado por aire</p> <p>PT Jogo junta, 100 mm camisa resfriada a ar</p> <p>RU Комплект уплотнителей 100 мм гильза цилиндра с воздушным охлаждением</p>		442 994 0060 S	02.23144 
OM 421/422/423, OM 441/442, OM 401/441/442 LA, OM 442 A	<p>EN Gasket 100 mm air cooled liner</p> <p>DE Dichtung 100 mm luftgekühlte Laufbuchse</p> <p>FR Joint 100 mm air refroidi chemise de cylindre</p> <p>ES Empaquetadura, 100 mm refrigerado por aire</p> <p>PT Junta, 100 mm camisa resfriada a ar</p> <p>RU Уплотнение 100 мм гильза цилиндра с воздушным охлаждением</p>		442 131 2880	02.19990 
OM 421/422/423, OM 441/442, OM 401/441/442 LA, OM 442 A	<p>EN Wave leaf spring 100 mm air cooled liner</p> <p>DE Wellblattfeder 100 mm luftgekühlte Laufbuchse</p> <p>FR Ressort à lame 100 mm air refroidi chemise de cylindre</p> <p>ES Ballesta ondulada, 100 mm refrigerado por aire</p> <p>PT Palheta compressor, 100 mm camisa resfriada a ar</p> <p>RU Волнистая листовая рессора гильза цилиндра -100 мм, воздушное охлаждение</p>		442 994 0060	02.22565 
OM 401/402 LA, OM 421/441 + A/LA OM 422/442+A/LA OM 423/443 +A/LA	<p>EN Gasket 90 mm watercooled + aircooled liner</p> <p>DE Dichtung 90 mm wassergekühlte + luftgekühlte Laufbuchse</p> <p>FR Joint 90 mm refroidi à l'eau + air refroidi chemise de cylindre</p> <p>ES Junta, 90 mm refrigerado por agua + por aire</p> <p>PT Junta, 90 mm camisa resfriada a ar + molhada</p> <p>RU Уплотнение 90 мм гильза цилиндра с водяным и воздушным охлаждением</p>		442 131 0080	02.19983 

THE ORIGINAL NUMBERS OF THE VEHICLE MANUFACTURER MAY BE USED FOR COMPARISON PURPOSES ONLY AND MUST NOT BE MENTIONED ON INVOICES TO VEHICLE OWNERS.





Application	Description	Details	Ref.	Erqo No.
OM 401/402/403 + A/LA, OM 421/422/423 + A/LA, OM 441/442/443 + A/LA	<p>EN Gasket 90 + 100 mm air cooled + watercooled liner</p> <p>DE Dichtung 90+ 100 mm luftgekühlte + wassergekühlte Laufbuchse</p> <p>FR Joint 90 + 100 mm air refroidi chemise de cylindre + refroidi à l'eau chemise de cylindre</p> <p>ES Junta, 90 + 100 mm refrigerado por aire y agua</p> <p>PT Junta, 90 + 100 mm camisa resfriada a ar + molhada</p> <p>RU Уплотнение 90 + 100 мм гильза цилиндра, с водяным и воздушным охлаждением</p>		442 131 2480	02.19989 
OM 401/402 LA, OM 421/441 + A/LA OM 422/442 + A/LA OM 423/443 + A/LA	<p>EN Gasket for 90 mm air cooled liner</p> <p>DE Dichtung für 90 mm luftgekühlte Laufbuchse</p> <p>FR Joint pour 90 mm air refroidi chemise de cylindre</p> <p>ES Junta, 90 mm, refrigerado por aire</p> <p>PT Junta, 90 mm camisa resfriada a ar</p> <p>RU Уплотнение для 90 мм гильза цилиндра с воздушным охлаждением</p>		442 131 1980	02.19987 







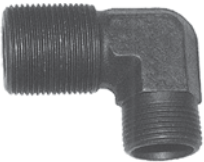

Application	Description	Details	Ref.	Erqo No.
OM 401 LA Euro I, (- motor 650332), OM 441 A + LA, (- motor 650332)	<ul style="list-style-type: none"> EN Suction hose DE Ansaugschlauch FR Tuyau d'aspiration ES Tubo flexible de aspiración PT Mangueira sucção RU Рукав воздухозаборника 		441 134 0082	02.19997 
OM 401 LA Euro I, (motor 650333 -), OM 441 A + LA, (motor 650333 -), OM 441 LA Euro II	<ul style="list-style-type: none"> EN Suction hose DE Ansaugschlauch FR Tuyau d'aspiration ES Tubo flexible de aspiración PT Mangueira sucção RU Рукав воздухозаборника 		441 134 0882	02.19998 
OM401, OM 402, OM 403, OM 421 + A + LA, BM 905-907, (motor 468904-794006), OM 422 (motor 468904-), OM 423 + A + LA, BM 905/907/908, (motor 468904-794006), OM 441 (- motor 794006), OM 442 (- motor 794006)	<ul style="list-style-type: none"> EN Suction hose DE Ansaugschlauch FR Tuyau d'aspiration ES Tubo flexible de aspiración PT Mangueira sucção RU Рукав воздухозаборника 		403 134 0482	02.19995 
OM401.OM 402, OM 403, OM 421 + A + LA, BM 905-907, (- motor 468903), OM 422 (-motor 468903), OM 423 + A + LA, BM 905/907/908, (motor 468904-794006)	<ul style="list-style-type: none"> EN Suction hose DE Ansaugschlauch FR Tuyau d'aspiration ES Tubo flexible de aspiración PT Mangueira sucção RU Рукав воздухозаборника 		403 134 0282	02.19994 
OM 421 + A + LA, BM 905/906, (motor 794007 -), OM 423 + A + LA, BM 905/907/908, (motor 794007 -), OM 441 (motor 794007 -), OM 442 (motor 794007 -)	<ul style="list-style-type: none"> EN Suction hose DE Ansaugschlauch FR Tuyau d'aspiration ES Tubo flexible de aspiración PT Mangueira sucção RU Рукав воздухозаборника 		442 134 0582	02.19999 

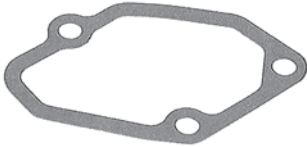
Application	Description	Details	Ref.	Erqo No.
OM 402 LA Euro I, BM 978/982/983, BM 985/986/990 (• motor 707584), OM 442 A + L A	EN Compressor hose DE Kompressorschlauch FR Tuyau compresseur ES Manguera del compresor PT Mangueira compressor RU Шланг компрессора		422 134 0582	02.19996 
OM 402 LA Euro I, BM 978/985/986, BM 990/996(motor 707585 -), OM 442 A + L A	EN Suction hose DE Ansaugschlauch FR Tuyau d'aspiration ES Tubo flexible de aspiración PT Mangueira sucção RU Рукав воздухозаборника		442 134 1282	02.20000 
OM 402 LA Euro I, BM 977/982/983/987 (motor707585--), OM 442 LA	EN Suction hose DE Ansaugschlauch FR Tuyau d'aspiration ES Tubo flexible de aspiración PT Mangueira sucção RU Рукав воздухозаборника		442 134 1382	02.20001 
OM 423 LA, OM 443 A + L A	EN Suction hose DE Ansaugschlauch FR Tuyau d'aspiration ES Tubo flexible de aspiración PT Mangueira sucção RU Рукав воздухозаборника	in roll lengths of 20 m 	496 997 0082	02.22768 
OM 401/421/441 + A/LA, OM 402/422/442 + A/LA, OM 403/423/443 + A/LA	EN Fitting DE Stutzen FR Raccord ES Racor PT Conector RU Патрубок	M 14 x 1,5 / M 16 x 1,5 	403 997 1172	02.22749 

THE ORIGINAL NUMBERS OF THE VEHICLE MANUFACTURER MAY BE USED FOR COMPARISON PURPOSES ONLY AND MUST NOT BE MENTIONED ON INVOICES TO VEHICLE OWNERS.





1

Application	Description	Details	Ref.	Erqo No.
OM 401 / 402/403 + A/LA, OM 421 / 422/423 + A/LA, OM 441 / 442 / 443 + A/LA	(EN) Fitting (DE) Stutzen (FR) Raccord (ES) Racor (PT) Conector (RU) Патрубок	M 16 x 1,5 / M 22 x 1,5	005 997 0172	02.22747 
				
OM 401.923, OM 402, OM 403, OM 423 + A + LA, BM 950, OM 443.940/980	(EN) Elbow (DE) Rohrbogen (FR) Coude (ES) Codo de tubo (PT) Cotovelo (RU) Колено трубы	M 26 x 1,5	327 134 0001	02.19993 
				
OM 401, OM 403, OM 421 +A + LA, OM 422, OM 423 + A + LA, OM 441 LA	(EN) Elbow (DE) Rohrbogen (FR) Coude (ES) Codo de tubo (PT) Cotovelo (RU) Колено трубы	M 26 x 1,5 / M 22 x 1,5	003 990 1671	02.22497 
				

Application	Description	Details	Ref.	Erqo No.
OM 401/402/403, OM 421/422/423, OM 441/442/443 + A/LA	<p>EN Gasket intake manifold</p> <p>DE Dichtung Einlassrohr</p> <p>FR Joint collecteur d'admission</p> <p>ES Junta colector de admisión</p> <p>PT Junta colector de admissão</p> <p>RU Уплотнение Впускная труба</p>		442 141 0780	02.20025 
OM 402 LA, OM 422/442 A/LA	<p>EN Gasket charge air pipe</p> <p>DE Dichtung Ladeluftrohr</p> <p>FR Joint tuyau d'air de charge</p> <p>ES Junta para manguito de aire</p> <p>PT Junta para tubo radiador</p> <p>RU Уплотнение Трубопровод</p>		442 098 0980	02.19914 
OM 401/441 A/LA, OM 402 LA (Euro I), OM 442 LA (BM 442.989/992...), OM 442 LA (BM 446)	<p>EN Gasket air charge pipe</p> <p>DE Dichtung Ladeluftrohr</p> <p>FR Joint tuyau d'air de charge</p> <p>ES Junta para manguito de aire</p> <p>PT Junta para tubo radiador</p> <p>RU Уплотнение Трубопровод</p>		442 141 0980	02.20026 
OM 422/442 A/LA	<p>EN Gasket suction pipe</p> <p>DE Dichtung Saugrohr</p> <p>FR Joint tube d'aspiration</p> <p>ES Junta, manguito de succión manguito de succión</p> <p>PT Junta admissão</p> <p>RU Уплотнение впускной трубы</p>		442 098 1080	02.19915 









THE ORIGINAL NUMBERS OF THE VEHICLE MANUFACTURER MAY BE USED FOR COMPARISON PURPOSES ONLY AND MUST NOT BE MENTIONED ON INVOICES TO VEHICLE OWNERS.

1

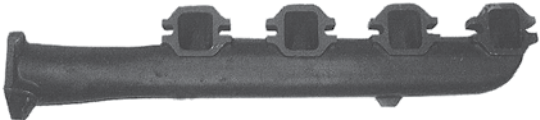

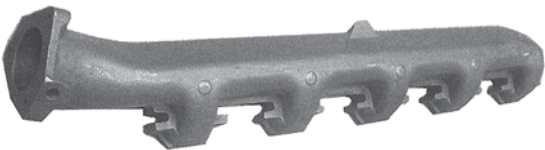







Application	Description	Details	Ref.	Erqo No.
OM 401/421/441 + A/LA, OM 402/422/442 + A/LA, OM 403/423/443 + A/LA	<p>EN Gasket intake manifold</p> <p>DE Dichtung Einlasskrümmer</p> <p>FR Joint collecteur d'admission</p> <p>ES Junta colector de admisión</p> <p>PT Junta colector de admissão</p> <p>RU Уплотнение Впускной коллектор</p>		442 141 1780	<p>02.20030</p> 
OM 441 LA, OM 442 LA	<p>EN Sensor</p> <p>DE Sensor</p> <p>FR Capteur</p> <p>ES Sensor</p> <p>PT Sensor</p> <p>RU Датчик</p>		004 153 0328	<p>02.20072</p> 

Exhaust Manifold





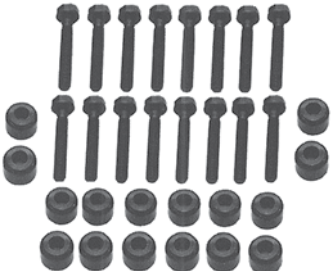

Abgaskrümmer • Collecteur d'Échappement • Colector de Escape
Escape • Выпускной коллектор

Application	Description	Details	Ref.	Erqo No.
OM 402/422/442	<p>EN Exhaust manifold, without throttle left</p> <p>DE Abgaskrümmer, ohne Drosselklappe links</p> <p>FR Collecteur d'échappement, sans vanne d'étranglement gauche</p> <p>ES Colector de escape, sin válvula de estrangulación izquierdo</p> <p>PT Coletor escape, sem freio motor esquerdo</p> <p>RU Выпускной коллектор, без Дроссельная заслонка лев.</p>		402 140 4809	<p>02.20002</p> 
OM 402/422/442	<p>EN Exhaust manifold, without throttle right</p> <p>DE Abgaskrümmer, ohne Drosselklappe rechts</p> <p>FR Collecteur d'échappement, sans vanne d'étranglement droite</p> <p>ES Colector de escape, sin válvula de estrangulación derecho</p> <p>PT Coletor escape, sem freio motor direito</p> <p>RU Выпускной коллектор, без Дроссельная заслонка прав.</p>		402 140 4909	<p>02.20003</p> 
OM 403/423/443	<p>EN Exhaust manifold</p> <p>DE Abgaskrümmer</p> <p>FR Collecteur d'échappement</p> <p>ES Colector de escape</p> <p>PT Coletor escape</p> <p>RU Выпускной коллектор</p>		403 140 4809	<p>02.20004</p> 
OM 403/423/443	<p>EN Exhaust manifold</p> <p>DE Abgaskrümmer</p> <p>FR Collecteur d'échappement</p> <p>ES Colector de escape</p> <p>PT Coletor escape</p> <p>RU Выпускной коллектор</p>		403 140 4909	<p>02.20005</p> 

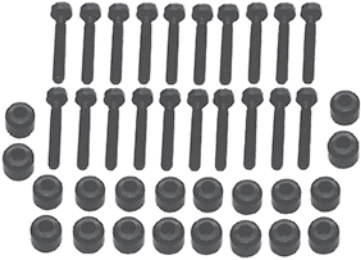

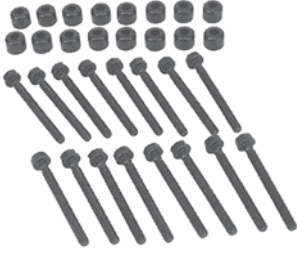







THE ORIGINAL NUMBERS OF THE VEHICLE MANUFACTURER MAY BE USED FOR COMPARISON PURPOSES ONLY AND MUST NOT BE MENTIONED ON INVOICES TO VEHICLE OWNERS.

Application	Description	Details	Ref.	Erqo No.
OM 401/421/441 A/LA	<ul style="list-style-type: none"> EN Exhaust manifold, left DE Abgaskrümmer, links FR Collecteur d'échappement, gauche ES Colector de escape, izquierdo PT Coletor escape, esquerdo RU Выпускной коллектор, лев. 		441 142 0201	02.20031 
OM 401/421/441 A/LA	<ul style="list-style-type: none"> EN Exhaust manifold, right DE Abgaskrümmer, rechts FR Collecteur d'échappement, droite ES Colector de escape, derecho PT Coletor escape, direito RU Выпускной коллектор, прав. 		441 142 0301	02.20032 
OM 401/421/441 + A/LA, OM 402/422/442 + A/LA, OM 403/423/443 + A/LA	<ul style="list-style-type: none"> EN Gasket exhaust manifold DE Dichtung Abgaskrümmer FR Joint collecteur gaz d'échappement ES Junta colector de escape PT Junta colector de escape RU Уплотнение Выпускной коллектор 		403 142 0380	02.20036 
OM 401/421/441 + A/LA	<ul style="list-style-type: none"> EN Mounting kit DE Befestigungssatz FR Jeu de fixations ES Juego de fijación PT Kit fixaçã RU Крепежный комплект 		447 990 6004 S1	02.23145 
OM 402/422/442 + A/LA	<ul style="list-style-type: none"> EN Repair kit DE Reparatursatz FR Kit de réparation ES Kit de reparaci3n PT Kit fixaçã RU Ремонтный комплект 		447 990 5804 S1	02.23146 

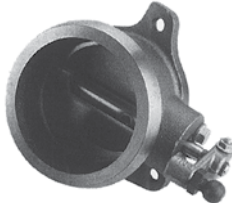
THE ORIGINAL NUMBERS OF THE VEHICLE MANUFACTURER MAY BE USED FOR COMPARISON PURPOSES ONLY AND MUST NOT BE MENTIONED ON INVOICES TO VEHICLE OWNERS.



Application	Description	Details	Ref.	Erqo No.
OM 403/423/443 + A/LA	<ul style="list-style-type: none"> EN Repair kit DE Reparatursatz FR Kit de réparation ES Kit de reparación PT Kit fixação RU Ремонтный комплект 		447 990 5804 S2	02.23147 
OM 402 LA (Euro I), O M 442 LA (BM 442.920...), OM 442 LA (BM 446), OM 442 LA (BM 440)	<ul style="list-style-type: none"> EN Mounting kit DE Befestigungssatz FR Jeu de fixations ES Juego de fijación PT Kit fixação RU Крепежный комплект 		447 990 7104 S	02.23148 
OM 401/421/441 + A/LA, O M 402 LA, OM 422 A/LA, OM 442 A, OM 403/423/443	<ul style="list-style-type: none"> EN Screw DE Schraube FR Vis ES Tornillo PT Parafuso RU Болт 	M 10 x 1,5 x 85	447 990 6004	02.22447 
OM 401 LA (2 x), OM402 (16 x), OM 403 (16/20 x), OM 421 +A+LA (12 x), OM 422 (16 x), OM 423 +A+LA (16x), OM 441 (12 x), OM 441 A+LA (2 x), OM442 (16x), OM 443 +A+LA(16x)	<ul style="list-style-type: none"> EN Screw DE Schraube FR Vis ES Tornillo PT Parafuso RU Болт 	M 10 x 1,5 x 70	447 990 5804	02.22446 
OM401, OM 421+A, OM 441 + LA, OM 402 LA (Euro I), O M 442 LA (BM 442.920...), OM 442 LA (BM 446), OM 442 LA (BM 440), OM 423.950; OM 443.940/980	<ul style="list-style-type: none"> EN Screw DE Schraube FR Vis ES Tornillo PT Parafuso RU Болт 	M 10 x 1,5 x 105	447 990 7104	02.22451 

THE ORIGINAL NUMBERS OF THE VEHICLE MANUFACTURER MAY BE USED FOR COMPARISON PURPOSES ONLY AND MUST NOT BE MENTIONED ON INVOICES TO VEHICLE OWNERS.

Application	Description	Details	Ref.	Erqo No.
OM 401 LA (2 x), OM 402 (16x), OM 403 (16/20 x), OM 421 +A+LA (12 x), OM 422 (1 6 x), OM 423 +A+LA (16 x), OM 441 (12 x), OM 441 A+LA(2x),OM 442 (16 x), OM 443 +A+LA (16 x)	<ul style="list-style-type: none"> EN Washer DE Scheibe FR Rondelle ES Arandela PT Arruela RU Шайба 		007349 010007	02.22866 
OM 401/421/441 + A/LA, OM 402/422/442 + A/LA, OM 403/423/443 + A/LA	<ul style="list-style-type: none"> EN Clamping piece DE Klemmstück FR Agrafe ES Pieza de apriete PT Castanha RU Зажимный элемент 		403 142 0212	02.20033 
OM 402/442 A/LA	<ul style="list-style-type: none"> EN Throttle housing, complete, left DE Drosselklappengehäuse, komplett, links FR Collecteur frein d'échappement, complet, gauche ES Caja de mariposa, completa, izquierda PT Carcaça freio motor, completo, esquerdo RU Корпус дроссельной заслонки, в сборе, левый 		442 140 4953	02.20011 
OM 402/442 A/LA	<ul style="list-style-type: none"> EN Throttle housing, complete, right DE Drosselklappengehäuse, komplett, rechts FR Collecteur frein d'échappement, complet, droite ES Caja de mariposa, completa, derecha PT Carcaça freio motor, completa, direito RU Корпус дроссельной заслонки, в сборе, правый 		442 140 5653	02.20012 
OM 402/442 A/LA	<ul style="list-style-type: none"> EN Throttle housing, complete, right DE Drosselklappengehäuse, komplett, rechts FR Collecteur frein d'échappement, complet, droite ES Caja de mariposa, completa, derecha PT Carcaça freio motor, completa, direito RU Корпус дроссельной заслонки, в сборе, правый 		442 140 5753	02.20013 

Application	Description	Details	Ref.	Erqo No.
OM 422 A/LA, OM 423 LA, OM 443 A/LA	<p>EN Exhaust manifold, with throttle right</p> <p>DE Abgaskrümmer, mit Drosselklappe rechts</p> <p>FR Collecteur d'échappement, avec vanne d'étranglement droite</p> <p>ES Colector de escape, con válvula de estrangulación derecho</p> <p>PT Coletor escape, com freio motor direito</p> <p>RU Выпускной коллектор, с дроссельной заслонкой правый</p>		422 140 5653	02.20008 
OM 422 A/LA, OM 423 LA, OM 443 A/LA	<p>EN Exhaust manifold, with throttle left</p> <p>DE Abgaskrümmer, mit Drosselklappe links</p> <p>FR Collecteur d'échappement, avec vanne d'étranglement gauche</p> <p>ES Colector de escape, con válvula de estrangulación izquierdo</p> <p>PT Coletor escape, com freio motor esquerdo</p> <p>RU Выпускной коллектор, с дроссельной заслонкой левый</p>		422 140 5753	02.20009 
OM 401/421/441 LA	<p>EN Throttle kit, stainless steel</p> <p>DE Drosselklappensatz, Edelstahl</p> <p>FR Kit volet de frein d'échappement, acier inox</p> <p>ES Juego de válvulas de estrangulación, acero inoxidable</p> <p>PT Jogo freio motor, aço inoxidável</p> <p>RU Комплект дроссельных заслонок, Нержавеющая сталь</p>		441 140 0363	02.20018 
OM 401/421/441, OM 402/422/442, OM 403/423/443	<p>EN Throttle kit, stainless steel</p> <p>DE Drosselklappensatz, Edelstahl</p> <p>FR Kit volet de frein d'échappement, acier inox</p> <p>ES Juego de válvulas de estrangulación, acero inoxidable</p> <p>PT Jogo freio motor, aço inoxidável</p> <p>RU Комплект дроссельных заслонок, Нержавеющая сталь</p>		441 140 0463	02.20019 

1

Application	Description	Details	Ref.	Erqo No.
OM 401/421/441, OM 402/422/442, OM 403/423/443	<p>EN Throttle kit, stainless steel</p> <p>DE Drosselklappensatz, Edelstahl</p> <p>FR Kit volet de frein d'échappement, acier inox</p> <p>ES Juego de válvulas de estrangulación, acero inoxidable</p> <p>PT Jogo freio motor, aço inoxidável</p> <p>RU Комплект дроссельных заслонок, Нержавеющая сталь</p>		904 140 0063	02.20020 
OM 421/422/423 A/LA -- motor	<p>EN Throttle kit, stainless steel</p> <p>DE Drosselklappensatz, Edelstahl</p> <p>FR Kit volet de frein d'échappement, acier inox</p> <p>ES Juego de válvulas de estrangulación, acero inoxidable</p> <p>PT Jogo freio motor, aço inoxidável</p> <p>RU Комплект дроссельных заслонок, Нержавеющая сталь</p>		422 140 0963	02.20015 
OM 421/422/423 A/LA motor--, OM 441/442/443 A/LA	<p>EN Throttle kit, stainless steel</p> <p>DE Drosselklappensatz, Edelstahl</p> <p>FR Kit volet de frein d'échappement, acier inox</p> <p>ES Juego de válvulas de estrangulación, acero inoxidable</p> <p>PT Jogo freio motor, aço inoxidável</p> <p>RU Комплект дроссельных заслонок, Нержавеющая сталь</p>		441 140 0263	02.20017 
OM 401/421/441 + A/LA, OM 402/422/442 + A/LA, OM 403/423/443 + A/LA	<p>EN Cylinder</p> <p>DE Zylinder</p> <p>FR Cylindre</p> <p>ES Cilindro</p> <p>PT Cilindro</p> <p>RU Цилиндр</p>		000 430 4826	02.21361 
OM 401/421/441 + A/LA, OM 402/422/442 + A/LA, OM 403/423/443 + A/LA	<p>EN Ball socket</p> <p>DE Kugelpfanne</p> <p>FR Rotule</p> <p>ES Rótula</p> <p>PT Terminal</p> <p>RU Шаровой подпятник</p>		442 991 5022	02.22526 

THE ORIGINAL NUMBERS OF THE VEHICLE MANUFACTURER MAY BE USED FOR COMPARISON PURPOSES ONLY AND MUST NOT BE MENTIONED ON INVOICES TO VEHICLE OWNERS.

Application	Description	Details	Ref.	Erqo No.
OM 401/421/441 + A/LA, OM 402/422/442 + A/LA, OM 403/423/443 + A/LA	EN Ball socket DE Kugelpfanne FR Rotule ES Cazoleta esférica PT Terminal RU Шаровой подпятник	M 8 / Ø 13 mm	403 991 0222	02.22523 
				
NG/MK/SK	EN Ball socket DE Kugelpfanne FR Rotule ES Cazoleta esférica PT Terminal RU Шаровой подпятник	M 8 / Ø 13 mm		02.22523 
				
OM 401/421/441 A/LA, OM 402/422/442 A/LA, OM 403/423/443 A/LA	EN Bolt DE Bolzen FR Axe ES Bulón PT Parafuso RU Болт		442 144 0674	02.20047 
				
OM 401/421/441 + A/LA, OM 402/422/442 + A/LA, OM 403/423/443 + A/LA	EN Bracket DE Halter FR Support ES Sujeción PT Suporte RU Кронштейн		442 144 0140	02.20045 
				
OM 401/421/441 A/LA, OM 402/422/442 A/LA, OM 403/423/443 A/LAO M 401/421/441 + A/LA, OM 402/422/442 + A/LA, OM 403/423/443 + A/LA	EN Lever DE Hebel FR Levier ES Palanca PT Alavanca RU Рычаг		442 144 0335	02.20042 
				

THE ORIGINAL NUMBERS OF THE VEHICLE MANUFACTURER MAY BE USED FOR COMPARISON PURPOSES ONLY AND MUST NOT BE MENTIONED ON INVOICES TO VEHICLE OWNERS.

1







Application	Description	Details	Ref.	Erqo No.
OM 401/421/441 + A/LA, OM 402/422/442 + A/LA, OM 403/423/443 + A/LA	<ul style="list-style-type: none"> EN Ball pivot DE Kugelzapfen FR Tourillon à bille ES Perno esférico PT Pivô RU Сферическая цапфа 		442 991 5215	02.22514 
OM 401/421/441, OM 402/422/442, OM 403/423/443	<ul style="list-style-type: none"> EN Lever old version DE Hebel alte Ausführung FR Levier ancienne version ES Palanca predecesora PT Alavanca eixo freio motor versão antiga da RU Рычаг старая версия 		403 140 0825	02.20006 
OM 401/421/441, OM 402/422/442, OM 403/423/443	<ul style="list-style-type: none"> EN Lever DE Hebel FR Levier ES Palanca PT Alavanca RU Рычаг 		403 144 0835	02.20041 
OM 401/421/441, OM 402/422/442, OM 403/423/443	<ul style="list-style-type: none"> EN Ball pivot DE Kugelzapfen FR Tourillon à bille ES Perno esférico PT Pivô RU Сферическая цапфа 		442 991 5315	02.22515 
OM 401, OM 402, OM 403	<ul style="list-style-type: none"> EN Spring DE Feder FR Ressort ES Muelle PT Mola espiral RU Пружина 		403 993 0810	02.22551 

THE ORIGINAL NUMBERS OF THE VEHICLE MANUFACTURER MAY BE USED FOR COMPARISON PURPOSES ONLY AND MUST NOT BE MENTIONED ON INVOICES TO VEHICLE OWNERS.

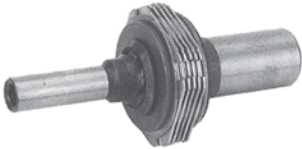
Application	Description	Details	Ref.	Erqo No.
OM 401/402/403 + A/LA, OM 421/422/423 + A/LA, OM 441/442/443 + A/LA	<p>EN Starter motor, 24V 5,4KW</p> <p>DE Anlasser, 24V 5,4KW</p> <p>FR Démarreur, 24V 5,4KW</p> <p>ES Motor de arranque, 24V 5,4KW</p> <p>PT Motor partida, 24V 5,4KW</p> <p>RU Стартер, 24В 5,4кВт</p>	repl. Bosch: 0 001 416 002	004 151 6001	02.20056 
OM 403/423/443 + A/LA, OM 422/442 + A/LA	<p>EN Starter motor, 24V 6.6KW</p> <p>DE Anlasser, 24V 6.6KW</p> <p>FR Démarreur, 24V 6.6KW</p> <p>ES Motor de arranque, 24V 6,6KW</p> <p>PT Motor partida, 24V 6,6KW</p> <p>RU Стартер, 24В 6,6кВт</p>	repl. Bosch: 0 001 417 001	004 151 6101	02.20057 
OM 401/402/403 + A/LA, OM 421/422/423 + A/LA, OM 441/442/443 + A/LA	<p>EN Solenoid switch</p> <p>DE Magnetschalter</p> <p>FR Electrovalve</p> <p>ES Interruptor magnético</p> <p>PT Válvula solenóide do motor partida</p> <p>RU Тяговое реле стартера</p>	repl. Bosch: 0 331 450 001	000 152 4210	02.20067 
OM 401/402/403 + A/LA, OM 421/422/423 + A/LA, OM 441/442/443 + A/LA	<p>EN Solenoid switch</p> <p>DE Magnetschalter</p> <p>FR Electrovalve</p> <p>ES Interruptor magnético</p> <p>PT Válvula solenóide do motor partida</p> <p>RU Тяговое реле стартера</p>	repl. Bosch: 0 331 101 006	000 152 4010	02.20066 
OM 401/402/403 + A/LA, OM 421/422/423 + A/LA, OM 441/442/443 + A/LA	<p>EN Starter pinion, 9 teeth</p> <p>DE Anlasserritzel, 9 Zähne</p> <p>FR Pignon de démarreur, 9 dents</p> <p>ES Piñón del arrancador, 9 Dientes</p> <p>PT Pinhão motor, 9 dentes</p> <p>RU Шестерня стартера, 9 зубья</p>	repl. Bosch: 2 006 382 020	000 151 0613	02.20059 

THE ORIGINAL NUMBERS OF THE VEHICLE MANUFACTURER MAY BE USED FOR COMPARISON PURPOSES ONLY AND MUST NOT BE MENTIONED ON INVOICES TO VEHICLE OWNERS.

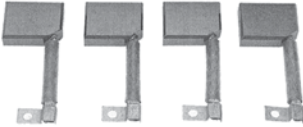
1

Application	Description	Details	Ref.	Erqo No.
OM 401/402/403 + A/LA, OM 421/422/423 + A/LA, OM 441/442/443 + A/LA	<ul style="list-style-type: none"> EN Starter clutch DE Lamellenkupplung FR Valve de démarrage ES Embrague PT Disco embreagem motor de partida RU Многодисковое сцепление 	repl. Bosch: 2 006 401 527	000 151 0633	02.20064 
				
OM 401/402/403 + A/LA, OM 421/422/423 + A/LA, OM 441/442/443 + A/LA	<ul style="list-style-type: none"> EN Starter bushing DE Anlasserbuchse FR Douille de démarreur ES Casquillo PT Bucha motor de partida RU Втулка стартера, Bosch 	repl. Bosch: 2 000 301 016	000 151 4150	02.20065 
				
OM 401/402/403 + A/LA, OM 421/422/423 + A/LA, OM 441/442/443 + A/LA	<ul style="list-style-type: none"> EN Carbon brush set DE Kohlebürstensatz FR Balai d'alternateur ES Juego de escobillas PT Jogo escovas RU Комплект угольных щеток 	repl. Bosch: 2 007 014 070	000 151 8914	02.20063 
				
OM 401/402/403 + A/LA, OM 421/422/423 + A/LA, OM 441/442/443 + A/LA	<ul style="list-style-type: none"> EN Needle bearing DE Nadellager FR Roulement à aiguilles ES Cojinete agujas PT Rolamento caixa RU Игольчатый подшипник 	repl. INA HK 1816	006 981 9010	02.22365 
				

Application	Description	Details	Ref.	Erqo No.
OM 401 LA, OM 421/423, OM 441/443 + A/LA	EN Alternator, 24V 55A DE Generator, 24V 55A FR Alternateur, 24V 55A ES Alternador, 24V 55A PT Alternador, 24V 55A RU Генератор, 24В 55А	repl. Bosch: 0 120 469 518	009 154 0702	02.20076 
				
OM 401/402	EN Alternator, 14V 55A DE Generator, 14V 55A FR Alternateur, 14V 55A ES Alternador, 14V 55A PT Alternador, 14V 55A RU Генератор, 14В 55А	repl. Bosch: 0 120 489 315	007 154 2302	02.20074 
				
OM 441/442 LA	EN Alternator, 24V 80A DE Generator, 24V 80A FR Alternateur, 24V 80A ES Alternador, 24V 80A PT Alternador, 24V 80A RU Генератор, 24В 80А	repl. Bosch: 0 120 468 107	007 154 9202	02.20075 
				
OM 401/402/403 + A/LA, OM 421/422/423 + A/LA, OM 441/442/443 + A/LA	EN Repair kit, alternator DE Reparatursatz, Generator FR Kit de réparation, alternateur ES Juego reparación, Alternador PT Kit reparo, alternador RU Ремонтный комплект, Генератор	repl. Bosch: 1 127 011 143	000 150 1472	02.20052 
				
OM 401/402/403 + A/LA, OM 421/422/423 + A/LA, OM 441/442/443 + A/LA	EN Regulator DE Regler FR Régulateur ES Regulador PT Regulador RU Регулятор	repl. Bosch: 1 197 311 301	000 154 1705	02.20077 
				

THE ORIGINAL NUMBERS OF THE VEHICLE MANUFACTURER MAY BE USED FOR COMPARISON PURPOSES ONLY AND MUST NOT BE MENTIONED ON INVOICES TO VEHICLE OWNERS.

1

Application	Description	Details	Ref.	Erqo No.
OM 401/402/403 + A/LA, OM 421/422/423 + A/LA, OM 441/442/443 + A/LA	<ul style="list-style-type: none"> EN Regulator, 24V DE Regler, 24V FR Régulateur, 24V ES Regulador, 24V PT Regulador, 24V RU Регулятор, 24В 	repl. Bosch: 1 197 311 315	002 154 9606	02.20080



OM 401/402/403 + A/LA, OM 421/422/423 + A/LA, OM 441/442/443 + A/LA	<ul style="list-style-type: none"> EN Carbon brush set, Generator DE Kohlebürstensatz, Generator FR Balais d'alternateur, alternateur ES Escobillas de carbon, Generator PT Jogo escova carvão, alternador RU Комплект угольных щеток, Генератор 	repl. Bosch: 1 127 014 022	000 154 8114	02.20082
---	--	----------------------------	--------------	-----------------



OM 401/421/441 + A/LA, OM 402/422/442 + A/LA, OM 403/423/443 + A/LA	<ul style="list-style-type: none"> EN Ball bearing DE Kugellager FR Roulement à billes ES Rodamiento de bolas PT Rolamento RU Шариковый подшипник 	17 x 52 x 21 mm	007 981 6625	02.22397
---	---	-----------------	--------------	-----------------

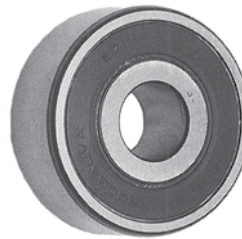



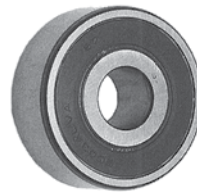



OM 401/421/441 + A/LA, OM 402/422/442 + A/LA, OM 403/423/443 + A/LA	<ul style="list-style-type: none"> EN Ball bearing DE Kugellager FR Roulement à billes ES Rodamiento bolas PT Rolamento RU Шариковый подшипник 	12 x 32 x 14 mm	008 981 1225	02.22398
---	--	-----------------	--------------	-----------------

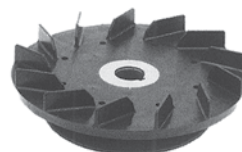

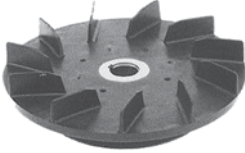







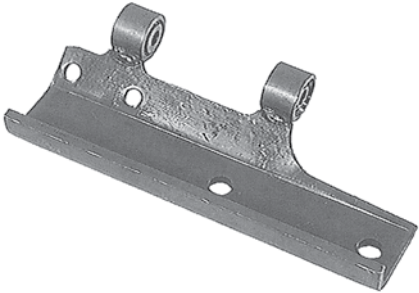

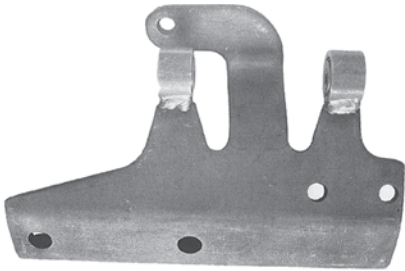

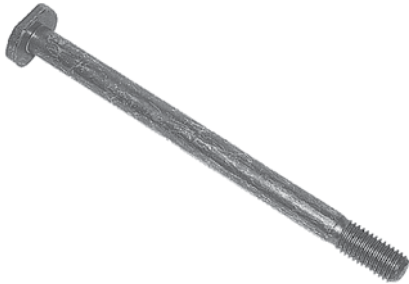

Sample

OM 401/402/403, OM 421/422/423, OM 442	<ul style="list-style-type: none"> EN Pulley 1-groove DE Riemenscheibe einrillig FR Poulie à courroie 1 rainure ES Polea de transmisión 1 estría PT Polla 1 pista RU Ременный шкив одноручейный 		000 155 6318	02.20086
--	---	--	--------------	-----------------



Application	Description	Details	Ref.	Erqo No.
OM 401/421/441 + A/LA, OM 402/422/442 + A/LA, OM 403/423/443 + A/LA -- motor 712354	<p>EN Pulley 1 -groove</p> <p>DE Riemenscheibe einrillig</p> <p>FR Poulie à courroie 1 rainure</p> <p>ES Polea de transmisión 1 estría</p> <p>PT Polia 1 pista</p> <p>RU Ременный шкив одноручейный</p>		000 155 7118	02.20087 
OM 401/402 LA, OM 441/442/443 + A/LA motor 712355 --	<p>EN Pulley</p> <p>DE Riemenscheibe</p> <p>FR Poulie</p> <p>ES Polea de transmisión</p> <p>PT Polia</p> <p>RU Ременный шкив</p>		442 155 0615	02.20085 
OM 401 LA, OM 402 LA, OM 441 + LA, OM 442 + A/LA, OM 443 + A motor 712355 --	<p>EN Fan, starter</p> <p>DE Lüfter, Generator</p> <p>FR Ventilateur, démarreur</p> <p>ES Ventilador, arranque</p> <p>PT Hélice, motor partida</p> <p>RU Вентилятор, Генератор</p>	repl. Bosch: 1 126 610 065	000 155 8518	02.20089 
OM 401/402/403, OM 422 --motor 001057	<p>EN Generator bracket</p> <p>DE Generatorträger</p> <p>FR Support de générateur</p> <p>ES Soporte del generador</p> <p>PT Suporte alternador</p> <p>RU Кронштейн генератора</p>		403 150 3270	02.20049 









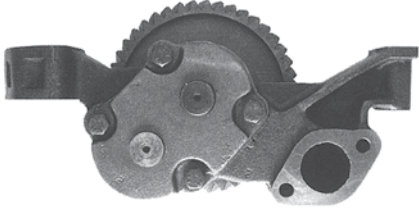

Application	Description	Details	Ref.	Erqo No.
OM 401/402/403, OM 421/422/423 motor 001058-130032	<ul style="list-style-type: none"> EN Carrier DE Träger FR Support ES Soporte PT Suporte RU Кронштейн 		403 150 4270	02.20050 
OM 421/422/423 motor 130033--; OM 401/402 LA, OM 441/442/443 + A/LA	<ul style="list-style-type: none"> EN Support DE Träger FR Support ES Soporte PT Suporte RU Кронштейн 		422 150 2070	02.20051 
OM 401/402/403 + A/LA, OM 421/422/423 + A/LA, OM 441/442/443 + A/LA	<ul style="list-style-type: none"> EN Screw DE Schraube FR Vis ES Tornillo PT Parafuso RU Болт 	M 10 x 144 mm 	352 155 0171	02.20096 
OM 401/421/441 +A/LA, OM 402/422/442 +A/LA, OM 403/423/443 +A/LA	<ul style="list-style-type: none"> EN Repair kit DE Reparatursatz FR Kit de réparation ES Kit de reparación PT Jogo reparo RU Ремонтный комплект 		403 150 0572 S1	02.23149 
OM 421.909, OM 422.916	<ul style="list-style-type: none"> EN Repair kit DE Reparatursatz FR Kit de réparation ES Kit de reparación PT Jogo reparo RU Ремонтный комплект 		352 150 2472 S1	02.23150 

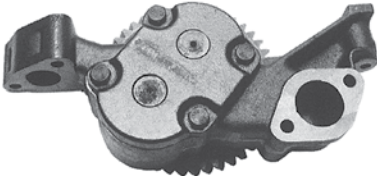
Application	Description	Details	Ref.	Erqo No.
OM 401/421/441 +A/LA, OM 402/422/442 +A/LA, OM 403/423/443 +A/LA	EN Clamping screw DE Spannschraube FR Vis de serrage ES Tornillo de sujeción PT Parafuso olhai RU Натяжной болт		403 150 0572	02.20054 
OM 421.909, OM 422.916	EN Clamping screw DE Spannschraube FR Vis de serrage ES Tornillo de sujeción PT Parafuso olhai RU Натяжной болт		352 150 2472	02.20053 
OM 401/421/441 + A/LA, OM 402/422/442 + A/LA, OM 403/423/443 + A/LA	EN Clamping piece DE Klemmstück FR Agrafe ES Pieza de apriete PT Abraçadeira RU Зажимный элемент		364 155 0028	02.20092 
OM 401/402/403 + A/LA, OM 421/422/423 + A/LA, OM 441/442/443 + A/LA	EN Tension nut DE Spannmutter FR Ecrou ES Tuerca de apriete PT Porca RU Натяжная гайка		352 155 0272	02.20098 
OM 401/421/441 + ALA, OM 402/422/442 + ALA, OM 403/423/443 + A/LA	EN Bushing, alternator bracket DE Buchse, Generatorhalter FR Bague, support alternateur ES Casquillo, Soporte de alternador PT Vucha, suporte alternador RU Втулка, Кронштейн генератора		352 155 0650	02.20094 
M 401/421/441 + A/LA, OM 402/422/442 + A/LA, OM 403/423/443 + A/LA	EN Bushing, alternator bracket DE Buchse, Generatorhalter FR Bague, support alternateur ES Casquillo, Soporte de alternador PT Vucha, suporte alternador RU Втулка, Кронштейн генератора		403 155 0250	02.20095 

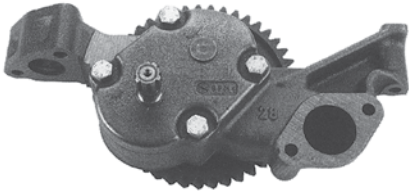
THE ORIGINAL NUMBERS OF THE VEHICLE MANUFACTURER MAY BE USED FOR COMPARISON PURPOSES ONLY AND MUST NOT BE MENTIONED ON INVOICES TO VEHICLE OWNERS.

1

Application	Description	Details	Ref.	Erqo No.
OM 441/442 LA, BM 381/383/385/387, 389/393/395 BM 616/617/619/620, 621/622/623/624, 625/645/646/647, 648/649/652/653, 654/655/656/657, 658/659	<ul style="list-style-type: none"> EN Start switch DE Startschalter FR Interrupteur de démarrage ES Interruptor de arranque PT Botão partida RU Выключатель стартера 		003 545 2314	<p>02.22002</p> 

Application	Description	Details	Ref.	Erqo No.
OM 401/402 LA, OM 403, OM 421/422, OM 441 A/LA, OM 442 --motor 121799	<ul style="list-style-type: none"> EN Oil pump DE Ölpumpe FR Pompe à huile ES Bomba de aceite PT Bomba óleo RU Масляный насос 		403 180 1701	02.20099 
OM 402 LA, OM 403, OM 423, OM 442 + A/LA, OM 443 motor 121800--	<ul style="list-style-type: none"> EN Oil pump DE Ölpumpe FR Pompe à huile ES Bomba de aceite PT Bomba óleo RU Масляный насос 		423 180 2501	02.20104 
OM 422/423 A/LA motor 003747--	<ul style="list-style-type: none"> EN Oil pump DE Ölpumpe FR Pompe à huile ES Bomba de aceite PT Bomba óleo RU Масляный насос 		403 180 2501	02.20100 
OM 422/423 A/LA motor 003747--	<ul style="list-style-type: none"> EN Oil pump without drive gear DE Ölpumpe ohne Antriebsrad FR Pompe à huile sans roue d'entraînement ES Bomba de aceite sin rueda motriz PT Bomba óleo sem engrenagem RU Масляный насос без Ведущая шестерня 		403 180 3001	02.20101 
OM 401/421/441 + A/LA, OM 402/422/442 + A/LA, OM 403/423/443 + A/LA	<ul style="list-style-type: none"> EN Gasket, oil pump DE Dichtung, Ölpumpe FR Joint, pompe à huile ES Junta, bomba de aceite PT Junta, bomba óleo RU Уплотнение, Масляный насос 		917003 036003	02.23019 

THE ORIGINAL NUMBERS OF THE VEHICLE MANUFACTURER MAY BE USED FOR COMPARISON PURPOSES ONLY AND MUST NOT BE MENTIONED ON INVOICES TO VEHICLE OWNERS.

Application	Description	Details	Ref.	Erqo No.
OM 401/421/441 + A/LA, OM 402/422/442 + A/LA, OM 403/423/443 + A/LA	<p>EN Overflow valve</p> <p>DE Überströmventil</p> <p>FR Valve de sécurité</p> <p>ES Válvula de sobrepresión</p> <p>PT Válvula alívio</p> <p>RU Перепускной клапан</p>		541 180 0715	02.20113 

OM 401/421/441 + A/LA, OM 402/422/442 + A/LA, OM 403/423/443 + A/LA	<p>EN Overflow valve</p> <p>DE Überströmventil</p> <p>FR Valve de sécurité</p> <p>ES Válvula de sobrepresión</p> <p>PT Válvula alívio</p> <p>RU Предохранительный клапан</p>		442 180 0015	02.20112 
--	--	---	--------------	---

OM 401/421/441 + A/LA, OM 402/422/442 + A/LA, OM 403/423/443 + A/LA	<p>EN Cap for overflow valve</p> <p>DE Kappe für Überströmventil</p> <p>FR Bouchon pour valve de sécurité</p> <p>ES Caperuza para válvula de descarga</p> <p>PT Capa para válvula alívio</p> <p>RU Колпачок на перепускной клапан</p>		404 988 5235	02.22410 
--	---	--	--------------	---

OM 402 LA, OM 422 A + LA, BM 954-959, (motor 003746 -), OM 442 A BM 940-953	<p>EN Suction pipe</p> <p>DE Saugrohr</p> <p>FR Collecteur d'admission</p> <p>ES Tubo de admisión</p> <p>PT Tubo sucção bomba</p> <p>RU Впускной коллектор</p>		422 180 3252	02.20127 
--	--	--	--------------	---

Oil Pump

Ölpumpe • Pompe à huile • Bomba de Aceite
Bomba de Óleo • Масляный насос

Application	Description	Details	Ref.	Erqo No.
OM 442 LA	EN Suction pipe DE Saugrohr FR Collecteur d'admission ES Tubo de admisión PT Tubo sucção bomba RU Впускной коллектор		442 180 1252	02.20128





Sample



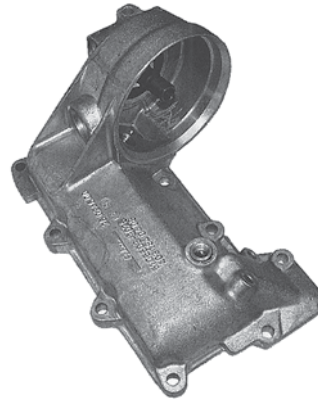

1

Application	Description	Details	Ref.	Erqo No.
OM 401/402/403 --motor 129660	<ul style="list-style-type: none"> EN Oil cooler cover DE Ölkühlerdeckel FR Bouchon refroidisseur d'huile ES Tapón del refrigerador de aceite PT Tampa radiador óleo RU Крышка масляного радиатора 		403 180 1438	02.20120 



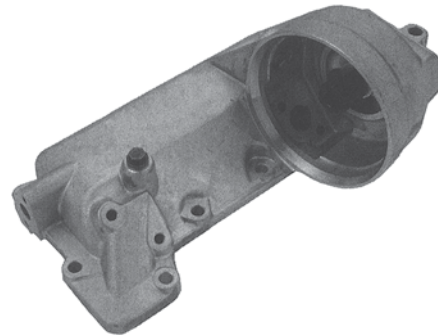





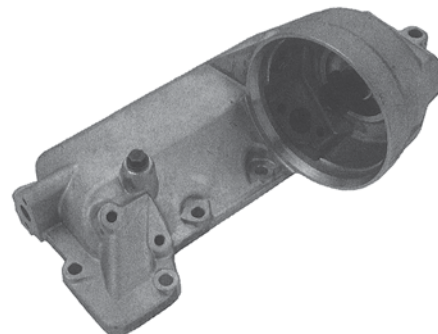

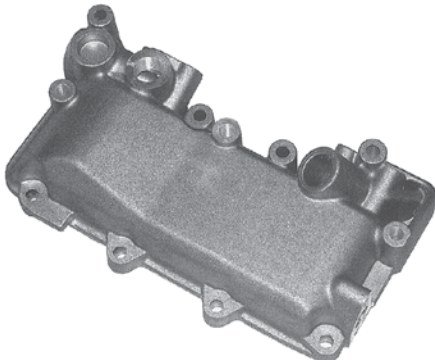
OM 401/402/403 motor 129661 --; OM 421/422/423 --motor 139199	<ul style="list-style-type: none"> EN Oil cooler housing DE Ölkühlergehäuse FR Carter refroidisseur d'huile ES Carcasa del refrigerador de aceite PT Tampa radiador óleo RU Корпус масляного радиатора 		403 180 2438	02.20121 
--	--	--	--------------	--

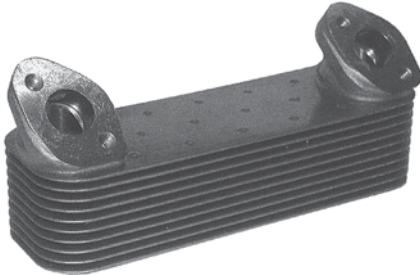

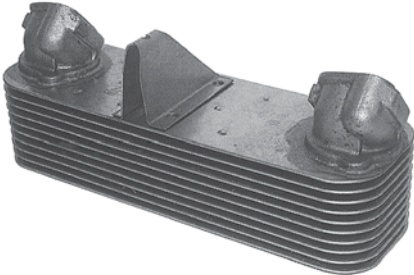

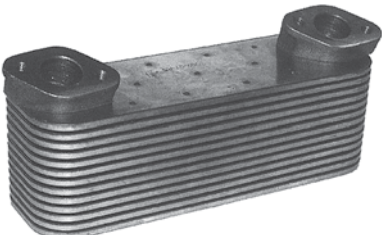





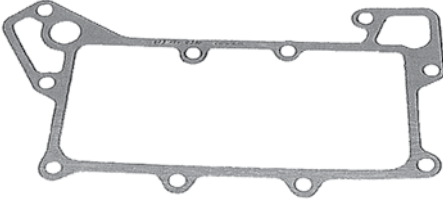

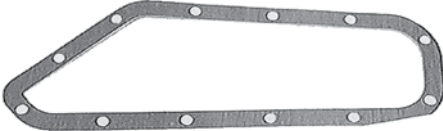
OM 401/402 LA; OM 421/422/423 motor 139200--; OM 421/422/423 A/LA, OM 441/442/443 + A/LA	<ul style="list-style-type: none"> EN Oil cooler housing DE Ölkühlergehäuse FR Carter refroidisseur d'huile ES Carcasa del refrigerador de aceite PT Tampa radiador óleo RU Корпус масляного радиатора 		403 180 3938	02.20122 
--	--	--	--------------	---



Application	Description	Details	Ref.	Erqo No.
OM 401, OM 402 LA, OM 441 + LA, OM 442 + A/LA	<ul style="list-style-type: none"> EN Oil cooler housing DE Ölkühlergehäuse FR Carter refroidisseur d'huile ES Carcasa del refrigerador de aceite PT Tampa radiador óleo RU Корпус масляного радиатора 		457 188 0504	02.20154 
OM 401/421/441 + A/LA, OM 402/422/442 + A/LA, OM 403/423/443 + A/LA	<ul style="list-style-type: none"> EN Oil cooler DE Ölkühler FR Refroidisseur d'huile ES Refrigerador de aceite PT Radiador óleo RU Масляный радиатор 		001 188 3101	02.20143 
OM 401/421/441 + A/LA, OM 402/422/442 + A/LA, OM 403/423/443 + A/LA	<ul style="list-style-type: none"> EN Oil cooler DE Ölkühler FR Refroidisseur d'huile ES Refrigerador de aceite PT Radiador óleo RU Масляный радиатор 		001 188 8801	02.20146 
OM 401/402 LA, OM 441/442 A+LA	<ul style="list-style-type: none"> EN Oil cooler DE Ölkühler FR Refroidisseur d'huile ES Refrigerador de aceite PT Radiador óleo RU Масляный радиатор 		002 188 7901	02.20149 

THE ORIGINAL NUMBERS OF THE VEHICLE MANUFACTURER MAY BE USED FOR COMPARISON PURPOSES ONLY AND MUST NOT BE MENTIONED ON INVOICES TO VEHICLE OWNERS.



Application	Description	Details	Ref.	Erqo No.
OM 422 A/LA (BM951-959), OM 423 LA (BM 423.950) --motor	<ul style="list-style-type: none"> EN Oil cooler DE Ölkühler FR Refroidisseur d'huile ES Refrigerador de aceite PT Radiador óleo RU Масляный радиатор 		422 188 0001	02.20150 
OM 422 A/LA (BM951-959), OM 423 LA (BM 423.950) --motor	<ul style="list-style-type: none"> EN Oil cooler DE Ölkühler FR Refroidisseur d'huile ES Refrigerador de aceite PT Radiador óleo RU Масляный радиатор 		422 188 0101	02.20151 
OM 401/402/403 --motor 129660	<ul style="list-style-type: none"> EN Gasket, oil cooler DE Dichtung, Ölkühler FR Joint, Radiateur d'huile ES Junta, Refrigerador de aceite PT Junta, resfriador óleo RU Уплотнение, Масляный радиатор 		442 184 0580	02.20133 
OM 401/402/403 motor 129661-- OM 401/402/403 A/LA, OM 421/422/423 + A/LA, OM 441/442/443 + A/LA	<ul style="list-style-type: none"> EN Gasket, Oil cooler DE Dichtung, Ölkühler FR Joint, Radiateur d'huile ES Junta, Refrigerador de aceite PT Junta, resfriador óleo RU Уплотнение, Масляный радиатор 		442 188 0580	02.20156 
OM 422 A/LA (BM 951-959), OM 423 LA (BM 423.950) --motor	<ul style="list-style-type: none"> EN Gasket DE Dichtung FR Joint ES Junta PT Junta RU Уплотнение 		442 188 0480	02.20155 
OM 401/421/441 + A/LA, OM 402/422/442 + A/LA, OM 403/423/443 + A/LA	<ul style="list-style-type: none"> EN Gasket DE Dichtung FR Joint ES Junta PT Junta RU Уплотнение 		917003 026003	02.23018 

Application	Description	Details	Ref.	Erqo No.
OM 401/421/441 + A/LA, OM 402/422/442 + A/LA, OM 403/423/443 + A/LA	EN Gasket DE Dichtung FR Joint ES Junta PT Junta RU Уплотнение		917003 022003	02.23017 
OM 401/421/441 + A/LA, OM 402/422/442 + A/LA, OM 403/423/443 + A/LA	EN Repair kit, valve DE Reparatursatz, Ventil FR Kit de réparation, Soupape ES Kit de reparación, Válvula PT Jogo reparo, válvula RU Ремонтный комплект, Клапан		403 184 0132 S2	02.23151 
OM 401/421/441 + A/LA, OM 402/422/442 + A/LA, OM 403/423/443 + A/LA	EN Repair kit DE Reparatursatz FR Kit de réparation ES Kit de reparación PT Jogo reparo RU Ремонтный комплект		403 184 0132 S1	02.23152 
OM 401/421/441 + A/LA, OM 402/422/442 + A/LA, OM 403/423/443 + A/LA	EN Valve DE Ventil FR Soupape ES Válvula PT Válvula RU Клапан		403 184 0132	02.20131 
OM 401 /402/403 + A/LA, OM 421 /422/423 + A/LA, OM 441 /442/443 + A/LA	EN Drain plug, with magnet DE Verschlusschraube, mit Magnet FR Bouchon de vidange, avec aimant ES Tapón roscado, con imán PT Vujão, magnético RU Резьбовая пробка, с магнитом	M 26 x 1,5 	403 997 0032	02.22604 
OM 401/421/441 + A/LA, OM 402/422/442 + A/LA, OM 403/423/443 + A/LA	EN Drain plug DE Verschlusschraube FR Bouchon de vidange ES Tapón roscado PT Vujão RU Резьбовая пробка	M 14 x 1,5 	007604 014110	02.22883 



NG/MK/SK

THE ORIGINAL NUMBERS OF THE VEHICLE MANUFACTURER MAY BE USED FOR COMPARISON PURPOSES ONLY AND MUST NOT BE MENTIONED ON INVOICES TO VEHICLE OWNERS.

1

Application	Description	Details	Ref.	Erqo No.
OM 401 LA Euro I, OM 402 LA Euro I, OM 441 + LA, OM 442 + LA (motor 789374--) V 730, 731, 733 H 740, 741, 742, 744, 745, 746, 748 GM 710/717	<ul style="list-style-type: none"> EN Drain plug DE Verschlusschraube FR Bouchon de vidange ES Tapón roscado PT Bujão RU Резьбовая пробка 		432 997 0032	02.22597 

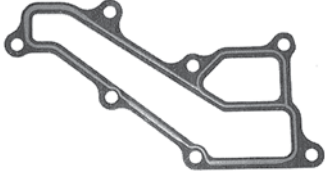
OM 401/402 LA, OM 421/422/423 + A/LA, OM 441/442/443 + A/LA	<ul style="list-style-type: none"> EN Filter housing DE Filtergehäuse FR Carter de filtre ES Carcasa del Filtro PT Carcaça filtro RU Корпус фильтра 		403 180 0011	02.20110 
---	---	---	--------------	---

OM 401/402 LA, OM 441/442+A/LA	<ul style="list-style-type: none"> EN Gasket DE Dichtung FR Joint ES Junta PT Junta para RU Уплотнение 		442 184 0480	02.20132 
-----------------------------------	--	--	--------------	---

OM 401/421/441 + A/LA, OM 402/422/442 + A/LA, OM 403/423/443 + A/LA	<ul style="list-style-type: none"> EN Oil filter kit DE Ölfiltersatz FR Jeu de filtres huile ES Juego para filtro de aceite PT Jogo filtro óleo RU Комплект масляного фильтра 		402 180 0009	02.20106 
--	---	--	--------------	---

THE ORIGINAL NUMBERS OF THE VEHICLE MANUFACTURER MAY BE USED FOR COMPARISON PURPOSES ONLY AND MUST NOT BE MENTIONED ON INVOICES TO VEHICLE OWNERS.

Application	Description	Details	Ref.	Erqo No.
OM 401/402, OM 421.905-910, OM 422.906-923, OM 441.920/950/953, OM 442.905-919, OM 442.925-935	<p>EN Oil filter kit</p> <p>DE Ölfiltersatz</p> <p>FR Kit filtre à huile</p> <p>ES Juego para filtro de aceite</p> <p>PT Jogo filtro óleo</p> <p>RU Комплект масляного фильтра</p>	repl. M+H: H 1275 X	401 180 0009	02.20105 

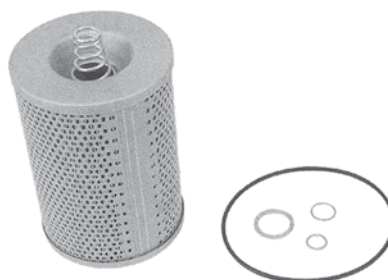

OM 401/402 LA, OM 441/442 + A/LA	<p>EN Oil filter kit for vehicles with double oil filter</p> <p>DE Ölfiltersatz für Fahrzeuge mit doppeltem Ölfilter</p> <p>FR Jeu de filtres à huile pour véhicules avec filtre à huile double</p> <p>ES Juego para filtro de aceite para vehículos con doble filtro de aceite</p> <p>PT Jogo filtro óleo para veículos com filtro de oleo duplo</p> <p>RU Комплект масляного фильтра для автомобилей с двойным масляным фильтром</p>		441 180 0109	02.20107 
--	--	--	--------------	---



OM 401/421/441 + A/LA, OM 402/422/442 + A/LA, OM 403/423/443 + A/LA	<p>EN O-ring</p> <p>DE O-Ring</p> <p>FR Joint torique</p> <p>ES Junta tórica</p> <p>PT Anel</p> <p>RU Уплотнительное кольцо</p>	134,0 x 4,0	008 997 7045	02.22625 
--	---	-------------	--------------	---

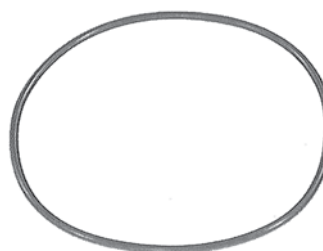

OM 401/402 LA, OM 441/442 + A/LA	<p>EN O-ring</p> <p>DE O-Ring</p> <p>FR Joint torique</p> <p>ES Junta tórica</p> <p>PT Anel</p> <p>RU Уплотнительное кольцо</p>	94,0 x 3,5	016 997 0748	02.22722 
--	---	------------	--------------	---



1

Application	Description	Details	Ref.	Erqo No.
OM 401/421/441 + A/LA, OM 402/422/442 + A/LA, OM 403/423/443 + A/LA motor 129661--	(EN) Screw, filter housing (DE) Schraube, Filtergehäuse (FR) Vis, Boîtier de filtre (ES) Tornillo, Carcasa del filtro (PT) Parafuso, carcaça filtro óleo (RU) Болт, Корпус фильтра		403 990 0901	02.22426 

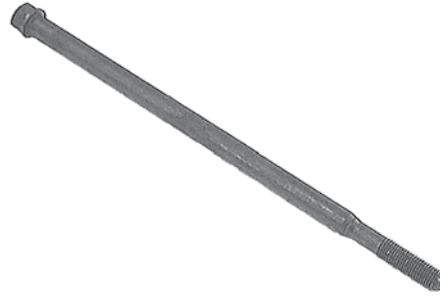

OM 401/402 LA, OM 421/422/423 + A/LA, OM 441/442/443 + A/LA	(EN) Drain plug (DE) Verschlusschraube (FR) Bouchon de vidange (ES) Tapón roscado (PT) Bujão (RU) Резьбовая пробка	M 18 x 1,5	442 997 0030	02.22595 
---	---	------------	--------------	---











OM 401 LA, OM 402 LA, OM 441 + LA, OM 442 + A/LA	(EN) O-ring (DE) O-Ring (FR) Joint torique (ES) Junta tórica (PT) Anel (RU) Уплотнительное кольцо	39,2 x 3,0 mm	018 997 1148	02.22725 
---	--	---------------	--------------	---









OM 401 LA, OM 402 LA, OM 441 + LA, OM 442 + A/LA	(EN) O-ring (DE) O-Ring (FR) Joint torique (ES) Junta tórica (PT) Anel (RU) Уплотнительное кольцо	26,2 x 3,0 mm	018 997 1248	02.22726 
---	--	---------------	--------------	---

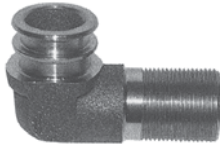

Application	Description	Details	Ref.	Erqo No.
OM 402 LA, OM 442 A + L A	<ul style="list-style-type: none"> EN Oil line right DE Ölleitung rechts FR Tuyau d'huile droite ES Tubería de aceite derecha PT Tubo óleo direito RU Маслопровод прав. 		442 180 1720	02.23153 
OM 402 LA, OM 422 A + LA, OM 442 A + L A	<ul style="list-style-type: none"> EN Oil line left DE Ölleitung links FR Tuyau d'huile gauche ES Tubería de aceite izquierdo PT Tubo óleo esquerdo RU Маслопровод лев. 		422 180 0320	02.23154 
OM 422 A + LA, OM 442 A	<ul style="list-style-type: none"> EN Oil line right DE Ölleitung rechts FR Tuyau d'huile droite ES Tubería de aceite derecha PT Tubo óleo direito RU Маслопровод прав. 		442 180 2220	02.23155 
OM 423 LA, OM 443 LA	<ul style="list-style-type: none"> EN Oil line left DE Ölleitung links FR Tuyau d'huile gauche ES Tubería de aceite izquierda PT Tubo óleo esquerdo RU Маслопровод лев. 		423 180 0820	02.23156 

THE ORIGINAL NUMBERS OF THE VEHICLE MANUFACTURER MAY BE USED FOR COMPARISON PURPOSES ONLY AND MUST NOT BE MENTIONED ON INVOICES TO VEHICLE OWNERS.

Application	Description	Details	Ref.	Erqo No.
OM 423 A + LA, OM 443 A + LA	(EN) Oil line right (DE) Ölleitung rechts (FR) Tuyau d'huile droite (ES) Tubería de aceite derecha (PT) Tubo óleo direito (RU) Маслопровод прав.		423 180 0920	02.20117 
OM 401/421/441 + A/LA, OM 402/422/442 + A/LA, OM 403/423/443 + A/LA	(EN) Hollow screw (DE) Hohlschraube (FR) Vis banjo (ES) Perno hueco (PT) Parafuso vazado (RU) Пустотельный болт	M 14 x 1,5	364 990 0063	02.22484 
OM 402 LA Euro I, OM 422 / 442 A + LA, OM 443 A	(EN) Hollow screw (DE) Hohlschraubstutzen (FR) Vis banjo (ES) Racor para perno hueco (PT) Parafuso vazado (RU) Пустотелая горловина	M 14 x 1,5 / M 16 x 1,5	915037 010100	02.22984 
OM 401 / 402 LA, OM 421 / 422/423 A + LA, OM 441 / 442 A + LA	(EN) Oil line (DE) Ölleitung (FR) Tuyau d'huile (ES) Tubería de aceite (PT) Tubo óleo (RU) Маслопровод		422 187 0801	02.20134 
OM 401/402/403 + A/LA, OM 421/422/423 + A/LA, OM 441/442/443 + A/LA	(EN) Oil seal (DE) Wellendichtring (FR) Joint speed (ES) Anillo retén (PT) Retentor (RU) Сальник	22,9 x 31,5 x 5,9	422 997 0040	02.22620 

Application	Description	Details	Ref.	Erqo No.
OM 401 LA, OM 421 A + LA, OM 422 A + LA, OM 423 A + LA, OM 441 A + LA, OM 443 A + LA	<ul style="list-style-type: none"> EN Connector DE Stutzen FR Raccord ES Racor PT Conexão RU Патрубок 		422 997 0272	02.22750 
OM 402 LA, OM 422 A + LA, OM 423 A + LA, OM 442 A + LA, OM 443 A + LA	<ul style="list-style-type: none"> EN Pipe bend, left DE Rohrkrümmer, links FR Tube collecteur, gauche ES Codo, izquierdo PT Cano retorno óleo, esquerdo RU Колено трубы, лев. 		422 187 0324	02.20135 
OM 402 LA, OM 422 A + LA, OM 442 A + LA	<ul style="list-style-type: none"> EN Pipe bend, right DE Rohrkrümmer, rechts FR Tube collecteur, droite ES Codo, derecho PT Cano retorno óleo, direito RU Колено трубы, прав. 		442 187 0624	02.20136 

Application	Description	Details	Ref.	Erqo No.
OM 401/402/403 --motor 129660	<ul style="list-style-type: none"> EN Water pump DE Wasserpumpe FR Pompe à eau ES Bomba de agua PT Bomba d'agua RU Водяной насос 		403 200 7001	02.20163

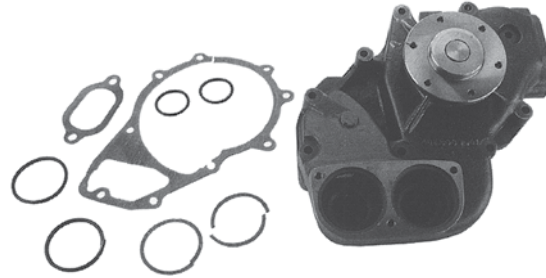

OM 401/402/403 motor 129661-744215, OM 401/402/403 A/LA, OM 421/422/423 + A/LA, OM 441/442/443 + A/LA --motor 744215	<ul style="list-style-type: none"> EN Water pump DE Wasserpumpe FR Pompe à eau ES Bomba de agua PT Bomba d'agua RU Водяной насос 		403 200 7101	02.20164
---	--	--	--------------	----------

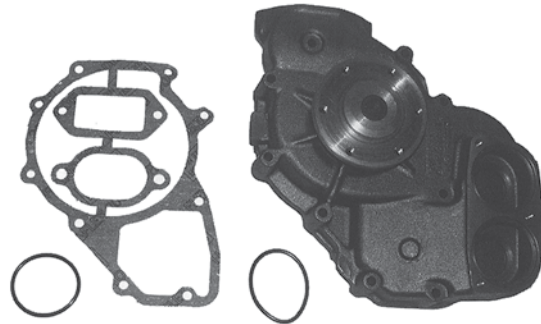

OM 402 LA (BM402.984), OM 441 LA (BM441.994)	<ul style="list-style-type: none"> EN Water pump DE Wasserpumpe FR Pompe à eau ES Bomba de agua PT Bomba d'agua RU Водяной насос 		403 200 7301	02.20165
---	--	--	--------------	----------

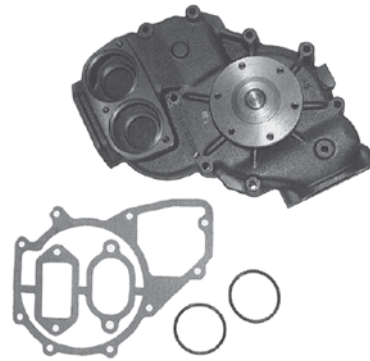

OM 401/402/403 A/LA, OM 421/422/423 + A/LA, OM 441/442/443 + A/LA motor 744216--	<ul style="list-style-type: none"> EN Water pump DE Wasserpumpe FR Pompe à eau ES Bomba de agua PT Bomba d'agua RU Водяной насос 		403 200 7701	02.20169
--	--	--	--------------	----------

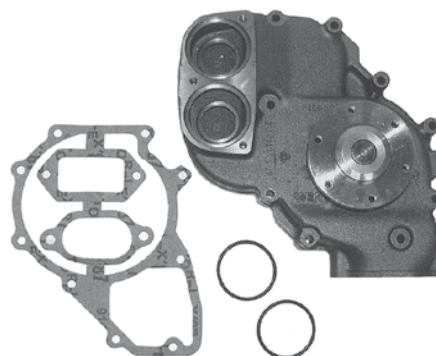

Water Pump & ThermostatWasserpumpe & Thermostat • Pompe à eau & Thermostat • Bomba de agua & Termostato
Bomba de Água & Termostato • Водяной насос и термостат

Application	Description	Details	Ref.	Erqo No.
OM 423 LA (BM 423.950), OM 443 LA (BM 443.980) motor 744216 --	<ul style="list-style-type: none"> EN Water pump DE Wasserpumpe FR Pompe à eau ES Bomba de agua PT Bomba d'água RU Водяной насос 		422 200 1301	02.20174 

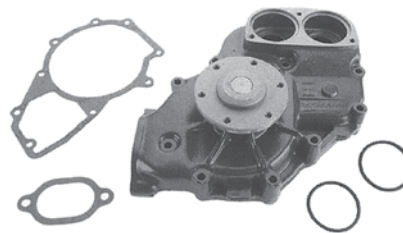

OM 403 (BM 403.900), OM 443 A (BM443.940)	<ul style="list-style-type: none"> EN Water pump DE Wasserpumpe FR Pompe à eau ES Bomba de agua PT Bomba d'água RU Водяной насос 		403 200 7401	02.20166 
---	--	--	--------------	---

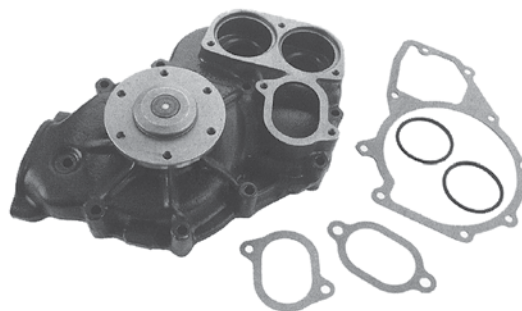

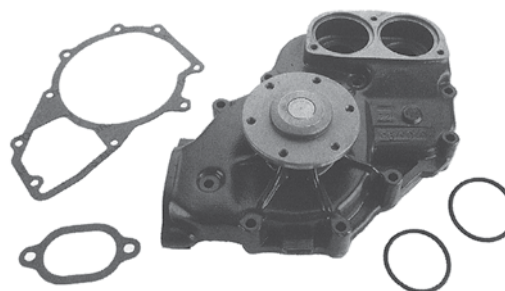

OM 423 LA (BM 423.950), OM 443 LA (BM 443.980) motor 744216--	<ul style="list-style-type: none"> EN Water pump DE Wasserpumpe FR Pompe à eau ES Bomba de agua PT Bomba d'água RU Водяной насос 		422 200 1401	02.20175 
---	--	--	--------------	---

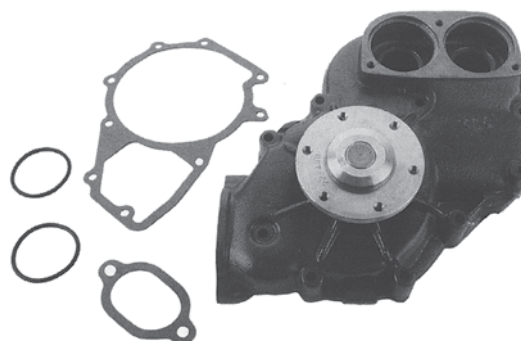

OM 423 LA (BM 423.950), OM 443 LA (BM 443.980) --motor 744215	<ul style="list-style-type: none"> EN Water pump DE Wasserpumpe FR Pompe à eau ES Bomba de agua PT Bomba d'água RU Водяной насос 		422 200 1001	02.20172 
---	--	--	--------------	---

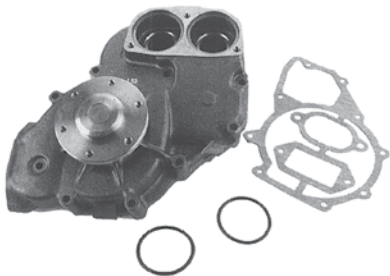

THE ORIGINAL NUMBERS OF THE VEHICLE MANUFACTURER MAY BE USED FOR COMPARISON PURPOSES ONLY AND MUST NOT BE MENTIONED ON INVOICES TO VEHICLE OWNERS.

Application	Description	Details	Ref.	Erqo No.
OM 441 (BM 900-933) OM 442 (BM 900-939) --motor 744215	<ul style="list-style-type: none"> EN Water pump DE Wasserpumpe FR Pompe à eau ES Bomba de agua PT Bomba d'água RU Водяной насос 		441 200 0201	02.20177 







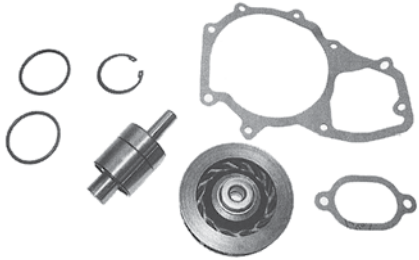

OM 441 (BM 900-933) OM 442 (BM 900-939) motor 744216--	<ul style="list-style-type: none"> EN Water pump DE Wasserpumpe FR Pompe à eau ES Bomba de agua PT Bomba d'água RU Водяной насос 		441 200 0301	02.20178 
--	--	---	--------------	---

SA 018408/15, SA 018408/20	<ul style="list-style-type: none"> EN Water pump DE Wasserpumpe FR Pompe à eau ES Bomba de agua PT Bomba d'água RU Водяной насос 		422 200 1101	02.20173 
-------------------------------	--	--	--------------	---

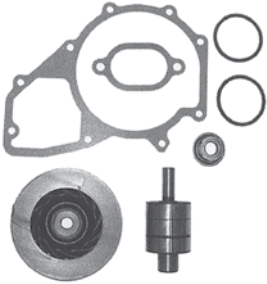

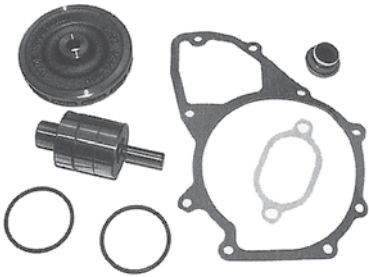

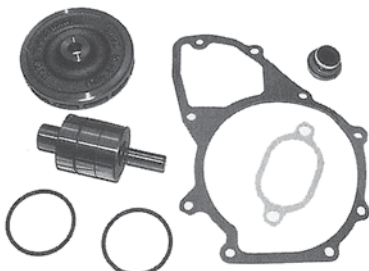





SA 018408/12, SA 018408/29, SA 018408/30	<ul style="list-style-type: none"> EN Water pump DE Wasserpumpe FR Pompe à eau ES Bomba de agua PT Bomba d'água RU Водяной насос 		403 200 7501	02.20167 
--	--	--	--------------	---

Sample

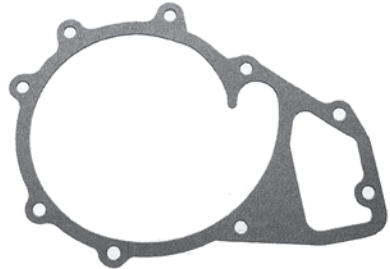
THE ORIGINAL NUMBERS OF THE VEHICLE MANUFACTURER MAY BE USED FOR COMPARISON PURPOSES ONLY AND MUST NOT BE MENTIONED ON INVOICES TO VEHICLE OWNERS.

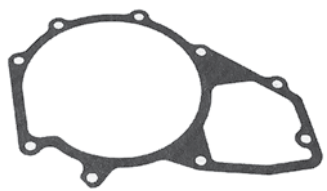
Application	Description	Details	Ref.	Erqo No.
OM 401/421/441 + A/LA, OM 402/422/442 + A/LA, OM 403/423/443 + A/LA	<ul style="list-style-type: none"> EN Repair kit, water pump to fit DE Reparatursatz, Wasserpumpe passend FR Kit de réparation, Pompe à eau ES Kit de reparación, Bomba de agua PT Jogo reparo, bomba d'água para RU Ремкомплект, Водяной насос 		422 200 0304	02.20181 
OM 423 LA (BM 423.950), OM 443 LA (BM 443.980)	<ul style="list-style-type: none"> EN Repair kit, water pump to fit DE Reparatursatz, Wasserpumpe passend FR Kit de réparation, Pompe à eau ES Kit de reparación, Bomba de agua PT Jogo reparo, bomba d'água para RU Ремкомплект, Водяной насос 		422 200 0504	02.20183 
OM 441, (- motor 886336), OM 442, (- motor 886336)	<ul style="list-style-type: none"> EN Repair kit, water pump DE Reparatursatz, Wasserpumpe FR Kit de réparation, Pompe à eau ES Kit de reparación, Bomba de agua PT Jogo reparo, bomba d'água RU Ремкомплект, Водяной насос 		441 200 0104	02.20187 
OM 441 (BM 900-933) OM 442 (BM 900-939)	<ul style="list-style-type: none"> EN Repair kit, water pump to fit DE Reparatursatz, Wasserpumpe passend FR Kit de réparation, Pompe à eau ES Kit de reparación, Bomba de agua PT Jogo reparo, bomba d'água para RU Ремонтный комплект, Водяной насос 		441 200 0204	02.20188 

THE ORIGINAL NUMBERS OF THE VEHICLE MANUFACTURER MAY BE USED FOR COMPARISON PURPOSES ONLY AND MUST NOT BE MENTIONED ON INVOICES TO VEHICLE OWNERS.











Application	Description	Details	Ref.	Erqo No.
<p>1</p> <p>OM 401/402/403 + A/LA, OM 421/422/423 + A/LA --motor 257475</p>	<p>EN Gasket kit, water pump DE Dichtsatz, Wasserpumpe FR Kit de joints, pompe à eau ES Juego de juntas, Bomba de agua PT Jogo junta, bomba d'água RU Комплект уплотнителей, Водяной насос</p>		403 200 6901	<p>02.20162</p> 
<p>OM 401/402/403 + A/LA, OM 421/422/423 + A/LA, OM 441/442/443 + A/LA motor 257476--</p>	<p>EN Gasket kit, water pump for pumps with 15 mm shaft dia DE Dichtsatz, Wasserpumpe für Pumpen mit 15 mm Wellendurchmesser FR Kit de joints, pompe à eau ES Juego de juntas, Bomba de agua PT Jogo junta, bomba d'água RU Комплект уплотнителей, Водяной насос</p>		422 200 0901	<p>02.20171</p> 
<p>OM 401/421/441 + A/LA, OM 402/422/442 + A/LA, OM 403/423/443 + A/LA --motor 129660</p>	<p>EN Gasket DE Dichtung FR Joint ES Junta PT Junta RU Уплотнение</p>		442 201 1080	<p>02.20223</p> 
<p>OM 401/421/441 + A/LA, OM 402/422/442 + A/LA, OM 403/423/443 + A/LA motor 129661--</p>	<p>EN Gasket DE Dichtung FR Joint ES Junta PT Junta RU Уплотнение</p>		442 201 0080	<p>02.20222</p> 
<p>OM 401/402/403+ A/LA, OM 421/422/423 + A/LA --motor 054694</p>	<p>EN Repair kit, water pump DE Reparatursatz, Wasserpumpe FR Kit de réparation, pompe à eau ES Kit de reparación, Bomba de agua PT Jogo reparo, bomba d'água RU Ремонтный комплект, Водяной насос</p>		000 201 3811	<p>02.23157</p> 

Application	Description	Details	Ref.	Erqo No.
OM 401/402/403 + A/LA, OM 421/422/423 + A/LA --motor 054694	EN Slide ring seal DE Gleitringdichtung FR Presse étoupe ES Retén delantero PT Gaxeta bomba d'água RU Торцевое уплотнение		000 201 7219	02.23158 
OM 401/402/403 + A/LA, OM 421/422/423 + A/LA --motor 054694	EN Thrust ring DE Druckring FR Fret de joint speed ES Anillo de presión PT Anel pressão RU Упорное кольцо		000 201 0463	02.20220 
OM 401/402/403 + A/LA, OM 421/422/423 + A/LA --motor 054694	EN Boot DE Manschette FR Manchon ES Retén PT Anel vedação RU Манжета		003 997 9245	02.22622 
OM 401/402/403 + A/LA, OM 421/422/423 + A/LA, OM 441/442/443 + A/LA motor 054695--	EN Slide ring seal DE Gleitringdichtung FR Presse étoupe ES Retén delantero PT Gaxeta bomba d'água RU Торцевое уплотнение		001 201 1719	02.20218 
OM 401/402/403 + A/LA, OM 421/422/423 + A/LA, OM 441/442/443 + A/LA	EN Hub DE Nabe FR Moueu ES Vuje PT Cubo RU Ступица		542 202 0114	02.20231 
OM 401/402 LA --motor 723353, OM 441 A/LA -- motor 712353, OM 442/443 A/LA motor 632565-712353	EN Pulley DE Riemenscheibe FR Poulie à courroie ES Polea de transmisión PT Polia RU Ременный шкив		403 202 1310	02.20227 

THE ORIGINAL NUMBERS OF THE VEHICLE MANUFACTURER MAY BE USED FOR COMPARISON PURPOSES ONLY AND MUST NOT BE MENTIONED ON INVOICES TO VEHICLE OWNERS.

Application	Description	Details	Ref.	Erqo No.
OM 401/402 LA, OM 441/442/443 + A/LA motor 712354-833554	<ul style="list-style-type: none"> EN Pulley DE Riemenschelbe FR Poulie à courroie ES Polea de transmisión PT Polia RU Ременный шкив 		442 202 0210	02.20229 
OM 401/402 +A/LA OM 422/423 +A/LA OM 441/442/443 + A/LA motor 833555 --	<ul style="list-style-type: none"> EN Pulley DE Riemenschelbe FR Poulie à courroie ES Polea de transmisión PT Polia RU Ременный шкив 		403 202 0610	02.20225 
OM 402, OM 421/422 +A motor 029962-042603	<ul style="list-style-type: none"> EN Pulley DE Riemenschelbe FR Poulie à courroie ES Polea de transmisión PT Polia RU Ременный шкив 		403 202 0710	02.20226 
OM 401/402/403, OM 421/422 + A , OM 442	<ul style="list-style-type: none"> EN Pulley DE Riemenschelbe FR Poulie à courroie ES Polea de transmisión PT Polia RU Ременный шкив 		403 202 1710	02.20228 
OM 401/402/403 + A/LA, OM 421/422/423 + A/LA, OM 441/442/443 + A/LA --motor 733625	<ul style="list-style-type: none"> EN Thermostat cover DE Thermostatdeckel FR Couvercle de thermostat ES Tapa del termostato PT Tampa termostato RU Крышка термостата 		442 201 0531	02.20219 

THE ORIGINAL NUMBERS OF THE VEHICLE MANUFACTURER MAY BE USED FOR COMPARISON PURPOSES ONLY AND MUST NOT BE MENTIONED ON INVOICES TO VEHICLE OWNERS.





Application	Description	Details	Ref.	Erqo No.
OM 401/402/403 + A/LA, OM 421/422/423 + A/LA, OM 441/442/443 + A/LA	EN Thermostat, 60°C DE Thermostat, 60°C FR Thermostat, 60°C ES Termostato, 60°C PT Termostato, 60°C RU Термостат, 60°C			02.23160 
OM 401/402/403 + A/LA, OM 421/422/423 + A/LA, OM 441/442/443 + A/LA	EN Thermostat, 65°C DE Thermostat, 65°C FR Thermostat, 65°C ES Termostato, 65°C PT Termostato, 65°C RU Термостат, 65°C		002 203 3075	02.23159 
OM 401/402/403 + A/LA, OM 421/422/423 + A/LA, OM 441/442/443 + A/LA	EN Thermostat, 71 °C DE Thermostat, 71 °C FR Thermostat, 71 °C ES Termostato, 71 °C PT Termostato, 71 °C RU Термостат, 71 °C		003 203 7975	02.20234 
OM 401/402/403 + A/LA, OM 421/422/423 + A/LA, OM 441/442/443 + A/LA	EN Thermostat, 75°C DE Thermostat, 75°C FR Thermostat, 75°C ES Termostato, 75°C PT Termostato, 75°C RU Термостат, 75°C			02.23161 
OM 401/402/403 + A/LA, OM 421/422/423 + A/LA, OM 441/442/443 + A/LA	EN Thermostat, 79°C DE Thermostat, 79°C FR Thermostat, 79°C ES Termostato, 79°C PT Termostato, 79°C RU Термостат, 79°C			02.23162 

THE ORIGINAL NUMBERS OF THE VEHICLE MANUFACTURER MAY BE USED FOR COMPARISON PURPOSES ONLY AND MUST NOT BE MENTIONED ON INVOICES TO VEHICLE OWNERS.



Water Pump & Thermostat

Wasserpumpe & Thermostat • Pompe à eau & Thermostat • Bomba de agua & Termostato
 Bomba de Água & Termostato • Водяной насос и термостат

1

Application	Description	Details	Ref.	Erqo No.
OM 401/402/403 + A/LA, OM 421/422/423 + A/LA, OM 441/442/443 + A/LA	EN Thermostat, 83°C DE Thermostat, 83°C FR Thermostat, 83°C ES Termostato, 83°C PT Termostato, 83°C RU Термостат, 83°C		004 203 8375	02.20235 
OM 401/402/403 + A/LA, OM 421/422/423 + A/LA, OM 441/442/443 + A/LA	EN Thermostat, 87°C DE Thermostat, 87°C FR Thermostat, 87°C ES Termostato, 87°C PT Termostato, 87°C RU Термостат, 87°C			02.23163 
OM 401/402/403 + A/LA, OM 421/422/423 + A/LA, OM 441/442/443 + A/LA	EN O-ring DE O-Ring FR Joint torique ES Junta tórica PT Anel RU Уплотнительное кольцо	60,0 x 4,0 mm	003 997 5748	02.22706 

THE ORIGINAL NUMBERS OF THE VEHICLE MANUFACTURER MAY BE USED FOR COMPARISON PURPOSES ONLY AND MUST NOT BE MENTIONED ON INVOICES TO VEHICLE OWNERS.

Application	Description	Details	Ref.	Erqo No.
OM 401 LA, OM 441 LA, OM 442 + A, OM 443 BM 905 -- motor 732916, -- motor 733625, -- motor 870302	EN Visco fan DE Visco-Lüfter FR Ventilateur thermostatique ES Ventilador Visco PT Ventilador magnético RU Вентилятор с вискомуфтой	Ø 680 mm	002 205 1506	02.20241 
OM 401 LA -- motor 732916; OM 442	EN Visco fan DE Visco-Lüfter FR Ventilateur thermostatique ES Ventilador Visco PT Ventilador magnético RU Вентилятор с вискомуфтой	Ø 680 mm	002 205 8306	02.20246 
OM 401 LA motor 732917 - 870302; OM 402 LA BM971; OM 423 BM 909; OM 423 LA BM 950; OM 441 LA motor 732917 - 870302; OM 442 LA -- motor 664554; OM 443 A BM 940; OM 443 LA BM 980	EN Visco fan DE Visco-Lüfter FR Ventilateur thermostatique ES Ventilador Visco PT Ventilador magnético RU Вентилятор с вискомуфтой	Ø 680 mm	002 205 7806	02.20245 

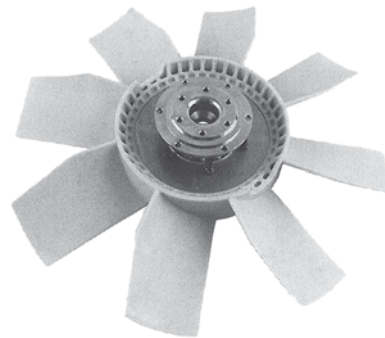
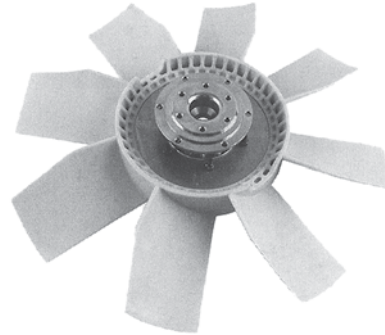

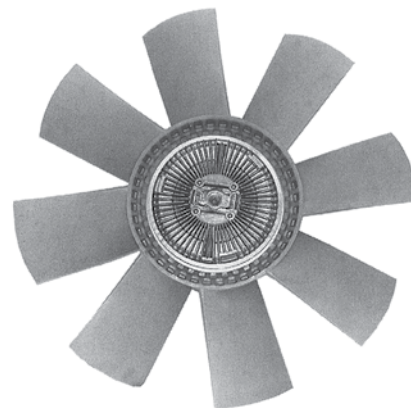

Sample



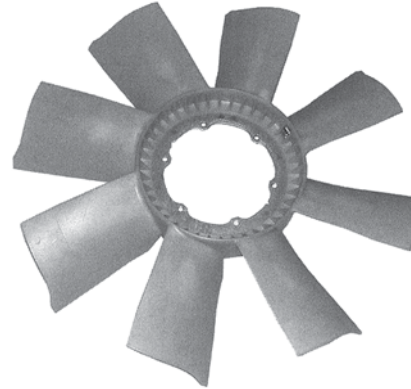

1

Application	Description	Details	Ref.	Erqo No.
OM 402 LA, OM 441 LA, OM 442 A/LA motor 788787 --	<ul style="list-style-type: none"> EN Fan DE Lüfter FR Ventilateur ES Ventilador PT Ventilador RU Вентилятор 	Ø 750 mm	003 205 0006	02.20249 



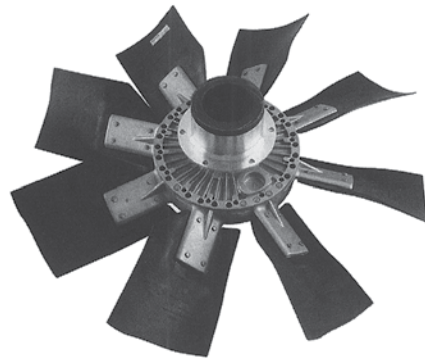

OM 402 LA, OM 442 A/LA -- motor 788786	<ul style="list-style-type: none"> EN Visco fan DE Visco-Lüfter FR Ventilateur thermostatique ES Ventilador Visco PT Ventilador magnético RU Вентилятор с вискомуфтой 	Ø 720 mm	002 205 9706	02.20248 
--	---	----------	--------------	--

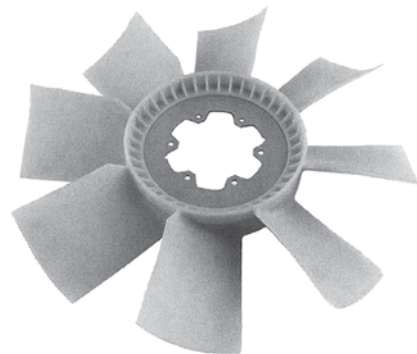

OM 401 LA, OM 441 LA motor 870303 --, motor 893265 --	<ul style="list-style-type: none"> EN Fan DE Lüfter FR Ventilateur ES Ventilador PT Ventilador RU Вентилятор 	Ø 680 mm	003 205 1606	02.20250 
--	--	----------	--------------	---



Application	Description	Details	Ref.	Erqo No.
OM 422 + A/LA, OM 423	<ul style="list-style-type: none"> EN Visco fan DE Visco-Lüfter FR Ventilateur thermostatique ES Ventilador Visco PT Ventilador magnético RU Вентилятор с вискомуфтой 	Ø 680 mm	002 205 6206	02.20243 
OM 422 N MBSA-RSA	<ul style="list-style-type: none"> EN Fan, steel old version DE Lüfter, Stahl alte Ausführung FR Ventilateur, Acier ancienne version ES Ventilador, acero version antigua PT Ventilador, aço versão antiga RU Вентилятор, Сталь старая версия 	Ø 620 mm	001 205 1206	02.23164 
OM 422 N MBSA-RSA	<ul style="list-style-type: none"> EN Fan, aluminium new version DE Lüfter, Aluminium neue Ausführung FR Ventilateur, Aluminium nouvelle version ES Ventilador, aluminio nueva versión PT Ventilador, alumínio versão nova RU Вентилятор, Алюминий нового типа 	Ø 620 mm	002 205 7006	02.20244 

Application	Description	Details	Ref.	Erqo No.
OM 422 A	<ul style="list-style-type: none"> EN Fan, aluminium DE Lüfter, Aluminium FR Ventilateur, Aluminium ES Ventilador, aluminio PT Ventilador, alumínio RU Вентилятор, Алюминий 	Ø 680 mm	002 205 9306	02.20247

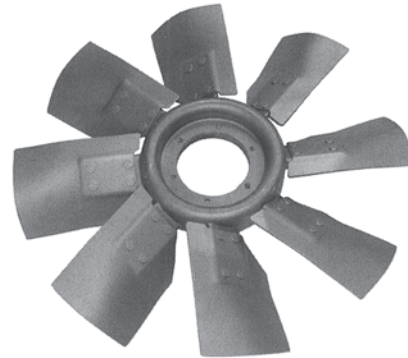

OM 422	<ul style="list-style-type: none"> EN Fan DE Lüfter FR Ventilateur ES Ventilador PT Ventilador RU Вентилятор 	Ø 680 mm	001 205 6106	02.20238
--------	--	----------	--------------	----------

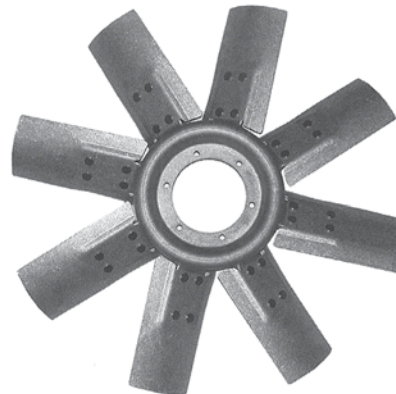

OM 422 T MBSA-RSA	<ul style="list-style-type: none"> EN Fan DE Lüfter FR Ventilateur ES Ventilador PT Ventilador RU Вентилятор 	Ø 680 mm	001 205 6206	02.20239
----------------------	--	----------	--------------	----------

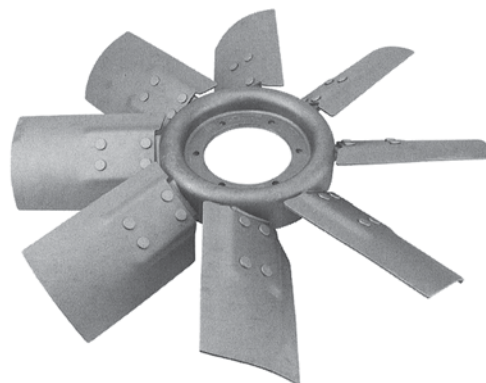

Application	Description	Details	Ref.	Erqo No.
OM 442 A/LA BM901	<ul style="list-style-type: none"> EN Fan DE Lüfter FR Ventilateur ES Ventilador PT Ventilador RU Вентилятор 	Ø 915 mm	444 200 0123	02.20194

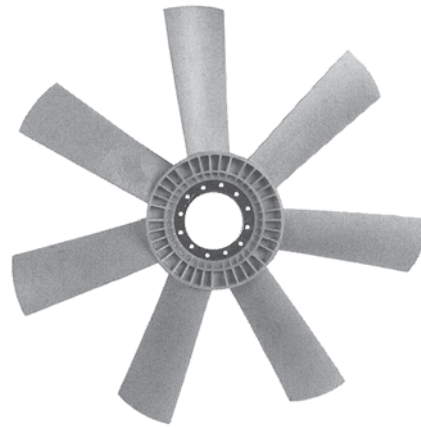

1

OM 402/403,
OM 421/422,
OM 441/442

- EN Fan ring
- DE Lüfterring
- FR Anneau de ventilateur
- ES Aro del ventilador
- PT Aro defletor
- RU Кольцо вентилятора

403 200 0495

02.20210

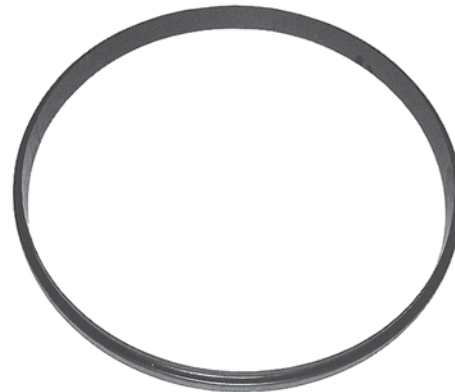

OM 401 LA,
OM 422/423 +
A/LA,
OM 441/442/443 +
A/LA







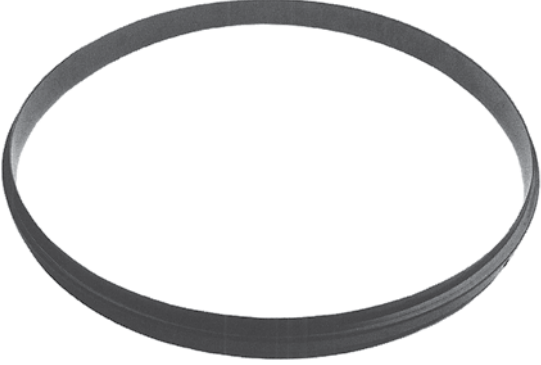

- EN Fan ring
- DE Lüfterring
- FR Anneau de ventilateur
- ES Aro del ventilador
- PT Aro defletor
- RU Кольцо вентилятора

442 200 0195











02.20211





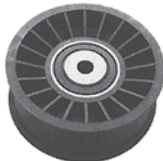

1







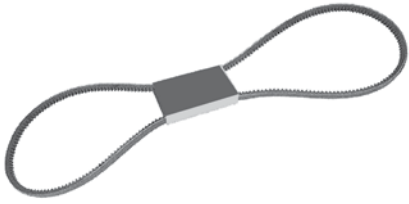

Application	Description	Details	Ref.	Erqo No.
OM 402 LA, OM 442 A/LA -- motor 733625 -- motor 788786	<ul style="list-style-type: none"> EN Fan ring DE Lüfterring FR Anneau de ventilateur ES Aro del ventilador PT Aro defletor RU Кольцо вентилятора 		442 200 0595	02.20212 
OM 402 LA, OM 441 LA, OM 442 A/LA motor 733626 --, motor 788787 --	<ul style="list-style-type: none"> EN Fan ring DE Lüfterring FR Anneau d'aérateur ES Anillo del ventilador PT Aro defletor RU Кольцо вентилятора 		442 200 1195	02.20213 
SA	<ul style="list-style-type: none"> EN Hub, fan DE Nabe, Lüfter FR Moyeu, ventilateur ES Buje, Ventilador PT Acoplamento hélice RU Ступица, Вентилятор 		403 200 0926	02.20195 
OM 402 LA, OM 441/442 A/LA motor 788787 --	<ul style="list-style-type: none"> EN Visco coupling DE Visco-Kupplung FR Moyeu de ventilateur ES Embrague Visco PT Magnético hélice RU Вискомуфта 		000 200 8122	02.20193 

Sample

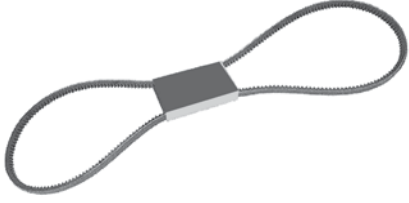
Application	Description	Details	Ref.	Erqo No.
OM 401 LA, OM 441 LA motor 870303 --	<ul style="list-style-type: none"> EN Visco coupling DE Visco-Kupplung FR Embrayage Visco ES Embrague Visco PT Magnético hélice RU Вискомуфта 		000 200 4622	02.20189 
OM 422/423, OM 442 + A, OM 443	<ul style="list-style-type: none"> EN Bracket, left DE Halter, links FR Support, gauche ES Sujeción, izquierdo PT Suporte, esquerdo RU Кронштейн, лев 		423 205 0540	02.20251 
OM 422/423 + A/LA, OM 442/443 + A/LA	<ul style="list-style-type: none"> EN Bracket, lower DE Halter, unten FR Support, inférieur ES Sujeción, inferior PT Suporte, inferior RU Кронштейн, нижний 		423 205 0740	02.20252 
OM 422/423, OM 442 + A, OM 443	<ul style="list-style-type: none"> EN Bracket, right DE Halter, rechts FR Support, droite ES Sujeción, derecho PT Suporte, direito RU Кронштейн, прав. 		442 205 3940	02.20253 
OM 401/402 LA, OM 441/442 LA	<ul style="list-style-type: none"> EN Tension roller DE Spannrolle FR Galet tendeur ES Rodillo tensor PT Polia RU Натяжной ролик 		442 200 0770	02.20209 

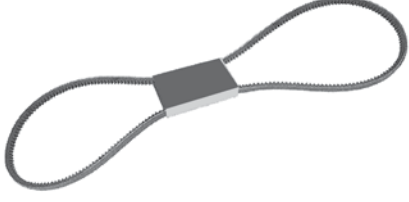

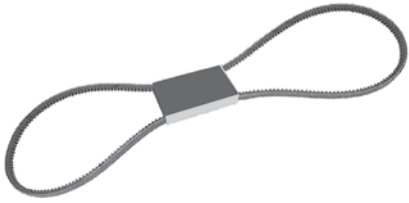
Application	Description	Details	Ref.	Erqo No.
OM 401, OM 402, OM 403	EN V-belt DE Keilriemen FR Courroie ES Correa trapezoidal PT Correia-V RU Клиновйй ремень	AVX 13 x 1475 mm	003 997 2992	02.22783 
OM 401 / 402 / 403 + A/LA, OM 421 /422/423 + A/LA, OM 441 / 442 / 443 + A/LA	EN V-belt DE Keilriemen FR Courroie clavette ES Correa trapezoidal PT Correia-V RU Клиновйй ремень	AVX 13 x 1525 mm	003 997 3092	02.22784 
OM 401 / 402 LA, OM 421 /422/423 + A/LA, OM 441 / 442 / 443 + A/LA	EN V-belt DE Keilriemen FR Courroie ES Correa en V PT Correia v RU Клиновйй ремень	AVX 13 x 1550 mm	005 997 2792	02.22789 
OM 401 / 402 LA, OM 441 + LA, OM 442 + A/LA, OM 443 + A	EN V-belt DE Keilriemen FR Courroie clavette ES Correa trapezoidal PT Correia-V RU Клиновйй ремень	AVX 13 x 1575 mm	005 997 2892	02.22790 
OM 421, OM 422	EN V-belt DE Keilriemen FR Courroie ES Correa trapezoidal PT Correia V RU Клиновйй ремень	AVX 10 x 675 mm	006 997 8092	02.22792 

THE ORIGINAL NUMBERS OF THE VEHICLE MANUFACTURER MAY BE USED FOR COMPARISON PURPOSES ONLY AND MUST NOT BE MENTIONED ON INVOICES TO VEHICLE OWNERS.









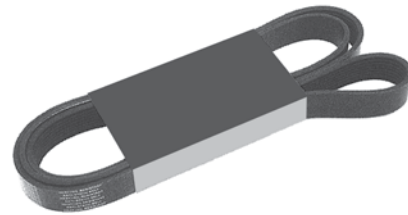

Application	Description	Details	Ref.	Erqo No.
OM 423	<ul style="list-style-type: none"> EN V-belt DE Keilriemen FR Courroie ES Correa trapezoidal PT Correia V RU Клиновй ремень 	AVX 13 x 1000 mm	003 997 5092	02.22785 
				
OM 423	<ul style="list-style-type: none"> EN V-belt DE Keilriemen FR Courroie ES Correa trapezoidal PT Correia V RU Клиновй ремень 	AVX 13 x 1350 mm	003 997 0392	02.22781 
				
OM 421 /422 + A , OM 441 / 442 + A	<ul style="list-style-type: none"> EN V-belt DE Keilriemen FR Courroie ES Correa trapezoidal PT Correia V RU Клиновй ремень 	AVX 13 x 2000 mm	006 997 9592	02.22793 
				
OM 423 LA, OM 442 LA	<ul style="list-style-type: none"> EN V-belt DE Keilriemen FR Courroie ES Correa trapezoidal PT Correia V RU Клиновй ремень 	AVX 13 x 1825 mm	007 997 0792	02.22794 
				
OM 401, OM 402	<ul style="list-style-type: none"> EN V-belt kit DE Keilriemensatz FR Jeu de courroies ES Kit de correas en V PT Jogo correias v RU Клиновй ремень 	2xAVX 13 x 1525 mm	004 997 9092	02.22787 
				

THE ORIGINAL NUMBERS OF THE VEHICLE MANUFACTURER MAY BE USED FOR COMPARISON PURPOSES ONLY AND MUST NOT BE MENTIONED ON INVOICES TO VEHICLE OWNERS.

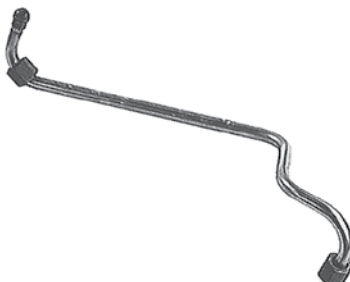
1











Application	Description	Details	Ref.	Erqo No.
OM 401, OM 402, OM 403, OM 421, OM 422 + A	<ul style="list-style-type: none"> EN V-belt kit DE Keilriemensatz FR Jeu de courroies ES Kit de correas en V PT Jogo correias v RU Клиновой ремень 	2 x AVX 13 x 2025 mm	003 997 1292	02.22782 
OM 401, OM 402, OM 403	<ul style="list-style-type: none"> EN V-belt kit DE Keilriemensatz FR Jeu de courroies ES Kit de correas en V PT Jogo correias v RU Клиновой ремень 	2 x AVX 13 x 2050 mm	005 997 4292	02.22791 
OM 442 + A/LA	<ul style="list-style-type: none"> EN Multiribbed belt DE Keilrippenriemen FR Courroie ES Correa nervada PT Correia RU Поликлиновой ремень 	9 PK 2618 mm	011 997 6692	02.22796 









Application	Description	Details	Ref.	Erqo No.
OM 401, OM 402, OM 403	<ul style="list-style-type: none"> EN Line DE Leitung FR Flexible ES Tubería PT Tubo RU Трубопровод 		403 200 1652	02.20197 
OM 401, OM 402, OM 403, OM 421.905-907 (-motor 468903), OM 421.908-951, OM 422, (- motor 468903), OM 422 A + LA, OM 423, (- motor 468903), OM 423 A + LA (-motor 592679)	<ul style="list-style-type: none"> EN Line DE Leitung FR Flexible ES Tubería PT Tubo RU Трубопровод 		422 200 0752	02.20201 
OM 402 LA, BM 971-975, OM 402 LA, (-motor 707584), OM 421.905-907, (motor 468904- 794006), OM 422, (motor 468904-794006), OM 423, (motor 468904-794006), OM 441 (-motor 794006), OM 442 + A + LA (-motor 794006)	<ul style="list-style-type: none"> EN Line DE Leitung FR Flexible ES Tubería PT Tubo RU Трубопровод 		442 200 3152	02.20205 
OM 402 LA, (motor 707585 -), OM 421.905-906, (motor 794007 -), OM 422, (motor 794007 -), OM 423, (motor 794007 -), OM 441, (motor 794007 -), OM 441 LA BM 962/983/987, OM 442 + A + LA (motor 794007-)	<ul style="list-style-type: none"> EN Line DE Leitung FR Flexible ES Tubería PT Tubo RU Трубопровод 		442 200 0553	02.20208 
OM 402 LA, OM 423 A + LA, (motor 592680 -) OM 441, OM 442 + A + LA, OM 443 A + LA	<ul style="list-style-type: none"> EN Line DE Leitung FR Flexible ES Tubería PT Tubo RU Трубопровод 		422 200 2952	02.20203 

THE ORIGINAL NUMBERS OF THE VEHICLE MANUFACTURER MAY BE USED FOR COMPARISON PURPOSES ONLY AND MUST NOT BE MENTIONED ON INVOICES TO VEHICLE OWNERS.

1

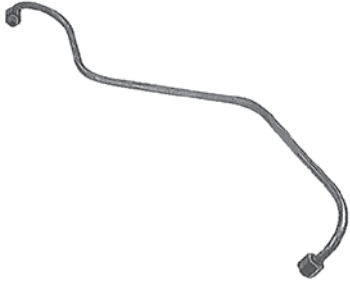

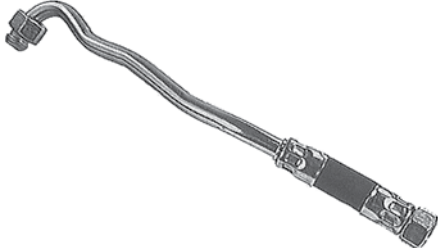

Application	Description	Details	Ref.	Erqo No.
OM 402, (- motor 001925), OM 403, (- motor 010092)	<ul style="list-style-type: none"> EN Line DE Leitung FR Flexible ES Tubería PT Tubo RU Трубопровод 		403 200 0452	02.20196 
OM 401, OM 402, (motor 001926-), OM 403, (motor 001926 -)	<ul style="list-style-type: none"> EN Line DE Leitung FR Flexible ES Tubería PT Tubo RU Трубопровод 		403 200 2152	02.20199 
OM 402 LA, (- motor 707584), OM 402, OM 421.905-907, (motor 468904-794006), OM 422, (motor 468904 -), OM 423, (motor 468904-794006), OM 441, (- motor 794006), OM 442 + A + LA (- motor 794006)	<ul style="list-style-type: none"> EN Line DE Leitung FR Flexible ES Tubería PT Tubo RU Трубопровод 		442 200 2452	02.20204 
OM 401, OM 402, OM 403, OM 421.905-907, (- motor 468903), OM 422, (- motor 468903), OM 423, (- motor 468903)	<ul style="list-style-type: none"> EN Line DE Leitung FR Flexible ES Tubería PT Tubo RU Трубопровод 		403 200 1852	02.20198 
OM 402 LA, (motor 707585 -), OM 421.905-906, OM 423, (motor 794007 -), OM 441, (motor 794007 -), OM 441 A + LA, BM 962/983/987, OM 442 + A + LA, (motor 794007 -)	<ul style="list-style-type: none"> EN Line DE Leitung FR Flexible ES Tubería PT Tubo RU Трубопровод 		442 200 8252	02.20207 

THE ORIGINAL NUMBERS OF THE VEHICLE MANUFACTURER MAY BE USED FOR COMPARISON PURPOSES ONLY AND MUST NOT BE MENTIONED ON INVOICES TO VEHICLE OWNERS.

Application	Description	Details	Ref.	Erqo No.
OM 401 LA, OM 421, OM 422 A + LA, OM 423 A + LA, OM 441, OM 442 + A, OM 443 A + LA	EN Line DE Leitung FR Flexible ES Tubería PT Tubo RU Трубопровод		422 200 1552	02.20202 
OM 403 SA 18303	EN Line DE Leitung FR Flexible ES Tubería PT Tubo RU Трубопровод		424 200 0452	02.23165 
OM 402, OM 403	EN Line DE Leitung FR Flexible ES Tubería PT Tubo RU Трубопровод		403 200 2752	02.20200 

Steering Pump





Lenkhilfepumpe • Pompe de Direction • Bomba de Servodirección
Bomba de Direção • Насос гидра усилителя рулевого привода

Application	Description	Details	Ref.	Erqo No.
1 OM 401/402/403 + A/LA, OM 421/422/423 + A/LA, OM 441/442/443 + A/LA	<ul style="list-style-type: none"> EN Steering pump, steel DE Lenkhilfepumpe, Stahl FR Pompe de direction assistée, acier ES Bomba de servoconducción, acero PT Bomba hidráulica, aço RU Насос, стальной 	repl.ZF: 7673 955 116,100 bar	000 466 6701	02.21660 
OM 401/402/403 + A/LA, OM 421/422/423 + A/LA, OM 441/442/443 + A/LA	<ul style="list-style-type: none"> EN Steering pump, steel DE Lenkhilfepumpe, Stahl FR Pompe de direction assistée, acier ES Bomba de servoconducción, acero PT Bomba hidráulica, aço RU Насос, стальной 	repl. ZF: 7673 955 534,120 bar	001 466 1301	02.21661 
OM 401/402/403 + A/LA, OM 421/422/423 + A/LA, OM 441/442/443 + A/LA	<ul style="list-style-type: none"> EN Steering pump, aluminium DE Lenkhilfepumpe, Aluminium FR Pompe de direction assistée, aluminium ES Bomba de servoconducción, aluminio PT Bomba hidráulica, alumínio RU Насос, Алюминий 	repl.ZF: 7684 955 134,100 bar	000 460 6680	02.21640 
OM 401/402/403 + A/LA, OM 421/422/423 + A/LA, OM 441/442/443 + A/LA	<ul style="list-style-type: none"> EN Steering pump, aluminium DE Lenkhilfepumpe, Aluminium FR Pompe de direction assistée, aluminium ES Bomba de servoconducción, aluminio PT Bomba hidráulica, alumínio RU Насос, Алюминий 	repl.ZF: 7685 955 134,120 bar	001 460 2880	02.21645 
OM 402 LA, OM 442 A/LA	<ul style="list-style-type: none"> EN Steering pump DE Lenkhilfepumpe FR Pompe de direction assistée ES Bomba de servoconducción PT Bomba hidráulica RU Насос 	repl.ZF: 7677 955 201	001 460 0580	02.21644 

THE ORIGINAL NUMBERS OF THE VEHICLE MANUFACTURER MAY BE USED FOR COMPARISON PURPOSES ONLY AND MUST NOT BE MENTIONED ON INVOICES TO VEHICLE OWNERS.

Steering Pump





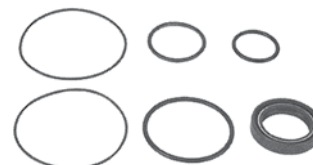



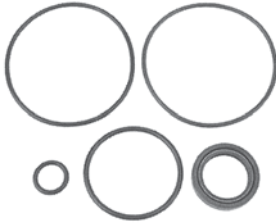

Lenkhilfepumpe • Pompe de Direction • Bomba de Servodirección
Bomba de Direção • Насос гидра усилителя рулевого привода

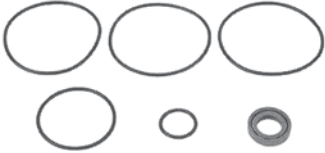
Application	Description	Details	Ref.	Erqo No.
OM 401/402 LA, OM 441/442 + LA	<ul style="list-style-type: none"> EN Steering pump DE Lenkhilfepumpe FR Pompe de direction assistée ES Bomba de servoconducción PT Bomba hidráulica RU Насос 	repl. LUK: 2 107 475	001 460 7080	02.21647 
				1
OM 401, OM 402 + LA, OM 422 + A, OM 441 / 442 + A/LA	<ul style="list-style-type: none"> EN Steering pump DE Lenkhilfepumpe FR Pompe de direction assistée ES Bomba de servoconducción PT Bomba hidráulica RU Насос 	repl. LUK: 542 0031 10	000 460 6780	02.21641 
OM 401/402/403 + A/LA, OM 421/422/423 + A/LA, OM 441/442/443 + A/LA	<ul style="list-style-type: none"> EN Repair kit, steering pump DE Reparatursatz, Lenkhilfepumpe FR Kit de réparation, pompe de direction ES Kit de reparación, Bomba de dirección PT Jogo reparo, bomba direção RU Ремонтный комплект, Насос 		000 460 7580	02.21643 
OM 402/403, OM 421 + A, OM 422/423,	<ul style="list-style-type: none"> EN Repair kit, steering pump DE Reparatursatz, Lenkhilfepumpe FR Kit de réparation, pompe de direction ES Kit de reparación, bomba de dirección PT Jogo reparo, bomba direção RU Ремонтный комплект, Насос 		000 586 9146	02.22111 
OM 402/403, OM 421 + A , OM 422/423, OM 441 LA	<ul style="list-style-type: none"> EN Repair kit, steering pump DE Reparatursatz, Lenkhilfepumpe FR Kit de réparation, pompe de direction ES Kit de reparación, Bomba de dirección PT Jogo reparo, bomba direção RU Комплект уплотнителей, Насос 		000 460 3080	02.21639 

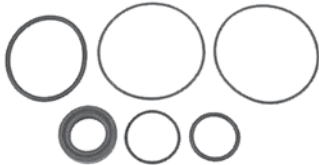

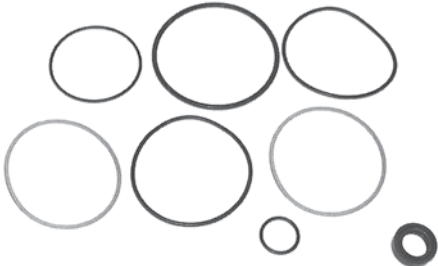

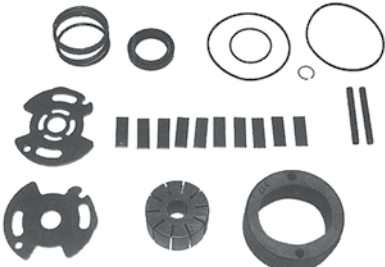



Steering Pump

Lenkhilfepumpe • Pompe de Direction • Bomba de Servodirección
Bomba de Direção • Насос гидро усилителя рулевого привода

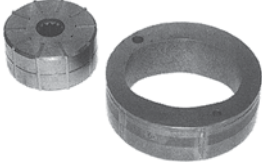







Application	Description	Details	Ref.	Erqo No.
1 OM 401/402/403 + A/LA, OM 421/422/423 + A/LA, OM 441/442/443 + A/LA	<ul style="list-style-type: none"> EN Repair kit, steering pump DE Reparatursatz, Lenkhilfepumpe FR Kit de réparation, pompe de direction ES Kit de reparación, Bomba de dirección PT Jogo reparo, bomba direção RU Комплект уплотнителей, Насос 		000 460 0361	02.21634 
OM 401/402/403 + A/LA, OM 421/422/423 + A/LA, OM 441/442/443 + A/LA	<ul style="list-style-type: none"> EN Repair kit, steering pump DE Reparatursatz, Lenkhilfepumpe FR Kit de réparation, pompe de direction ES Kit de reparación, Bomba de dirección PT Jogo reparo, bomba direção RU Ремонтный комплект, Насос 		000 586 2846	02.22110 
OM 401/402/403 + A/LA, OM 421/422/423 + A/LA, OM 441/442/443 + A/LA	<ul style="list-style-type: none"> EN Repair kit, steering pump DE Reparatursatz, Lenkhilfepumpe FR Kit de réparation, pompe de direction ES Kit de reparación, Bomba de dirección PT Jogo reparo, bomba direção RU Ремонтный комплект, Насос 		001 460 6480	02.21646 
OM 402 LA, OM 442 A/LA	<ul style="list-style-type: none"> EN Repair kit, steering pump DE Reparatursatz, Lenkhilfepumpe FR Kit de réparation, pompe de direction ES Kit de reparación, bomba de dirección PT Jogo reparo, bomba direção RU Комплект уплотнителей, Насос 		000 460 0061	02.21633 
OM 401/402, OM 421/422 + A/LA, OM 441 , OM 442 + A/LA, OM 443	<ul style="list-style-type: none"> EN Repair kit, steering pump DE Reparatursatz, Lenkhilfepumpe FR Kit de réparation, pompe de direction ES Kit de reparación, bomba de dirección PT Jogo reparo, bomba direção RU Ремонтный комплект 		000 460 2980	02.21638 







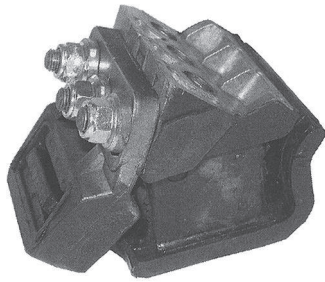

THE ORIGINAL NUMBERS OF THE VEHICLE MANUFACTURER MAY BE USED FOR COMPARISON PURPOSES ONLY AND MUST NOT BE MENTIONED ON INVOICES TO VEHICLE OWNERS.

Steering PumpLenkhilfpumpe • Pompe de Direction • Bomba de Servodirección
Bomba de Direção • Насос гидро усилителя рулевого привода

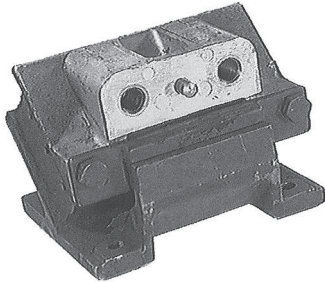

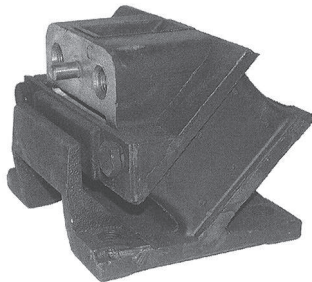

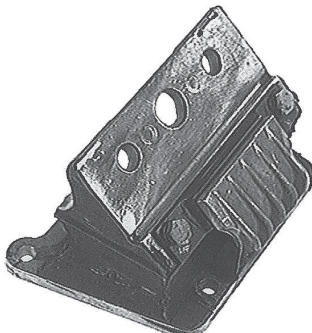



Application	Description	Details	Ref.	Erqo No.
OM 401/402/403 + A/LA, OM 421/422/423 + A/LA, OM 441/442/443 + A/LA	EN Repair kit, steering pump DE Reparatursatz, Lenkhilfpumpe FR Kit de réparation, pompe de direction ES Kit de reparación, bomba de dirección PT Jogo reparo, bomba direção RU Комплект ротора. Насос		000 466 6521	02.21670 
OM 401/421/441 + A/LA, OM 402/422/442 + A/LA, OM 403/423/443 + A/LA	EN Follower DE Mitnehmer FR Entraîneur ES Pieza de arrastre PT Arruela RU Поводок	48,5 mm	000 132 1410	02.19992 
motor 888001--				
OM 401/421/441 + A/LA, OM 402/422/442 + A/LA, OM 403/423/443 + A/LA	EN Follower DE Mitnehmer FR Entraîneur ES Pieza de arrastre PT Arruela RU Поводок	Ø 42 mm	000 132 0710	02.19991 
--motor 888000				

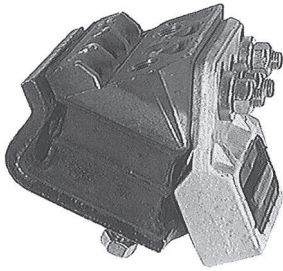

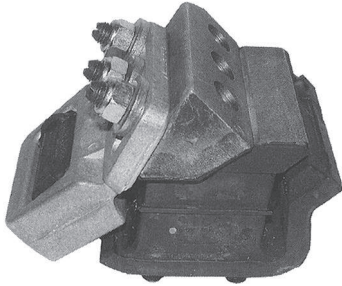

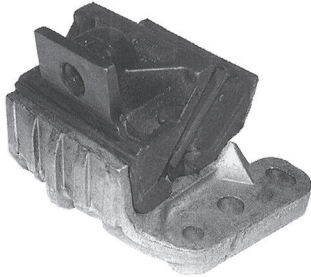

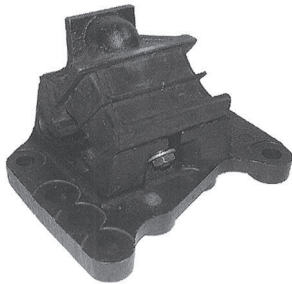

1

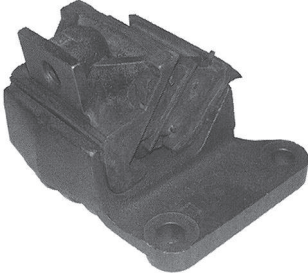
Application	Description	Details	Ref.	Erqo No.
OM 421/422, OM 423 LA, OM 442/443 LA	<ul style="list-style-type: none"> EN Oil seal DE Wellendichtring FR Joint speed ES Anillo retén PT Retentor RU Сальник 		013 997 6846	02.22646 
				
OM 423 LA (BM 909/950), OM 442 LA (BM 993/994/999), OM 443 LA (BM 980)	<ul style="list-style-type: none"> EN Oil nozzle DE Öldüse FR Gicleur d'huile ES Inyector de aceite PT Bujão cárter RU Масляная форсунка 		403 011 0026	02.19482 
				
OM 403, OM 421/422/423, OM 423 LA, OM 442/443 LA	<ul style="list-style-type: none"> EN O-ring DE O-Ring FR Joint torique ES Junta tórica PT Anel RU Уплотнительное кольцо 	90,0 x 5,0 mm	005 997 1945	02.22623 
				
OM 421/422/423, OM 423 LA, OM 442/443 LA	<ul style="list-style-type: none"> EN O-ring DE O-Ring FR Joint torique ES Junta tórica PT Anel RU Уплотнительное кольцо 	86,0 x 3,0 mm	011 997 4445	02.22626 
				

Application	Description	Details	Ref.	Erqo No.
BM 616/617, 652	<ul style="list-style-type: none"> EN Rubber mounting front DE Gummilager vorne FR Silentbloc avant ES Cojinete de goma delantero PT Coxim frente RU Резиновая подушка перед. 		617 240 0017	02.20259 
BM 387/389, 393/395, B M 620/621/622/ 623/624	<ul style="list-style-type: none"> EN Rubber mounting front - old version DE Gummilager vorne - alte Ausführung FR Silentbloc avant - ancienne version ES Cojinete de goma delantero - version antigua PT Coxim frente - versão anterior RU Резиновая подушка перед. - старое исполнение 		387 240 0317	02.20257 
BM 620/621/622/623/ 524/625, BM 645/646/647/ 648/649, BM 655/656/657/ 658/659	<ul style="list-style-type: none"> EN Rubber mounting front - new version DE Gummilager vorne - neue Ausführung FR Silentbloc avant - nouvelle version ES Cojinete de goma delantero - version actual PT Coxim frente - nova versão RU Резиновая подушка, перед. - нового типа 		658 241 0113	02.20292 
BM 620/621/622/ 623/624/625	<ul style="list-style-type: none"> EN Rubber mounting front DE Gummilager vorne FR Silentbloc avant ES Soporte delantero PT Coxim frente RU Резиновая подушка передн. 		620 240 0717	02.20264 

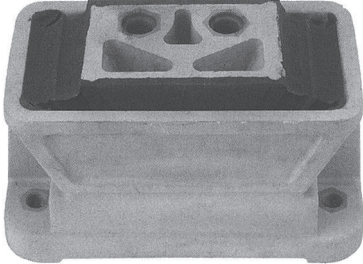
THE ORIGINAL NUMBERS OF THE VEHICLE MANUFACTURER MAY BE USED FOR COMPARISON PURPOSES ONLY AND MUST NOT BE MENTIONED ON INVOICES TO VEHICLE OWNERS.

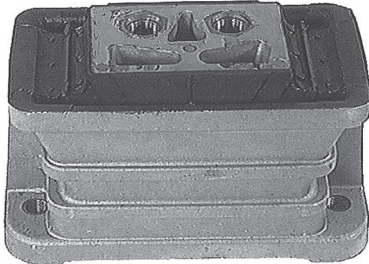
Application	Description	Details	Ref.	Erqo No.
BM 619, 625, 653/654	<ul style="list-style-type: none"> EN Rubber mounting front DE Gummilager vorne FR Silentbloc avant ES Silemblock delantero PT Coxim frente RU Резиновая подушка передн. 		617 240 0217	02.20260 
BM 625, 652/653/654/655/656, 659 (--K137001)	<ul style="list-style-type: none"> EN Rubber mounting front DE Gummilager vorne FR Silentbloc avant ES Silemblock delantero PT Coxim frente RU Резиновая подушка передн. 		653 241 0213	02.20288 
BM 625 (3233, 3234), BM 652/653/654 (K137002--)	<ul style="list-style-type: none"> EN Rubber mounting front, left and right DE Gummilager vorne, links und rechts FR Silentbloc avant, gauche et droit ES Silemblock delantero, izquierdo y derecho PT Coxim frente, esquerdo e direito RU Резиновая подушка передн., левый и правый 		652 241 0213	02.20287 
BM 625 (3534), 655/656, 659 (K137002--)	<ul style="list-style-type: none"> EN Rubber mounting front, right DE Gummilager vorne, rechts FR Silentbloc avant, droit ES Silemblock delantero, derecho PT Coxim frente, direito RU Резиновая подушка передн., правый 		655 241 0713	02.20290 

Application	Description	Details	Ref.	Erqo No.
BM 625 (3534), 655/656, 659 (K137002--)	<ul style="list-style-type: none"> EN Rubber mounting front, left DE Gummilager vorne, links FR Silentbloc avant, gauche ES Silemblock delantero, izquierdo PT Coxim frente, esquerdo RU Резиновая подушка передн., левый 		655 241 0613	02.20289 
BM 381/383/385, BM 652/653/654	<ul style="list-style-type: none"> EN Rubber mounting front DE Gummilager vorne FR Silentbloc avant ES Cojinete de goma delantero PT Coxim frente RU Резиновая подушка передн. 		615 240 0317	02.20258 
BM 383/385/387/389, 393/395, BM 616/617/619/620/ 21/622/623/624/625, BM652/653/654/655/ 656/657/658/659	<ul style="list-style-type: none"> EN Rubber mounting rear DE Gummilager hinten FR Silentbloc arrière ES Cojinete de goma trasero PT Coxim traz RU Резиновая подушка задн. 	M 16 x 1,5 / M 12 x 1,5 	645 240 0118	02.20278 
BM 620/621/622/623/ 624/625(3229), BM 645/646/647/648, 652/655/658/659	<ul style="list-style-type: none"> EN Rubber mounting, aluminium type rear DE Gummilager, Aluminium-Ausführung hinten FR Silentbloc, type aluminium arrière ES Soporte, tipo aluminio trasero PT Coxim, versão alumínio traz RU Резиновая подушка, Алюминий задн. 	M 18 x 1,5 / M 14 x 1,5 	645 240 0418	02.20281 

THE ORIGINAL NUMBERS OF THE VEHICLE MANUFACTURER MAY BE USED FOR COMPARISON PURPOSES ONLY AND MUST NOT BE MENTIONED ON INVOICES TO VEHICLE OWNERS.

Application	Description	Details	Ref.	Erqo No.
BM 620/621/622/623/ 624/625(3229), BM 645/646/647/648, 652/655/658/659	<p>EN Rubber mounting, steel type rear</p> <p>DE Gummilager, Stahl-Ausführung hinten</p> <p>FR Palier caoutchouc, type acier arrière</p> <p>ES Silemblock, tipo acero trasero</p> <p>PT Coxim, versão aço traz</p> <p>RU Резиновая подушка, стальной задн.</p>	M 18 x 1,5 / M 14 x 1,5	645 240 0318	02.20280 
BM 625(2650, 3050, 3053, 3548, 3550, 3553)	<p>EN Rubber mounting, aluminium type rear</p> <p>DE Gummilager, Aluminium-Ausführung hinten</p> <p>FR Silentbloc, type aluminium arrière</p> <p>ES Cojinete de goma, tipo aluminio trasero</p> <p>PT Coxim, versão alumínio traz</p> <p>RU Резиновая подушка, Алюминий задн.</p>	M 18 x 1,5 / M 14 x 1,5	645 240 0718	02.20284 
BM 624(2636, 3336, 3536, 3836)	<p>EN Rubber mounting, steel type rear</p> <p>DE Gummilager, Stahl-Ausführung hinten</p> <p>FR Silentbloc, type acier arrière</p> <p>ES Silemblock, tipo acero trasero</p> <p>PT Coxim, versão aço traz</p> <p>RU Резиновая подушка, стальной задн.</p>	M 18 x 1,5 / M 14 x 1,5	645 240 0918	02.20285 
BM 625, 652/653/ 654/655/656/659	<p>EN Rubber mounting rear</p> <p>DE Gummilager hinten</p> <p>FR Silentbloc arrière</p> <p>ES Silemblock trasero</p> <p>PT Coxim traz</p> <p>RU Резиновая подушка задн.</p>		652 240 0318	02.20286 

THE ORIGINAL NUMBERS OF THE VEHICLE MANUFACTURER MAY BE USED FOR COMPARISON PURPOSES ONLY AND MUST NOT BE MENTIONED ON INVOICES TO VEHICLE OWNERS.

Application	Description	Details	Ref.	Erqo No.
BM 616/617/619, 652/653/654 (- 5 557609)	<ul style="list-style-type: none"> EN Rubber mounting rear DE Gummilager hinten FR Silentbloc arrière ES Silemblock trasero PT Coxim traz RU Резиновая подушка задн. 		616 240 0618	02.20269 
NG/MK/SK	<ul style="list-style-type: none"> EN Screw DE Schraube FR Vis ES Tornillo PT Parafuso RU Болт 	M 12 x 30 	308676 012013	02.22941 
NG/MK/SK	<ul style="list-style-type: none"> EN Screw DE Schraube FR Vis ES Tornillo PT Parafuso RU Болт 	M 12 x 1,5 x 30 	000961 012151	02.22846 
NG/MK/SK	<ul style="list-style-type: none"> EN Screw DE Schraube FR Vis ES Tornillo PT Parafuso RU Болт 	M 14 x 40 	942 990 1304	02.22452 
NG/MK/SK	<ul style="list-style-type: none"> EN Screw DE Schraube FR Vis ES Tornillo PT Parafuso RU Болт 	M 14 x 1,5 x 30 	000961 014100	02.22849 

THE ORIGINAL NUMBERS OF THE VEHICLE MANUFACTURER MAY BE USED FOR COMPARISON PURPOSES ONLY AND MUST NOT BE MENTIONED ON INVOICES TO VEHICLE OWNERS.

Rubber MountingGummilager • Silentbloc • Soporte de Motor
Coxim • Опора резиновая

Application	Description	Details	Ref.	Erqo No.
NG/MK/SK	<ul style="list-style-type: none">EN ScrewDE SchraubeFR VisES TornilloPT ParafusoRU Болт	M 14 x 35	308676 014008	02.22945 



1

Clutch Cover & Clutch DiscDruckplatte & Mitnehmerscheibe • Mécanisme & Disque d'Embrayage • Maza & Disco de Embrague
Platô & Discô de Embragem • Нажимной и ведомый диски

Application	Description	Details	Ref.	Erqo No.
BM 625/653/654/655/656, 657/658/659	<ul style="list-style-type: none"> EN Clutch kit, 430 mm DE Kupplungssatz, 430 mm FR Kit d'embrayage, 430 mm ES Kit de embrague, 430 mm PT Kit embreagem, 430 mm RU Комплект для сцепления, 430 мм 	repl. Sachs: 3400 122 601	020 250 5001	02.20296 

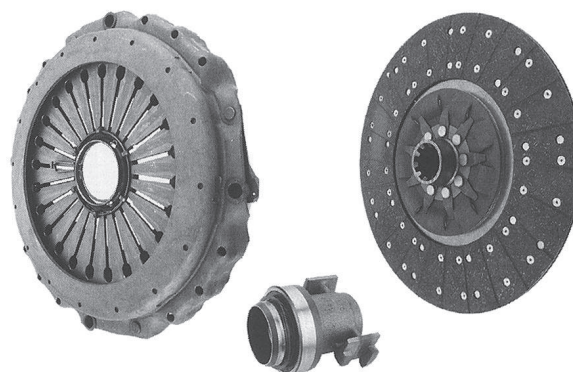

2

BM 652/653/654/656	<ul style="list-style-type: none"> EN Clutch kit, 430 mm DE Kupplungssatz, 430 mm FR Kit d'embrayage, 430 mm ES Kit de embrague, 430 mm PT Kit embreagem, 430 mm RU Комплект для сцепления, 430 мм 	repl. Sachs: 3400 123 001	020 250 4701	02.20294 
-----------------------	--	---------------------------	--------------	--

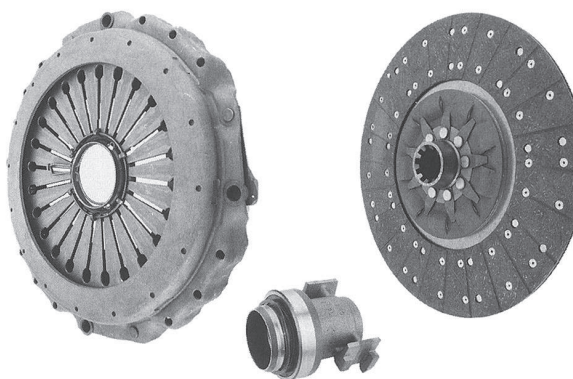

Sample

BM 652/653/654/655/656, 659	<ul style="list-style-type: none"> EN Clutch kit, 430 mm DE Kupplungssatz, 430 mm FR Kit d'embrayage, 430 mm ES Kit de embrague, 430 mm PT Kit embreagem, 430 mm RU Комплект для сцепления, 430 мм 	repl. Sachs: 3400 124 001	020 250 4901	02.20295 
-----------------------------------	--	---------------------------	--------------	---

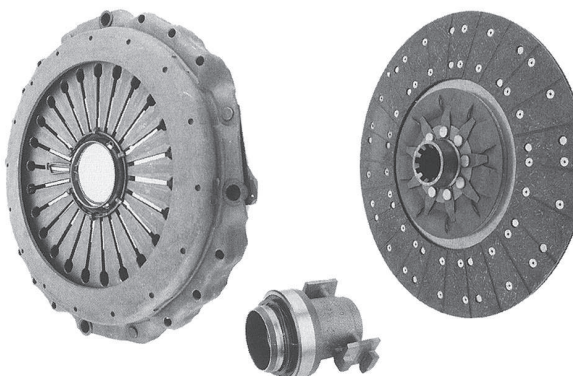

Sample

THE ORIGINAL NUMBERS OF THE VEHICLE MANUFACTURER MAY BE USED FOR COMPARISON PURPOSES ONLY AND MUST NOT BE MENTIONED ON INVOICES TO VEHICLE OWNERS.

Clutch Cover & Clutch Disc

Druckplatte & Mitnehmerscheibe • Mécanisme & Disque d'Embrayage • Maza & Disco de Embrague
Platô & Discô de Embreagem • Нажимной и ведомый диски

Application	Description	Details	Ref.	Erqo No.
BM 652/653/654/656	<ul style="list-style-type: none"> EN Clutch kit, 430 mm DE Kupplungssatz, 430 mm FR Kit d'embrayage, 430 mm ES Kit de embrague, 430 mm PT Kit embreagem, 430 mm RU Комплект для сцепления, 430 мм 	repl. Sachs: 3400 700 411	020 250 5201	02.20298

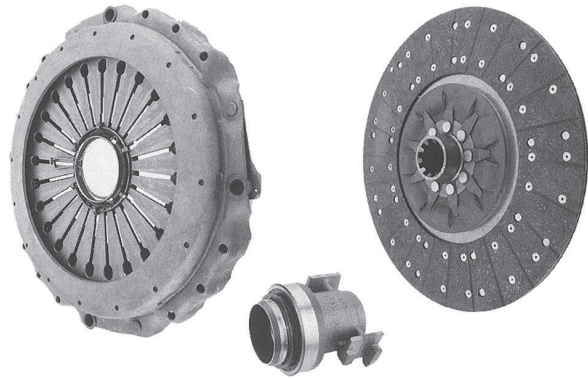

Sample

BM 655/656/657/658/659	<ul style="list-style-type: none"> EN Clutch kit, 430 mm DE Kupplungssatz, 430 mm FR Kit d'embrayage, 430 mm ES Kit de embrague, 430 mm PT Kit embreagem, 430 mm RU Комплект для сцепления, 430 мм 	repl. Sachs: 3400 122 901	020 250 5101	02.20297
---------------------------	--	---------------------------	--------------	----------

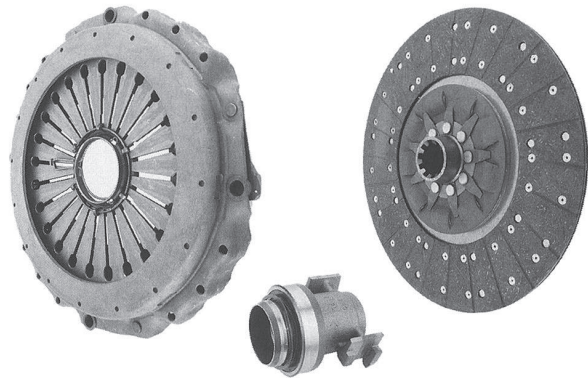

Sample

BM 380/383/385/387, BM 615/616/617	<ul style="list-style-type: none"> EN Clutch cover, 380 mm DE Druckplatte, 380 mm FR Mécanisme d'embrayage, 380 mm ES Maza de embrague, 380 mm PT Platô, 380 mm RU Нажимной диск, 380 мм 	repl. Sachs: 1882 302 131	003 250 2504	02.20384
---	--	---------------------------	--------------	----------

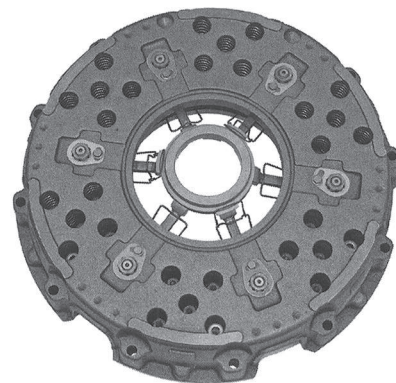

Clutch Cover & Clutch Disc

Druckplatte & Mitnehmerscheibe • Mécanisme & Disque d'Embrayage • Maza & Disco de Embrague
 Platô & Discô de Embreagem • Нажимной и ведомый диски

Application	Description	Details	Ref.	Erqo No.
BM 385 OM 401	EN Clutch cover, 350 mm DE Druckplatte, 350 mm FR Mécanisme d'embrayage, 350 mm ES Maza de embrague, 350 mm PT Platô, 350 mm RU Нажимной диск, 350 мм	repl. Sachs: 3482 051 131	004 250 2404	02.20394 

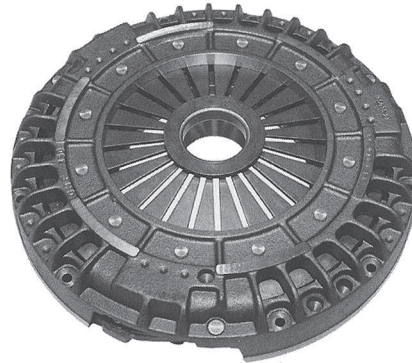

2

BM 617/619/620/621, 623/624/625, BM 385/387/389/393, 395	EN Clutch cover, 420mm DE Druckplatte, 420 mm FR Mécanisme d'embrayage, 420mm ES Maza de embrague, 420mm PT Platô, 420mm RU Нажимной диск, 420 мм	repl. Sachs: 1882 301 239	003 250 7004	02.20391 
---	--	---------------------------	--------------	--

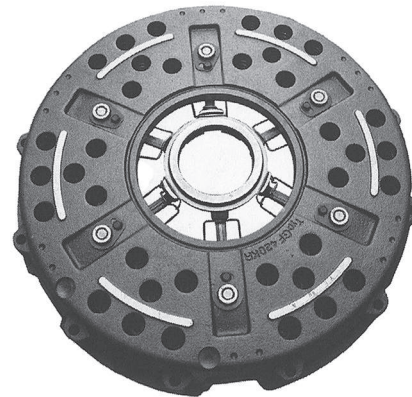

BM 395, BM 615/616/617/619, 621	EN Clutch cover, 430 mm DE Druckplatte, 430 mm FR Mécanisme d'embrayage, 430 mm ES Maza de embrague, 430 mm PT Platô, 430 mm RU Нажимной диск, 430 мм	repl. Sachs: 3482 124 541	003 250 3304	02.20388 
--	--	---------------------------	--------------	---

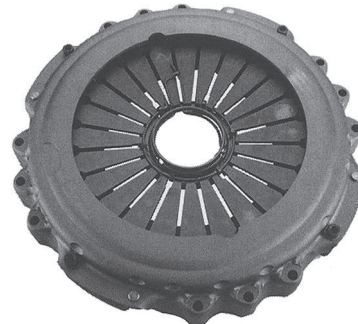

Sample

Clutch Cover & Clutch Disc

Druckplatte & Mitnehmerscheibe • Mécanisme & Disque d'Embrayage • Maza & Disco de Embrague
Platô & Discô de Embreagem • Нажимной и ведомый диски

Application	Description	Details	Ref.	Erqo No.
BM 620/621/622	<ul style="list-style-type: none"> EN Clutch cover, 420 mm DE Druckplatte, 420 mm FR Mécanisme d'embrayage, 420 mm ES Maza de embrague, 420 mm PT Platô, 420 mm RU Нажимной диск, 420 мм 	repl. Sachs: 1882 342 134	003 250 9004	02.20393

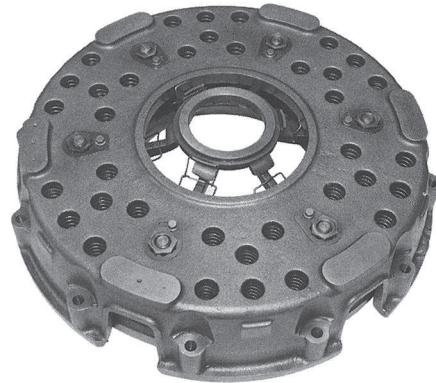

2

BM 625/650/651/652, 653/654/656/658, 659	<ul style="list-style-type: none"> EN Clutch cover, 430 mm DE Druckplatte, 430 mm FR Mécanisme d'embrayage, 430 mm ES Maza de embrague, 430 mm PT Platô, 430 mm RU Нажимной диск, 430 мм 	repl. Sachs: 3482 081 231	005 250 8404	02.20408
---	--	---------------------------	--------------	----------

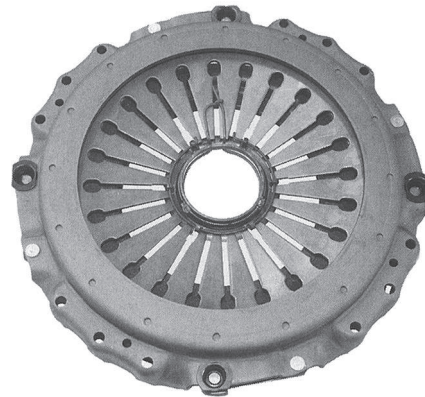



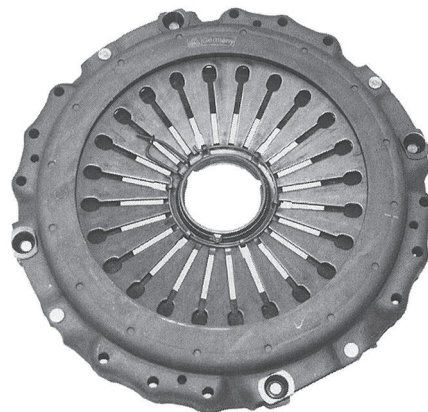



BM 625/650/651/652, 653/654/656/658, 659	<ul style="list-style-type: none"> EN Clutch cover, 430 mm DE Druckplatte, 430 mm FR Mécanisme d'embrayage, 430 mm ES Maza de embrague, 430 mm PT Platô, 430 mm RU Нажимной диск, 430 мм 	repl. Sachs: 3482 081 232	005 250 8304	02.20407
---	--	---------------------------	--------------	----------

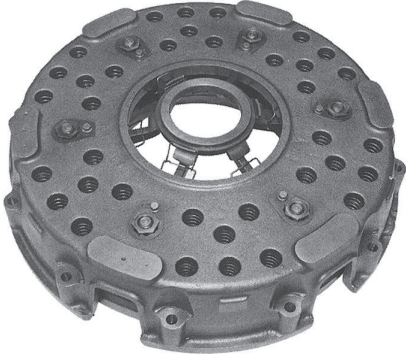

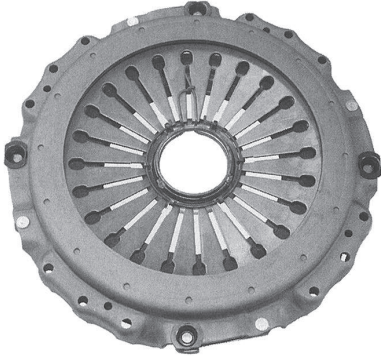
Clutch Cover & Clutch Disc

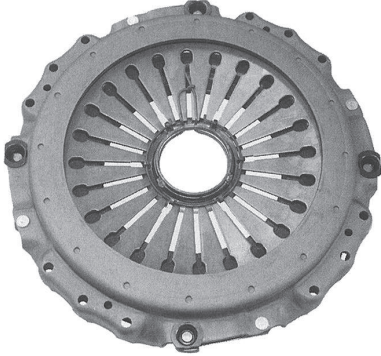
Druckplatte & Mitnehmerscheibe • Mécanisme & Disque d'Embrayage • Maza & Disco de Embrague
 Platô & Discô de Embreagem • Нажимной и ведомый диски

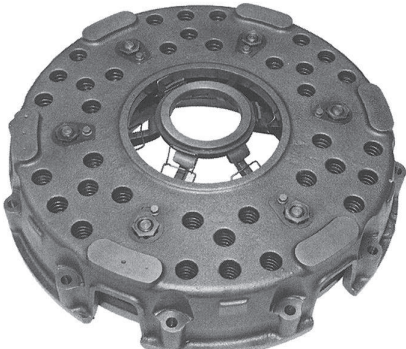
Application	Description	Details	Ref.	Erqo No.
BM 645/646/647/648/649	EN Clutch cover, 380 mm DE Druckplatte, 380 mm FR Mécanisme d'embrayage, 380 mm ES Maza de embrague, 380 mm PT Platô, 380 mm RU Нажимной диск, 380 мм	repl. Sachs: 1888 055 041	004 250 4104	02.20395 
				
		Sample		
BM 655/656/657/658/659	EN Clutch cover, 400 mm DE Druckplatte, 400 mm FR Mécanisme d'embrayage, 400 mm ES Maza de embrague, 400 mm PT Platô, 400 mm RU Нажимной диск, 400 мм	repl. Sachs: 3488 017 432	005 250 7704	02.20406 
				
		Sample		
BM 655/656/657/658/659	EN Clutch cover, 430 mm DE Druckplatte, 430 mm FR Mécanisme d'embrayage, 430 mm ES Maza de embrague, 430 mm PT Platô, 430 mm RU Нажимной диск, 430 мм	repl. Sachs: 3482 081 233	004 250 8904	02.20403 
				
		Sample		
BM 380/381/383/385, OM 401	EN Clutch disc, 350 mm DE Mitnehmerscheibe, 350 mm FR Disque d'embrayage, 350 mm ES Disco de embrague, 350 mm PT Disco embreagem, 350 mm RU Ведомый диск, 350 мм	repl. Sachs: 1878 001 070	007 250 7403	02.20311 
				

THE ORIGINAL NUMBERS OF THE VEHICLE MANUFACTURER MAY BE USED FOR COMPARISON PURPOSES ONLY AND MUST NOT BE MENTIONED ON INVOICES TO VEHICLE OWNERS.

Clutch Cover & Clutch Disc

Druckplatte & Mitnehmerscheibe • Mécanisme & Disque d'Embrayage • Maza & Disco de Embrague
Plató & Discó de Embreagem • Нажимной и ведомый диски

Application	Description	Details	Ref.	Erqo No.
-------------	-------------	---------	------	----------

BM
380/383/385/387,
389/393/395,
615/616/617/619,
621

- EN Clutch disc, 380 mm
- DE Mitnehmerscheibe, 380 mm
- FR Disque d'embrayage, 380 mm
- ES Disco de embrague, 380 mm
- PT Disco embreagem, 380 mm
- RU Ведомый диск, 380 мм

repl. Sachs: 1878 000 105

007 250 1003

02.20304

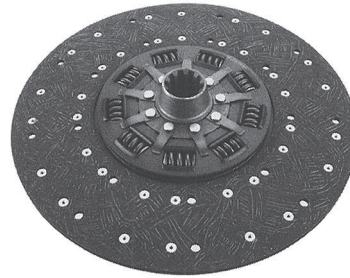

Sample

BM
385/387/389/393,
395,
617/619/620/621,
623/624/625

- EN Clutch disc, 420 mm
- DE Mitnehmerscheibe, 420 mm
- FR Disque d'embrayage, 420 mm
- ES Disco de embrague, 420 mm
- PT Disco embreagem, 420 mm
- RU Ведомый диск, 420 мм

repl. Sachs: 1861 410 046

007 250 4303

02.20306

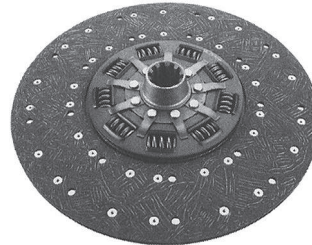

BM
620/621/622/623,
624

- EN Clutch disc, 420 mm
- DE Mitnehmerscheibe, 420 mm
- FR Disque d'embrayage, 420 mm
- ES Disco de embrague, 420 mm
- PT Disco embreagem, 420 mm
- RU Ведомый диск, 420 мм

repl. Sachs: 1861 760 034

008 250 7403

02.20315

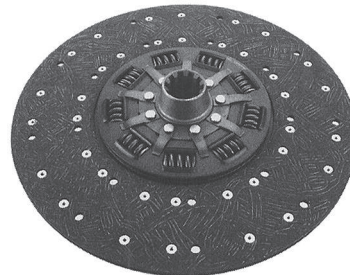

Sample

BM
624/625/646/648/649,
655/656/658/659

- EN Clutch disc, 380 mm
- DE Mitnehmerscheibe, 380 mm
- FR Disque d'embrayage, 380 mm
- ES Disco de embrague, 380 mm
- PT Disco embreagem, 380 mm
- RU Ведомый диск, 380 мм

repl. Sachs: 1862 305 033

009 250 0103

02.20317

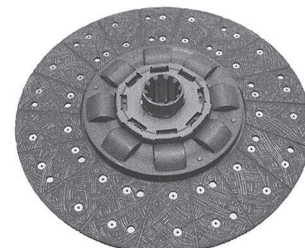

Sample

THE ORIGINAL NUMBERS OF THE VEHICLE MANUFACTURER MAY BE USED FOR COMPARISON PURPOSES ONLY AND MUST NOT BE MENTIONED ON INVOICES TO VEHICLE OWNERS.

Clutch Cover & Clutch Disc

Druckplatte & Mitnehmerscheibe • Mécanisme & Disque d'Embrayage • Maza & Disco de Embrague
 Platô & Discô de Embreagem • Нажимной и ведомый диски

Application	Description	Details	Ref.	Erqo No.
BM 624/625/645/648/649, 655/656/658/659	EN Clutch disc, 380 mm DE Mitnehmerscheibe, 380 mm FR Disque d'embrayage, 380 mm ES Disco de embrague, 380 mm PT Disco embreagem, 380 mm RU Ведомый диск, 380 мм	repl. Sachs: 1862 304 033	008 250 9703	02.20316 

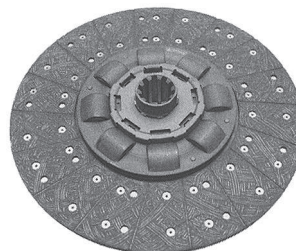

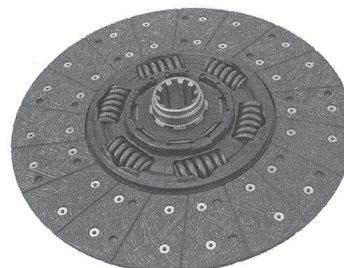

Sample

BM 625/650/652/653, 654/655/656/659	EN Clutch disc, 430 mm DE Mitnehmerscheibe, 430 mm FR Disque d'embrayage, 430 mm ES Disco de embrague, 430 mm PT Disco embreagem, 430 mm RU Ведомый диск, 430 мм	repl. Sachs: 1878 002 729	014 250 6803	02.20345 
---	---	---------------------------	--------------	---

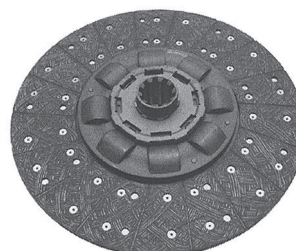

BM 625/652/655/656, 658/659	EN Clutch disc, 430 mm DE Mitnehmerscheibe, 430 mm FR Disque d'embrayage, 430 mm ES Disco de embrague, 430 mm PT Disco embreagem, 430 mm RU Ведомый диск, 430 мм	repl. Sachs: 1878 080 037	007 250 5903	02.20310 
-----------------------------------	---	---------------------------	--------------	---



BM 625/650/651/652, 653/654/656/659	EN Clutch disc, 430 mm DE Mitnehmerscheibe, 430 mm FR Disque d'embrayage, 430 mm ES Disco de embrague, 430 mm PT Disco embreagem, 430 mm RU Ведомый диск, 430 мм	repl. Sachs: 1862 216 032	011 250 0403	02.20327 
---	---	---------------------------	--------------	---

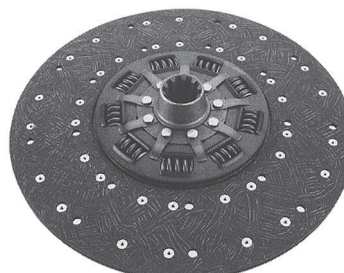

THE ORIGINAL NUMBERS OF THE VEHICLE MANUFACTURER MAY BE USED FOR COMPARISON PURPOSES ONLY AND MUST NOT BE MENTIONED ON INVOICES TO VEHICLE OWNERS.

Clutch Cover & Clutch Disc

Druckplatte & Mitnehmerscheibe • Mécanisme & Disque d'Embrayage • Maza & Disco de Embrague
 Platô & Discô de Embreagem • Нажимной и ведомый диски

Application	Description	Details	Ref.	Erqo No.
BM 645/646/647/648/649	<ul style="list-style-type: none"> EN Clutch disc, 380 mm DE Mitnehmerscheibe, 380 mm FR Disque d'embrayage, 380 mm ES Disco de embrague, 380 mm PT Disco embreagem, 380 mm RU Ведомый диск, 380 мм 	repl. Sachs: 1862 135 035	007 250 4703	02.20307

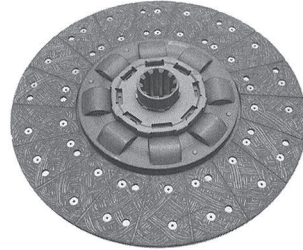

Sample

BM 645/646/647/648/649	<ul style="list-style-type: none"> EN Clutch disc, 380 mm DE Mitnehmerscheibe, 380 mm FR Disque d'embrayage, 380 mm ES Disco de embrague, 380 mm PT Disco embreagem, 380 mm RU Ведомый диск, 380 мм 	repl. Sachs: 1862 138 032	007 250 4903	02.20308
---------------------------	---	---------------------------	--------------	----------

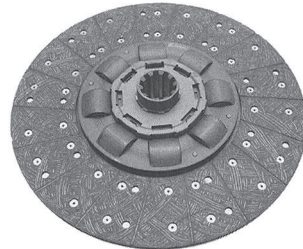

Sample

BM 645/655/656/658/659	<ul style="list-style-type: none"> EN Clutch disc, 380 mm DE Mitnehmerscheibe, 380 mm FR Disque d'embrayage, 380 mm ES Disco de embrague, 380 mm PT Disco embreagem, 380 mm RU Ведомый диск, 380 мм 	repl. Sachs: 1862 122 132	011 250 1703	02.20331
---------------------------	---	---------------------------	--------------	----------

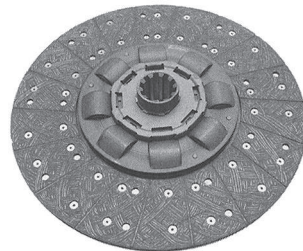

Sample

BM 645/655/656/658/659	<ul style="list-style-type: none"> EN Clutch disc, 380 mm DE Mitnehmerscheibe, 380 mm FR Disque d'embrayage, 380 mm ES Disco de embrague, 380 mm PT Disco embreagem, 380 mm RU Ведомый диск, 380 мм 	repl. Sachs: 1862 123 131	011 250 1303	02.20329
---------------------------	---	---------------------------	--------------	----------

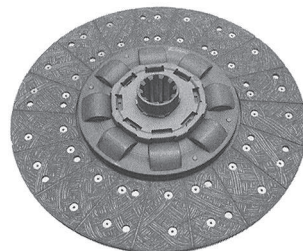





Sample

THE ORIGINAL NUMBERS OF THE VEHICLE MANUFACTURER MAY BE USED FOR COMPARISON PURPOSES ONLY AND MUST NOT BE MENTIONED ON INVOICES TO VEHICLE OWNERS.

Clutch Cover & Clutch Disc

Druckplatte & Mitnehmerscheibe • Mécanisme & Disque d'Embrayage • Maza & Disco de Embrague
 Platô & Discô de Embreagem • Нажимной и ведомый диски



Application	Description	Details	Ref.	Erqo No.
BM 652/653/654/656	EN Clutch disc, 430 mm DE Mitnehmerscheibe, 430 mm FR Disque d'embrayage, 430 mm ES Disco de embrague, 430 mm PT Disco embreagem, 430 mm RU Ведомый диск, 430 мм	repl. Sachs: 1878 080 033	019 250 3203	02.20372 
Sample				
BM 655/656/657/658/659	EN Clutch disc, 400 mm DE Mitnehmerscheibe, 400 mm FR Disque d'embrayage, 400 mm ES Disco de embrague, 400 mm PT Disco embreagem, 400 mm RU Ведомый диск, 400 мм	repl. Sachs: 1862 190 105	010 250 8903	02.20325 
BM 655/656/657/658/659	EN Clutch disc, 400 mm DE Mitnehmerscheibe, 400 mm FR Disque d'embrayage, 400 mm ES Disco de embrague, 400 mm PT Disco embreagem, 400 mm RU Ведомый диск, 400 мм	repl. Sachs: 1862 193 105	010 250 9203	02.20326 
BM 655/656/657/658/659	EN Clutch disc, 430 mm DE Mitnehmerscheibe, 430 mm FR Disque d'embrayage, 430 mm ES Disco de embrague, 430 mm PT Disco embreagem, 430 mm RU Ведомый диск, 430 мм	repl. Sachs: 1878 002 735	016 250 4003	02.20361 
Sample				

THE ORIGINAL NUMBERS OF THE VEHICLE MANUFACTURER MAY BE USED FOR COMPARISON PURPOSES ONLY AND MUST NOT BE MENTIONED ON INVOICES TO VEHICLE OWNERS.

Clutch Cover & Clutch Disc

Druckplatte & Mitnehmerscheibe • Mécanisme & Disque d'Embrayage • Maza & Disco de Embrague
Plató & Discó de Embreagem • Нажимной и ведомый диски

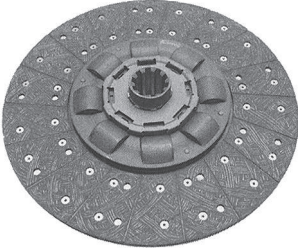
2

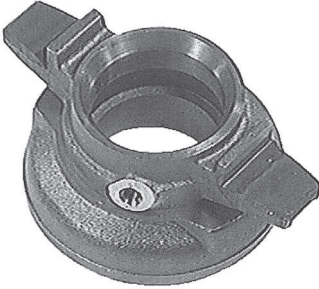
Application	Description	Details	Ref.	Erqo No.
SA 082742, SA 082949	<ul style="list-style-type: none"> EN Clutch disc, 420 mm DE Mitnehmerscheibe, 420 mm FR Disque d'embrayage, 420 mm ES Disco de embrague, 420 mm PT Disco embreagem, 420 mm RU Ведомый диск, 420 мм 	repl. Sachs: 1861 410 047	010 250 0203	02.20320 
				Sample
BM 380/383/385/387, 389/393/395, 615/616/617/619, 620/621/623/624, 625	<ul style="list-style-type: none"> EN Release bearing DE Ausrücklager FR Butée d'embrayage ES Cojinete de embrague PT Mancaí embreagem RU Выжимной подшипник 	repl. Sachs: 3151 027 131	000 250 7415	02.20420 
				
BM 381/383/385, 616/617	<ul style="list-style-type: none"> EN Release bearing DE Ausrücklager FR Butée d'embrayage ES Cojinete de embrague PT Mancaí embreagem RU Выжимной подшипник 	repl. Sachs: 3151 044 031	001 250 9315	02.20438 
				
BM 615/616/617/619	<ul style="list-style-type: none"> EN Release bearing DE Ausrücklager FR Butée d'embrayage ES Cojinete de embrague PT Mancaí embreagem RU Выжимной подшипник 	repl. Sachs: 3151 108 031	000 250 7615	02.20422 
				
BM 617/619/623	<ul style="list-style-type: none"> EN Release bearing DE Ausrücklager FR Butée d'embrayage ES Cojinete de desembrague PT Mancaí embreagem RU Выжимной подшипник 	repl. Sachs: 3151 182 031	001 250 4515	02.20427 
				

THE ORIGINAL NUMBERS OF THE VEHICLE MANUFACTURER MAY BE USED FOR COMPARISON PURPOSES ONLY AND MUST NOT BE MENTIONED ON INVOICES TO VEHICLE OWNERS.

Clutch Cover & Clutch DiscDruckplatte & Mitnehmerscheibe • Mécanisme & Disque d'Embrayage • Maza & Disco de Embrague
Platô & Discô de Embragem • Нажимной и ведомый диски

Application	Description	Details	Ref.	Erqo No.
BM 620/621/622/623, 624	<ul style="list-style-type: none"> EN Release bearing DE Ausrücklager FR Butée d'embrayage ES Cojinete de embrague PT Mancai embreagem RU Выжимной подшипник 	repl. Sachs: 3151 110 031	000 250 7315	02.20419 
BM 620/621/622/623, 624/625, 645/646/647/648, 649	<ul style="list-style-type: none"> EN Release bearing DE Ausrücklager FR Butée d'embrayage ES Cojinete de embrague PT Mancai embreagem RU Выжимной подшипник 	repl. Sachs: 3151 108 031	000 250 7515	02.20421 
BM 625, 650/651/652/653, 654/655/656/658, 659	<ul style="list-style-type: none"> EN Release bearing DE Ausrücklager FR Butée d'embrayage ES Cojinete de embrague PT Mancai embreagem RU Выжимной подшипник 	repl. Sachs: 3151 246 031	001 250 9815	02.20440 
BM 625/650/651/652, 653/654/655/656, 658/659	<ul style="list-style-type: none"> EN Release bearing DE Ausrücklager FR Butée d'embrayage ES Cojinete de embrague PT Mancai embreagem RU Выжимной подшипник 	repl. Sachs: 3151 245 032	001 250 9715	02.20439 
BM 625/652/655/656/658, 659	<ul style="list-style-type: none"> EN Release bearing DE Ausrücklager FR Butée d'embrayage ES Cojinete de desembrague PT Mancai embreagem RU Выжимной подшипник 	repl. Sachs: 3151 166 031	000 250 9215	02.20424 





Sample

THE ORIGINAL NUMBERS OF THE VEHICLE MANUFACTURER MAY BE USED FOR COMPARISON PURPOSES ONLY AND MUST NOT BE MENTIONED ON INVOICES TO VEHICLE OWNERS.

Application	Description	Details	Ref.	Erqo No.
BM 381/383/385/387/389, 393/395, BM 616/617/619/620/621/ 622/623/624/625, BM 645/646/647/648/649	(EN) Screw in fitting (DE) Einschraubstutzen (FR) Raccord vis (ES) Racor roscado (PT) Conexão (RU) Винчиваемый штуцер		071428 004102	02.22888 
BM 616/617/619, 621/624	(EN) Spring (DE) Feder (FR) Ressort (ES) Muelle (PT) Mola (RU) Пружина		620 993 0125	02.22559 
BM 383/385/387/389, 393/395, BM 616/617/619/620/ 621/622/623/624/625	(EN) Spring (DE) Druckfeder (FR) Ressort (ES) Resorte de compresión (PT) Mola espiral (RU) Пружина, диаметр	Ø 4,00 mm	000 252 4420	02.20446 
BM 383/385/387/389, 393/395, BM 616/617/619/620/ 621/622/623/624/625	(EN) Spring (DE) Feder (FR) Ressort (ES) Muelle (PT) Mola espiral (RU) Пружина, диаметр	Ø 3,75 mm	000 252 4320	02.20445 
BM 383/385/387/389, 393/395, 615/616/617/619 --chassis 5234953	(EN) Release ring (DE) Ausrückring (FR) Bague de débrayage (ES) Anillo de desembrague (PT) Anel mancai (RU) Выжимное кольцо	70,3 x 99 x 18	000 252 2145	02.20449 
BM 385/387/389, 391/393/395/398, 616/617/619, 620/621/623/624, 625 chassis 5234954--	(EN) Release ring (DE) Ausrückring (FR) Bague de débrayage (ES) Anillo de desembrague (PT) Anel mancai (RU) Кольцо выключения сцепления	78,2 x 110 x 18	000 252 1245	02.20448 

Clutch Cover & Clutch Disc

Druckplatte & Mitnehmerscheibe • Mécanisme & Disque d'Embrayage • Maza & Disco de Embrague
 Platô & Discô de Embreagem • Нажимной и ведомый диски



Application	Description	Details	Ref.	Erqo No.
BM 620/621/623/624 (1633/1933/2233 /2633) --chassis 4766727	EN Release ring DE Ausrückring FR Bague de débrayage ES Anillo de desembrague PT Anel mancai RU Выжимное кольцо	Ø 78,2 / 110,0	000 252 1145	02.20447 
BM 620/621/622/623, 624, chassis 4766728--	EN Release ring DE Ausrückring FR Bague de débrayage ES Anillo de desembrague PT Anel mancai RU Выжимное кольцо	Ø 78,3 / 109,0	000 252 2345	02.20450 
BM 620/621/623/624 (380 PS), 645/646/647/648, 649	EN Release ring DE Ausrückring FR Bague de débrayage ES Anillo de desembrague PT Anel mancai RU Кольцо выключения сцепления		000 252 2445	02.20451 
BM 625, 650/651/652/653, 654/655/656/657, 658/659	EN Release ring DE Ausrückring FR Bague de débrayage ES Anillo de desembrague PT Anel mancai RU Выжимное кольцо	repl. Sachs: 3496 005 000	000 252 0346	02.20452 
BM 650/651/652/653, 654/655/656/657, 658/659	EN Release ring DE for pressure plate 4.62802 FR Ausrückring für Druckplatte 4.62802 ES Bague de débrayage PT Anillo de desembrague Anel mancai RU Кольцо выключения сцепления	repl. Sachs: 3496 006 000	000 252 0646	02.20453 

THE ORIGINAL NUMBERS OF THE VEHICLE MANUFACTURER MAY BE USED FOR COMPARISON PURPOSES ONLY AND MUST NOT BE MENTIONED ON INVOICES TO VEHICLE OWNERS.









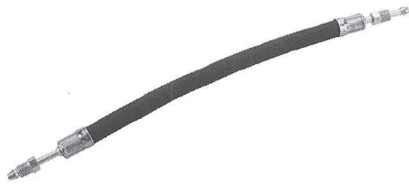

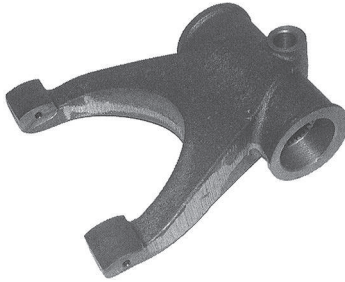
Clutch Cover & Clutch Disc

Druckplatte & Mitnehmerscheibe • Mécanisme & Disque d'Embrayage • Maza & Disco de Embrague
 Platô & Discô de Embreagem • Нажимной и ведомый диски

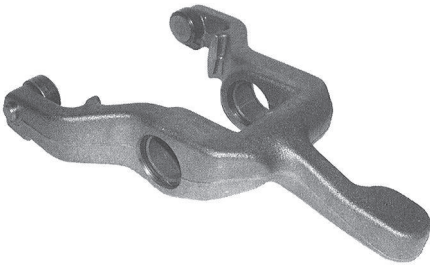
2

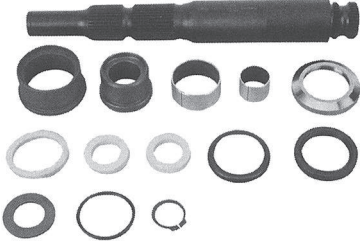
Application	Description	Details	Ref.	Erqo No.
BM 381/383/385/387/389, 393/395, BM 616/617/619, BM 620/621/622/623/ 624/625, BM 645/646/647/648/649	<ul style="list-style-type: none"> EN Hose DE Schlauch FR Durite ES Tubo flexible PT Flexível RU Шланг 	L: 250 mm	385 997 0582	02.22765 
BM 616/617/619, BM 621, 624	<ul style="list-style-type: none"> EN Hose line DE Schlauchleitung FR Durite droite ES Tubería flexible PT Flexível RU Шлангопровод 	L: 285 mm	000 573 2636	02.22060 



Application	Description	Details	Ref.	Erqo No.
BM 381/383/385/387, 389/391/393, 615/616/617/619, 620/621/623/624, 645/646/647/648, 649	<ul style="list-style-type: none"> EN Release lever DE Ausrückhebel FR Levier de butée ES Horquilla de embrague PT Garfo embreagem RU Рычаг выключения сцепления 		620 254 0108	02.20456 
BM 383/385/387/389, 391/393/395/397, 615/616/617/619, 620/621/622/623, 624/625, 650.282	<ul style="list-style-type: none"> EN Release lever DE Ausrückhebel FR Levier de butée ES Horquilla de embrague PT Garfo embreagem RU Рычаг выключения сцепления 		000 252 4613	02.20444 
BM 625, 650/651/652/653, 654/655/656/657, 658/659	<ul style="list-style-type: none"> EN Release lever DE Ausrückhebel FR Levier de butée ES Horquilla de embrague PT Garfo embreagem RU Рычаг выключения сцепления 		650 250 3813	02.20411 
380/381/383/385, 387/389, 391/393/395/398, 615/616/617/619, 620/621/623/624, 625 645/646/647/648, 649	<ul style="list-style-type: none"> EN Repair kit, release shaft DE Reparatursatz, Ausrückwelle FR Kit de réparation, arbre débrayage ES Kit de reparación, Árbol de desembrague PT Jogo reparo, eixo embreagem RU Ремонтный комплект, Вал выключения сцепления 		385 250 0014	02.20412 
BM 615/616/617/619, 621/624 chassis--	<ul style="list-style-type: none"> EN Repair kit DE Reparatursatz FR Kit de réparation ES Kit de reparación PT Jogo reparo RU Ремонтный комплект 		620 250 0214	02.20414 

THE ORIGINAL NUMBERS OF THE VEHICLE MANUFACTURER MAY BE USED FOR COMPARISON PURPOSES ONLY AND MUST NOT BE MENTIONED ON INVOICES TO VEHICLE OWNERS.

Application	Description	Details	Ref.	Erqo No.
BM 625, 650/651/652/653, 654/655/656/657, 658/659	<ul style="list-style-type: none"> EN Repair kit DE Reparatursatz FR Kit de réparation ES Kit de reparación PT Jogo reparo RU Ремонтный комплект 		650 250 0214	02.23167 
BM 615/616/617/619, 621/624 chassis-	<ul style="list-style-type: none"> EN Shaft DE Welle FR Arbre ES Eje PT Eixo RU Вал 		620 254 0207	02.23166 
BM 625, 650/651/652/653, 654/655/656/657, 658/659	<ul style="list-style-type: none"> EN Shaft DE Welle FR Arbre ES Eje PT Eixo RU Вал 		650 254 0006	02.20454 
BM 615/616/617/619, 621/624 chassis --	<ul style="list-style-type: none"> EN Needle bearing DE Nadellager FR Roulement à aiguilles ES Rodamiento de agujas PT Rolamento agulha RU Игольчатый подшипник 	repl. INA HK 3016	009 981 0410	02.22372 
BM 616/617/619, 621/624/625, 652/653/654/655, 656/657/658/659	<ul style="list-style-type: none"> EN Screw DE Schraube FR Vis ES Tornillo PT Parafuso RU Болт 	M 10 x 45	914112 010025	02.22963 
BM 625, 650/651/652/653, 654/655/656/657, 658/659	<ul style="list-style-type: none"> EN Bushing DE Buchse FR Bague ES Casquillo PT Bucha RU Втулка 		001 992 8401	02.22531 







Application	Description	Details	Ref.	Erqo No.
BM 625, 650/651/652/653, 654/655/656/657, 658/659	<ul style="list-style-type: none"> EN Repair kit, clutch lever DE Reparatursatz, Ausrückhebel FR Kit de réparation, Levier de débrayage ES Kit de reparación, Horquilla de embrague PT Jogo reparo, Garfo embreagem RU Ремонтный комплект, Рычаг выключения сцепления 		655 250 0069 S	02.23168 
BM 625, 650/651/652/653, 654/655/656/657, 658/659	<ul style="list-style-type: none"> EN Roller, clutch lever DE Rolle, Kupplungshebel FR Rouleau, Levier d'embrayage ES Rodillo, Horquilla de embrague PT Rolamento, regulagem embreagem RU Ролик, Рычаг выключения сцепления 		655 250 0069	02.20443 
BM 625, 650/651/652/653, 654/655/656/657, 658/659	<ul style="list-style-type: none"> EN Pin, clutch lever DE Bolzen, Kupplungshebel FR Boulon, Levier d'embrayage ES Bulón, Horquilla de embrague PT Pino, regulagem embreagem RU Болт, Рычаг выключения сцепления 		650 254 0474	02.20458 
BM 381/383/385/387, 389/393/395, 616/617/619/620, 621/622/623/624, 625/647	<ul style="list-style-type: none"> EN Repair kit, lever DE Reparatursatz, Hebel FR Kit de réparation, levier ES Juego reparación, palanca PT Jogo reparo, garfo RU Ремонтный комплект, Рычаг 		620 290 0534	02.20726 
BM 620/621/622/623, 624, 645/646/647/648, 649	<ul style="list-style-type: none"> EN Repair kit, lever DE Reparatursatz, Hebel FR Kit de réparation, levier ES Juego reparación, palanca PT Jogo reparo, garfo RU Ремонтный комплект, Рычаг 		620 290 0434	02.20725 

THE ORIGINAL NUMBERS OF THE VEHICLE MANUFACTURER MAY BE USED FOR COMPARISON PURPOSES ONLY AND MUST NOT BE MENTIONED ON INVOICES TO VEHICLE OWNERS.









Release Lever

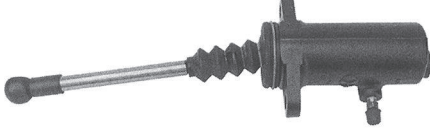



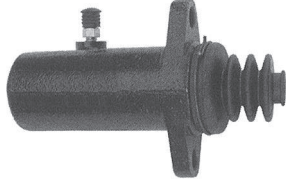

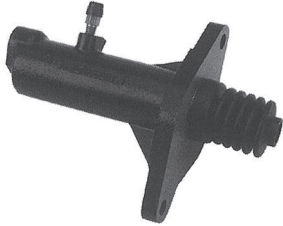

Ausrückhebel • Levier de Butée • Horquilla de Embrague
 Alavanca Embreagem • вилка сцепления

2



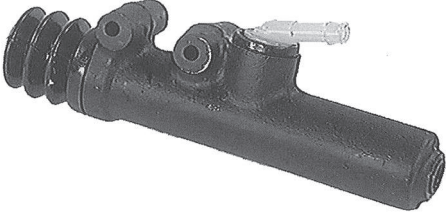



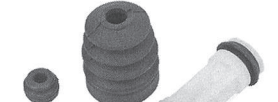

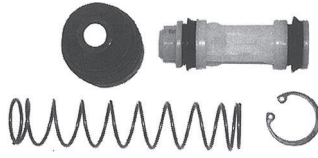

Application	Description	Details	Ref.	Erqo No.
BM 617/625/650/651, 652/655/656/658, 659	EN Bearing DE Lager FR Palier ES Cojinete PT Rolamento garfo embreagem RU Подшипник		000 254 0335	02.20457 
BM 617/625/650/651, 652/655/656/658, 659	EN Bolt DE Bolzen FR Axe ES Bulón PT Pino RU Болт		645 295 0274	02.20767 
BM 381/383/385/387/389, 393/395, BM 616/617/619/620/621/ 622/623/624/625, BM 645/646/647/648/649	EN Spring DE Feder FR Ressort ES Muelle PT Mola RU Пружина		317 993 0225	02.22558 

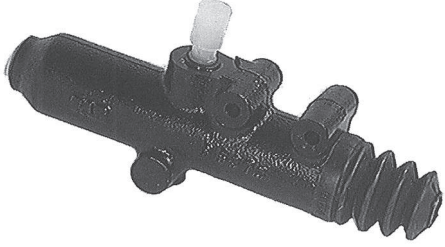
THE ORIGINAL NUMBERS OF THE VEHICLE MANUFACTURER MAY BE USED FOR COMPARISON PURPOSES ONLY AND MUST NOT BE MENTIONED ON INVOICES TO VEHICLE OWNERS.



Application	Description	Details	Ref.	Erqo No.
BM 381/383/385, 616/617	<ul style="list-style-type: none"> EN Clutch cylinder DE Kupplungszyylinder FR Cylindre émetteur ES Cilindro de embrague PT Cilindro hidráulico RU Рабочий цилиндр сцепления 		000 295 7207	02.20750 
BM 381/383/385, 616/617	<ul style="list-style-type: none"> EN Repair kit, clutch cylinder DE Reparatursatz, Kupplungszyylinder FR Kit de réparation, cylindre émetteur ES Kit de reparación, Cilindro de embrague PT Jogo reparo, cilindro embreagem RU Ремонтный комплект, Рабочий цилиндр сцепления 		000 290 0811	02.20709 
BM 385/387/389, 393, 615/616/617/619; BM 621/622/624 --chassis	<ul style="list-style-type: none"> EN Clutch cylinder DE Kupplungszyylinder FR Emetteur d'embrayage ES Cilindro de embrague PT Cilindro embreagem RU Рабочий цилиндр сцепления 		002 295 0407	02.20753 
BM 385/387/389, 393, BM 615/616/617/619, 621/622/624 --chassis	<ul style="list-style-type: none"> EN Repair kit, clutch cylinder DE Reparatursatz, Kupplungszyylinder FR Kit de réparation, cylindre émetteur ES Kit de reparación, Cilindro de embrague PT Jogo reparo, cilindro embreagem RU Ремонтный комплект, Рабочий цилиндр сцепления 		000 290 0911	02.20710 
BM 385/387/389, 393, BM 615/616/617/619, 621/622/624 --chassis	<ul style="list-style-type: none"> EN Repair kit, clutch cylinder DE Reparatursatz, Kupplungszyylinder FR Kit de réparation, cylindre émetteur ES Kit de reparación, Cilindro de embrague PT Jogo reparo, cilindro embreagem RU Ремонтный комплект, Рабочий цилиндр сцепления 		000 586 3129	02.22072 

Application	Description	Details	Ref.	Erqo No.
BM 615/616/617/619, 621/624 chassis--	<ul style="list-style-type: none"> EN Clutch cylinder DE Kupplungszyylinder FR Cylindre émetteur ES Cilindro de embrague PT Cilindro embreagem RU Рабочий цилиндр сцепления 		001 295 4407	02.20751 
BM 615/616/617/619, 621/624 chassis--	<ul style="list-style-type: none"> EN Repair kit DE Reparatursatz FR Kit de réparation ES Kit de reparación PT Jogo reparo RU Ремонтный комплект 		000 290 4067	02.20732 
BM 380/383/385, 387/389/393, 616/617/619, 620/621/623, 624/625, 646/649	<ul style="list-style-type: none"> EN Clutch cylinder DE Kupplungszyylinder FR Cylindre émetteur ES Cilindro de embrague PT Cilindro mestre embreagem RU Рабочий цилиндр сцепления 		001 295 6006	02.20745 
BM 380/383/385, 387/389/393, 616/617/619, 620/621/623, 624/625, 646/649	<ul style="list-style-type: none"> EN Repair kit, clutch cylinder DE Reparatursatz, Kupplungszyylinder FR Kit de réparation, cylindre émetteur ES Kit de reparación, Cilindro de embrague PT Jogo reparo, cilindro embreagem RU Ремонтный комплект, Рабочий цилиндр сцепления 		000 586 3529	02.22073 
BM 380/383/385, 387/389/393, 616/617/619, 620/621/623, 624/625, 646/649	<ul style="list-style-type: none"> EN Repair kit, clutch cylinder DE Reparatursatz, Kupplungszyylinder FR Kit de réparation, cylindre émetteur ES Kit de reparación, Cilindro de embrague PT Jogo reparo, cilindro embreagem RU Ремонтный комплект, Рабочий цилиндр сцепления 		000 290 4667	02.20733 

THE ORIGINAL NUMBERS OF THE VEHICLE MANUFACTURER MAY BE USED FOR COMPARISON PURPOSES ONLY AND MUST NOT BE MENTIONED ON INVOICES TO VEHICLE OWNERS.

Application	Description	Details	Ref.	Erqo No.
BM 380/383/385, 387/389/393, 616/617/619, 620/621/623, 624/625, 646/649	<ul style="list-style-type: none"> EN Repair kit DE Reparatursatz FR Kit de réparation ES Kit de reparación PT Jogo reparo RU Ремонтный комплект 		000 290 3412	02.20715 
BM 620/621/623/624 (380 PS); BM 645/646, 647/648/649	<ul style="list-style-type: none"> EN Clutch cylinder DE Kupplungszyylinder FR Cylindre émetteur ES Cilindro de embrague PT Cilindro mestre embreagem RU Рабочий цилиндр сцепления 		001 295 3006	02.20744 
BM 620/621/623/624 (380 PS); BM 645/646, 647/648/649	<ul style="list-style-type: none"> EN Repair kit, clutch cylinder DE Reparatursatz, Kupplungszyylinder FR Kit de réparation, cylindre émetteur ES Kit de reparación, Cilindro de embrague PT Jogo reparo, cilindro embreagem RU Ремонтный комплект, Рабочий цилиндр сцепления 		000 586 6029	02.22075 
BM 650/651/652, 653/654/655, 656/657/658, 659 chassis K011864--	<ul style="list-style-type: none"> EN Clutch cylinder DE Kupplungszyylinder FR Cylindre émetteur ES Cilindro de embrague PT Cilindro mestre embreagem RU Рабочий цилиндр сцепления 		001 295 7406	02.20749 
BM 650/651/652, 653/654/655, 656/657/658, 659 --chassis	<ul style="list-style-type: none"> EN Repair kit, clutch cylinder DE Reparatursatz, Kupplungszyylinder FR Kit de réparation, cylindre émetteur ES Kit de reparación, Cilindro de embrague PT Jogo reparo, cilindro embreagem RU Ремонтный комплект, Рабочий цилиндр сцепления 		000 290 1212	02.20712 





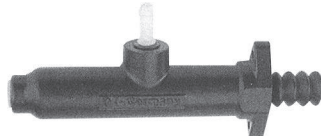





THE ORIGINAL NUMBERS OF THE VEHICLE MANUFACTURER MAY BE USED FOR COMPARISON PURPOSES ONLY AND MUST NOT BE MENTIONED ON INVOICES TO VEHICLE OWNERS.

Application	Description	Details	Ref.	Erqo No.
BM 651.012/0147016/017, 651.026/027/115/212, 651.315, 652, 653.011/012/014, 653.411/412.414, 654.411, 655.093/096/190-193, 655.490/492/494/496, 655.590-593, 656.091-096, 656.190/192, 657.580/585, 658.050/051/053, 658.054/190, 659.093/098/191/196 --chassis K011863	EN Clutch cylinder DE Kupplungszyylinder FR Cylindre émetteur ES Cilindro maestro PT Cilindro mestre embreagem RU Рабочий цилиндр сцепления		001 295 7006	02.20746 
BM 651.012/014/016/017, 651.026/027/115/212, 651.315, 652, 653.011/012/014, 653.411/412.414, 654.411, 655.093/096/190-193, 655.490/492/494/496, 655.590-593, 656.091-096, 656.190/192, 657.580/585, 658.050/051/053, 658.054/190, 659.093/098/191/196 --chassis K011863	EN Repair kit, clutch cylinder DE Reparatursatz, Kupplungszyylinder FR Kit de réparation, cylindre émetteur ES Juego reparación, Cilindro maestro PT Kit reparo , cilindro embreagem RU Ремонтный комплект		000 290 1312	02.20713 
BM 625.196/197, 651.121/122, 652.043/045-047, 652.141/142, 652.161/162/163, 654.155/426-428, 654.432/433/555, 655.316/317, 655.501-503/508, 655.541-543/548, 656.142/302/214, 656.215/312/316/317, 659.101/301	EN Clutch cylinder DE Kupplungszyylinder FR Cylindre émetteur ES Cilindro maestro PT Cilindro mestre embreagem RU Рабочий цилиндр сцепления		001 295 7206	02.20748 

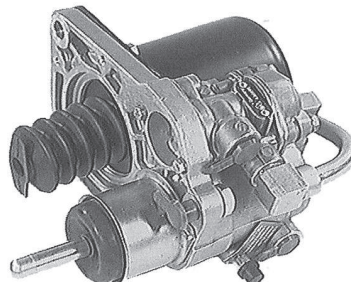

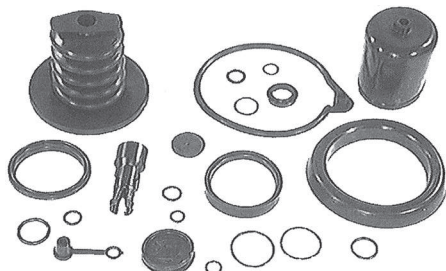



Application	Description	Details	Ref.	Erqo No.
BM 625.196/197, 651.121/122, 652.043/045-047, 652.141/142, 652.161/162/163, 654.155/426-428, 654.432/433/555, 655.316/317, 655.501-503/508, 655.541-543/548, 656.142/302/214, 656.215/312/316/317, 659.101/301	<ul style="list-style-type: none"> EN Repair kit, clutch cylinder DE Reparatursatz, Kupplungszyylinder FR Kit de réparation, cylindre émetteur ES Juego reparación, Cilindro maestro PT Kit reparo, cilindro embragem RU Ремонтный комплект Рабочий цилиндр сцепления 		000 290 1112	02.20711 
BM 380/381/383/385, 387/389, 391/393/395/398, 615/616/617/619, 620/621/622/623, 624/625, 645/646/647/648, 649	<ul style="list-style-type: none"> EN Reservoir DE Behälter FR Reservoir ES Depósito PT Reservatório RU Бачок 		000 295 1715	02.20754 
BM 625, 650/651/652/653, 654/655/656/657, 658/659	<ul style="list-style-type: none"> EN Reservoir DE Behälter FR Réservoir ES Depósito PT Reservatório RU Бачок 		655 295 0015	02.20755 
BM 380/381/383/385, 387/389, 390/391/393/395, 398, 620/621/622/623, 624/625	<ul style="list-style-type: none"> EN Link rod DE Gelenkstange FR Tringlerie de direction ES Barra articulada PT Tirante RU Шарнирный рычаг 		000 996 6440	02.22570 
NG/MK/SK	<ul style="list-style-type: none"> EN Repair kit DE Reparatursatz FR Kit de réparation ES Kit de reparación PT Jogo reparo RU Ремонтный комплект 			02.22570 





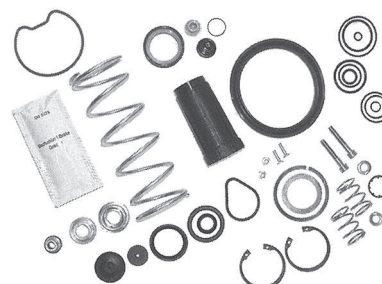
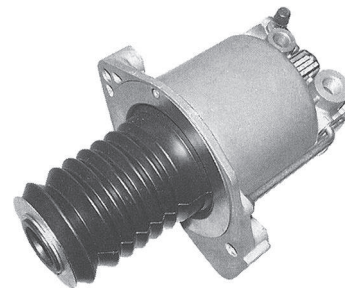

THE ORIGINAL NUMBERS OF THE VEHICLE MANUFACTURER MAY BE USED FOR COMPARISON PURPOSES ONLY AND MUST NOT BE MENTIONED ON INVOICES TO VEHICLE OWNERS.

Application	Description	Details	Ref.	Erqo No.
NG/MK/SK	<ul style="list-style-type: none"> EN Articulation piece DE Gelenkstück FR Pièce d'articulation ES Pieza articulada PT Articulação RU Шарнирный элемент 		000 996 1045	02.22572 
NG/MK/SK	<ul style="list-style-type: none"> EN Valve DE Ventil FR Soupape ES Válvula PT Válvula servo embreagem RU Клапан 		307 553 0107	02.22053 
BM 620/621/622/623, 624, 645/646/647/648	<ul style="list-style-type: none"> EN Clutch servo DE Kupplungsservo FR Servo d'embrayage ES Servoembrague PT Servo embreagem RU Пневмогидроусилитель 	repl. Wabco 970 051 131 0 	001 295 6707	02.20752 
BM 620/621/622/623, 624, 645/646/647/648	<ul style="list-style-type: none"> EN Repair kit DE Reparatursatz FR Kit de réparation ES Kit de reparación PT Jogo reparo RU Ремонтный комплект 	repl. Wabco 970 051 903 2 	000 290 0667	02.20730 
BM 620/621/622/623, 624, 645/646/647/648	<ul style="list-style-type: none"> EN Link DE Gelenkstange FR Tringlerie de direction ES Barra articulada PT Tirante RU Шарнирный рычаг 		000 996 7640	02.22571 

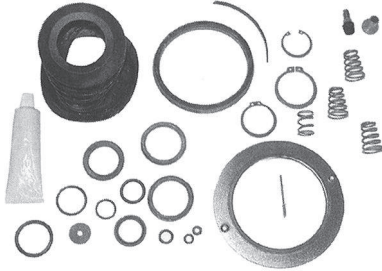
THE ORIGINAL NUMBERS OF THE VEHICLE MANUFACTURER MAY BE USED FOR COMPARISON PURPOSES ONLY AND MUST NOT BE MENTIONED ON INVOICES TO VEHICLE OWNERS.

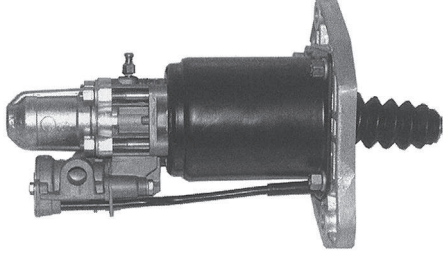
Application	Description	Details	Ref.	Erqo No.
BM 620/621/622/623, 624, 645/646/647/648	<ul style="list-style-type: none"> EN Bracket DE Halter FR Support ES Sujeción PT Suporte RU Кронштейн 		620 295 0240	02.20766 
BM 625 653.070-079, 659.000/030	<ul style="list-style-type: none"> EN Clutch servo DE Kupplungsservo FR Servo d'embrayage ES Servoembrague PT Servo embreagem RU Пневмогидроусилитель 	repl. Wabco 970 051 158 0	000 295 1518	02.20760 
BM 651/652/653/654, 655/656/657/658, 659	<ul style="list-style-type: none"> EN Clutch servo DE Kupplungsservo FR Servo d'embrayage ES Servoembrague PT Servo embreagem RU Пневмогидроусилитель 	repl. Wabco 970 051 147 0	000 295 0918	02.20758 
BM 625, 651/652/653/654, 655/656/657/658, 659	<ul style="list-style-type: none"> EN Repair kit DE Reparatursatz FR Kit de réparation ES Kit de reparación PT Jogo reparo RU Ремонтный комплект 	repl. Wabco 970 051 916 2	000 290 0347	02.20727 

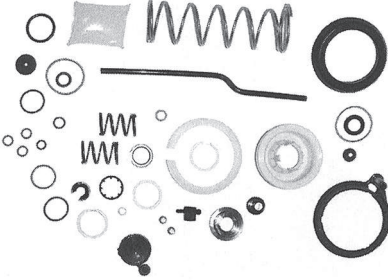

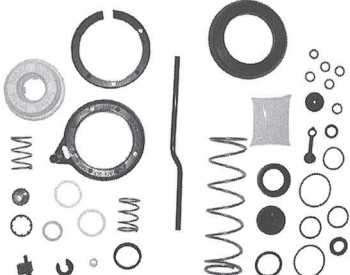
Application	Description	Details	Ref.	Erqo No.
BM 651/652/653/654, 655/656/657/658, 659	<ul style="list-style-type: none"> EN Repair kit, clutch servo DE Reparatursatz, Kupplungsservo FR Kit de réparation, servo embrayage ES Kit de reparación, Servoembrague PT Jogo reparo, servo embreagem RU Ремонтный комплект, Пневмогидроусилитель 	repl. Knorr II14195008	000 290 1047	02.20729 
				
BM 650/651/652/653, 654/655/656/659 -- 270PS	<ul style="list-style-type: none"> EN Clutch servo DE Kupplungsservo FR Servo d'embrayage ES Servoembrague PT Servo embreagem RU Пневмогидроусилитель 	repl. Wabco 970 051 151 0	000 295 0818	02.20757 
				
BM 650/651/652/653, 654/655/656/659 -- 270PS	<ul style="list-style-type: none"> EN Repair kit, clutch servo DE Reparatursatz, Kupplungsservo FR Kit de réparation, servo embrayage ES Kit de reparación, servoembrague PT Jogo reparo, servo embreagem RU Ремонтный комплект, Пневмогидроусилитель 	repl. Wabco 970 051 910 2	000 290 0647	02.20728 
				
BM 958.070/072, 958.074/076	<ul style="list-style-type: none"> EN Repair kit, clutch servo DE Reparatursatz, Kupplungsservo FR Kit de réparation, servo embrayage ES Kit de reparación, Servoembrague PT Jogo reparo, servo embreagem RU Ремонтный комплект, Пневмогидроусилитель 	repl. Wabco 970 051 917 2	000 250 0362	02.20442 
				

THE ORIGINAL NUMBERS OF THE VEHICLE MANUFACTURER MAY BE USED FOR COMPARISON PURPOSES ONLY AND MUST NOT BE MENTIONED ON INVOICES TO VEHICLE OWNERS.

Gear Shift LeverSchalthebel • Levier de Vitesses • Palanca del cambio
Manopla alavanca ex. mudança • Рычаг переключения

Application	Description	Details	Ref.	Erqo No.
BM 381/383/385/387, 389/391/393/395, 615/616/617/619, 620/621/622/623, 624/625/652/653, 654/655/656/659	<ul style="list-style-type: none"> EN Gear shift knob DE Schaltknäuf FR Pommeau de levier de vitesses ES Pomo de la palanca de cambios PT Manopla alavanca RU Рукоятка рычага переключения 		620 268 0042	02.20658 
BM 617/619/620/621, 622/623/624/625, 645/646/648/649, 652/653/655/656, 658/659	<ul style="list-style-type: none"> EN Gearshift knob DE Schaltknäuf FR Pommeau de levier de vitesses ES Pomo de la palanca de cambios PT Manopla alavanca RU Рукоятка рычага переключения 		620 260 0040	02.20461 
BM 381/383/385/387, 389/391/393/395, 615/616/617/619, 620/621/622/623, 624/625/645/646, 648/649/652/653, 655/656/658/659	<ul style="list-style-type: none"> EN Cover, neutral DE Abdeckung, neutral FR Couvercle, neutre ES Cubierta, neutro PT Tampa RU Кожух 		620 268 0157	02.20675 
BM 371.304/334/339	<ul style="list-style-type: none"> EN Gearshift knob DE Schaltknäuf FR Pommeau de levier de vitesses ES Pomo de la palanca de cambios PT Manopla alavanca RU Рукоятка рычага переключения 		000 268 0542	02.20657 
BM 381/383/385/387, 389/391/393/395	<ul style="list-style-type: none"> EN Gear lever valve DE Schalthebelventil FR Soupape levier de vitesses ES Válvula de la palanca de cambios PT Válvula seletora RU Клапан 	repl. Wabco: 463 031 102 0 	385 260 0057	02.20484 

THE ORIGINAL NUMBERS OF THE VEHICLE MANUFACTURER MAY BE USED FOR COMPARISON PURPOSES ONLY AND MUST NOT BE MENTIONED ON INVOICES TO VEHICLE OWNERS.

Gear Shift Lever

Schalthebel • Levier de Vitesses • Palanca del cambio
 Manopla alavanca ex. mudança • Рычаг переключения

Application	Description	Details	Ref.	Erqo No.
BM 617/620/621/622, 623/624/625, 652/655/656/658, 659	<ul style="list-style-type: none"> EN Gear lever valve DE Schalthebelventil FR Soupape levier de vitesses ES Válvula de la palanca de cambios PT Válvula seletora RU Клапан 		001 260 6357	02.20479 



3

BM 371 GV91	<ul style="list-style-type: none"> EN Gear lever valve DE Schalthebelventil FR Soupape levier de vitesses ES Válvula de la palanca de cambios PT Válvula seletora RU Клапан 		001 260 1957	02.20472 
----------------	---	--	--------------	---



BM 381/383/385/387/389 393/395, BM 616/617/619/620/ 621/622/623/624	<ul style="list-style-type: none"> EN Boot DE Manschette FR Manchon ES Retén PT Guarda-pó alavanca câmbio RU Манжета 		389 268 0097	02.20702 
--	--	--	--------------	---



BM 620/621/622/623/ 624/625, BM 645/646/648/649	<ul style="list-style-type: none"> EN Boot DE Manschette FR Manchon ES Guardapolvos PT Guarda-pó alavanca câmbio RU Манжета 		620 268 0097	02.20703 
---	---	--	--------------	---



THE ORIGINAL NUMBERS OF THE VEHICLE MANUFACTURER MAY BE USED FOR COMPARISON PURPOSES ONLY AND MUST NOT BE MENTIONED ON INVOICES TO VEHICLE OWNERS.

Gear Shift Lever









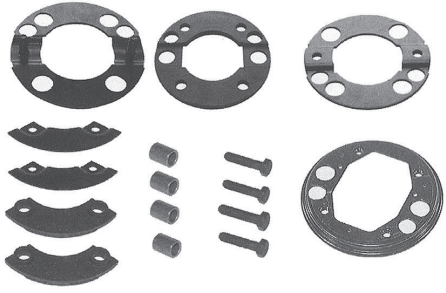

Schalthebel • Levier de Vitesses • Palanca del cambio
 Manopla alavanca ex. mudança • Рычаг переключения

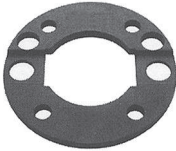
Application	Description	Details	Ref.	Erqo No.
BM 620/621/622/623, 624	EN Boot DE Manschette FR Manchon ES Guardapolvos PT Guarda-pó alavanca câmbio RU Манжета		620 268 0197	02.20704 
BM 625, 652/653/654/ 655/656/658/659 (K043330--)	EN Boot DE Manschette FR Manchon ES Guardapolvos PT Guarda-pó alavanca câmbio RU Манжета		655 268 0097	02.20706 
BM 625, BM 652/653/654/655/656/ 658/659 (--K043329)	EN Boot DE Manschette FR Manchon ES Guardapolvos PT Guarda-pó alavanca câmbio RU Манжета		652 268 0197	02.20705 
NG/MK/SK -- chassis	EN Repair kit, boot DE Reparatursatz, Manschette FR Kit de réparation, manchon ES Kit de reparación, guardapolvos PT Jogo reparo, guarda-pó alavanca câmbio RU Ремонтный комплект, Манжета		001 981 3931 S	02.23169 
NG/MK/SK -- chassis	EN Pin DE Stift FR Axe ES Pasador PT Pino RU Штифт		385 268 1474	02.20683 

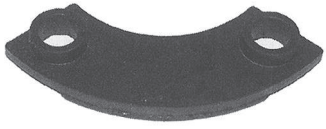
Application	Description	Details	Ref.	Erqo No.
NG/MK/SK -- chassis	<ul style="list-style-type: none"> EN Boot DE Manschette FR Manchon ES Retén PT Luva mancai alavanca mudanças RU Манжета 		620 268 0196	02.20701 
3 NG/MK/SK -- chassis	<ul style="list-style-type: none"> EN Joint bearing DE Gelenklager FR Palier articulé ES Cojinete articulado PT Rolamento articulação RU Подшипник оси двуплечего рычага 		001 981 3931	02.22400 
NG/MK/SK -- chassis	<ul style="list-style-type: none"> EN Lock ring DE Sicherungsring FR Jonc d'arrêt ES Anillo de seguridad PT Anel trava RU Стопорное кольцо 			02.15618 
BM 650/651/652/653, 654/655/656/657, 658/659 chassis K40604--	<ul style="list-style-type: none"> EN Pin DE Bolzen FR Axe ES Bulón PT Pino RU Болт 		655 268 0074	02.20685 
BM 620/621/622/623, 624/625/645/648, 652/653/654/655, 656/658/659	<ul style="list-style-type: none"> EN Needle bearing DE Nadellager FR Roulement à aiguilles ES Cojinete agujas PT Rolamento caixa RU Игольчатый подшипник 		010 981 8010	02.22379 
BM 380/381/383/385, 387/389, 616/617/619 620/621/622/623, 624/625, 646.322/327	<ul style="list-style-type: none"> EN Bracket DE Halter FR Support ES Sujeción PT Suporte RU Кронштейн 		385 260 1962	02.20488 

Gear Shift Lever

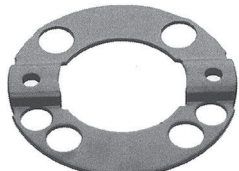
Schalthebel • Levier de Vitesses • Palanca del cambio
Manopla alavanca ex. mudança • Рычаг переключения

Application	Description	Details	Ref.	Erqo No.
MK/SK -- chassis K040603	<ul style="list-style-type: none"> EN Repair kit DE Reparatursatz FR Kit de réparation ES Kit de reparación PT Jogo reparo RU Ремонтный комплект 		385 260 1962 S	02.23170 
NG/MK/SK	<ul style="list-style-type: none"> EN Rubber ring DE Gummiring FR Anneau de caoutchouc ES Anillo de goma PT Anel protetor RU Резиновое кольцо 		385 268 0392	02.20699 
NG/MK/SK	<ul style="list-style-type: none"> EN Rubber pad DE Gummipolster FR Coussin de caoutchouc ES Acolchado de goma PT Coxim RU Резиновая прокладка 		385 268 0492	02.20700 
MK/SK	<ul style="list-style-type: none"> EN Bracket DE Halter FR Support ES Sujeción PT Suporte RU Кронштейн 		385 268 1640	02.20655 
MK/SK -- chassis K040603	<ul style="list-style-type: none"> EN Bracket DE Halter FR Support ES Sujeción PT Suporte RU Кронштейн 		389 268 0440	02.20656 

Application	Description	Details	Ref.	Erqo No.
MK/SK -- chassis K040603	<ul style="list-style-type: none"> EN Bracket DE Halter FR Support ES Sujeción PT Suporte RU Кронштейн 		389 260 5262	02.20489 
				
3 NG/MK/SK	<ul style="list-style-type: none"> EN Screw DE Schraube FR Vis ES Tornillo PT Parafuso RU Болт 	M 8x35	304017 008018	02.22937 
				
MK/SK -- chassis K040603	<ul style="list-style-type: none"> EN Tube DE Rohr FR Tuyau ES Tubo PT Vucha RU Труба 		389 268 0525	02.20645 
				
NG/MK/SK	<ul style="list-style-type: none"> EN Shifting cylinder DE Schaltzylinder FR Vérin de commande ES Cilindro de mando PT Cilindro desengate hidráulico RU Цилиндр управления включением 		385 260 0563	02.20496 
				
NG/MK/SK chassis--	<ul style="list-style-type: none"> EN Pawl, shifting rod DE Sperrklinke, Schaltstange FR Poignée de verrouillage, Tringle boîte de vitesses ES Trinquete de bloqueo, Barra de mando PT Lingüeta Varão, Comando Câmbio RU Стопорная защелка, шток переключения передач 		620 260 0087	02.20504 
				
BM 625/653/655/656, 658/659	<ul style="list-style-type: none"> EN Ball joint DE Kugelgelenk FR Rotule ES Rótula PT Articulação alavanca RU Шариковый шарнир 		000 996 6845	02.22578 
				

Gear Shift Lever

Schalthebel • Levier de Vitesses • Palanca del cambio
Manopla alavanca ex. mudança • Рычаг переключения

Application	Description	Details	Ref.	Erqo No.
BM 625/653/655/656, 659	<ul style="list-style-type: none"> EN Ball joint DE Kugelgelenk FR Rotule ES Rótula PT Articulação alavanca RU Шариковый шарнир 		000 996 6645	02.22576 
BM 625/655/656/658, 659	<ul style="list-style-type: none"> EN Ball joint DE Kugelgelenk FR Rotule ES Rótula PT Articulação alavanca RU Шариковый шарнир 		000 996 6745	02.22577 
BM 625/650/651/652, 653/654/656/658, 659	<ul style="list-style-type: none"> EN Ball joint, right hand thread DE Kugelgelenk, Rechtsgewinde FR Rotule direction filetage à droite ES Rótula, Rosca derecha PT Articulação alavanca, rosca direita RU Шариковый шарнир, Правая резьба 		000 996 5545	02.22574 
BM 625/650/651/652, 653/654/655/656, 659	<ul style="list-style-type: none"> EN Ball joint, left hand thread DE Kugelgelenk, Linksgewinde FR Rotule direction filetage à gauche ES Rótula, Rosca izquierda PT Articulação alavanca, rosca esquerda RU Шариковый шарнир, Левая резьба 		000 996 5645	02.22575 
BM 620/621/622/623, 624/625, 650/652/653/654, 655/656/659	<ul style="list-style-type: none"> EN Ball joint DE Kugelgelenk FR Rotule ES Rótula PT Articulação alavanca RU Шариковый шарнир 		000 268 5989	02.20693 
MK/SK	<ul style="list-style-type: none"> EN Connector DE Verbindungsstück FR Raccord ES Pieza de unión PT Conector RU Соединительный элемент 		620 268 0028	02.20647 

THE ORIGINAL NUMBERS OF THE VEHICLE MANUFACTURER MAY BE USED FOR COMPARISON PURPOSES ONLY AND MUST NOT BE MENTIONED ON INVOICES TO VEHICLE OWNERS.

Application	Description	Details	Ref.	Erqo No.
-------------	-------------	---------	------	----------

5 S 110 GP,
 5 S 111 GP

- EN Gasket kit, gearbox
- DE Dichtsatz, Getriebe
- FR Kit de joints, boîte de vitesses
- ES Juego de juntas, Caja de cambios
- PT Jogo junta, caixa marcha
- RU Комплект уплотнителей

1269 298 975

02.23171

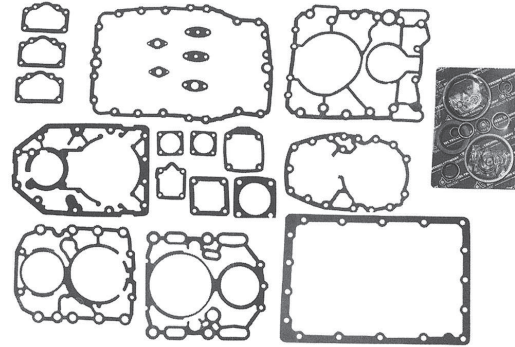

3

16 S 130

- EN Gasket kit, gearbox
- DE Dichtsatz, Getriebe
- FR Kit de joints, boîte de vitesses
- ES Juego de juntas, Caja de cambios
- PT Jogo junta, caixa marcha
- RU Комплект уплотнителей

02.23350

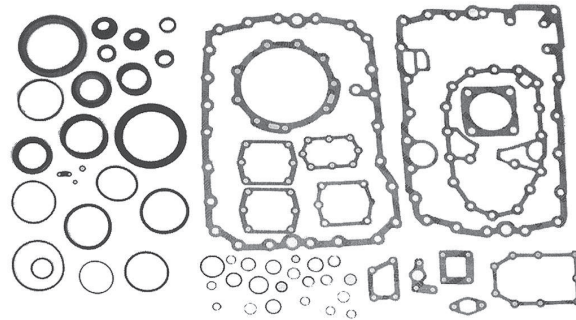

5 S 110 GP,
 5 S 111 GP

- EN Gasket kit, gearbox
- DE Dichtsatz, Getriebe
- FR Kit de joints, boîte de vitesses
- ES Juego de juntas, Caja de cambios
- PT Jogo junta, caixa marcha
- RU Комплект уплотнителей

1269 298 933

02.23172

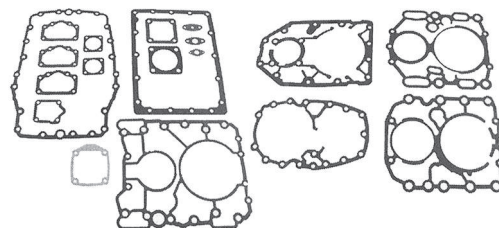





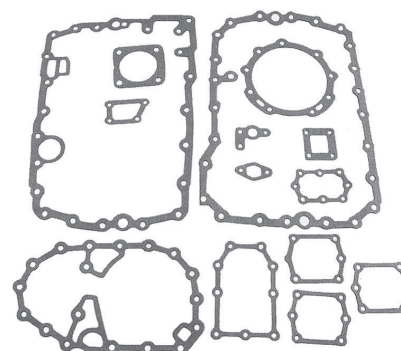

16 A 130,
 16S 160

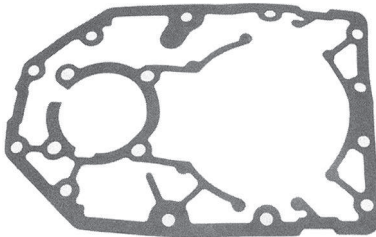





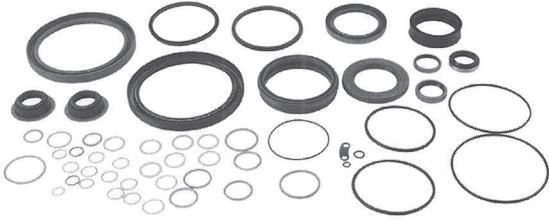

- EN Gasket kit
- DE Dichtsatz
- FR Kit de joints
- ES Kit de juntas
- PT Jogo junta
- RU Комплект уплотнителей

02.23351











Application	Description	Details	Ref.	Erqo No.
5 S 110/111	<ul style="list-style-type: none"> EN Gasket DE Dichtung FR Joint ES Junta PT Junta RU Уплотнение 		001 264 5680	02.20593 
GV 4/95, G/GV4/110	<ul style="list-style-type: none"> EN Gasket DE Dichtung FR Joint ES Junta PT Junta RU Уплотнение 		387 261 4380	02.20515 
5 S 110/111	<ul style="list-style-type: none"> EN Gasket DE Dichtung FR Joint ES Junta PT Junta RU Уплотнение 		000 264 7680	02.20591 
G 125/135/155/180, G 200/210/240	<ul style="list-style-type: none"> EN Gasket DE Dichtung FR Joint ES Junta PT Junta RU Уплотнение 		945 261 0080	02.20517 
5 S 110 GP, 5 S 111 GP	<ul style="list-style-type: none"> EN Seal ring kit, gearbox DE Dichtringsatz, Getriebe FR Kit de joints, boîte de vitesses ES Juego de anillos, Caja de cambios PT Jogo anel vedação, caixa marcha RU Комплект уплотнительных колец 		1269 298 928	02.23173 

THE ORIGINAL NUMBERS OF THE VEHICLE MANUFACTURER MAY BE USED FOR COMPARISON PURPOSES ONLY AND MUST NOT BE MENTIONED ON INVOICES TO VEHICLE OWNERS.



Application	Description	Details	Ref.	Erqo No.
16 S 130	<ul style="list-style-type: none"> EN Seal ring kit DE Dichtringsatz FR Jeu de bagues d'étanchéité ES Juego de retenes PT Jogo anel vedação RU Комплект уплотнительных колец 		1295 298 917	02.19425 
				
GM 713/714	<ul style="list-style-type: none"> EN Seal ring DE Wellendichtring FR Bague d'étanchéité ES Anillo retén PT Retentor RU Уплотнительное кольцо 	46 x 64 x 8	015 997 0347	02.22681 
				
GM 712/718/719	<ul style="list-style-type: none"> EN Seal ring DE Dichtring FR Bague d'étanchéité ES Anillo obturador PT Retentor RU Уплотнительное кольцо 	48 x 69 x 10	007 997 2047	02.22661 
				
GM 717/718/719	<ul style="list-style-type: none"> EN Oil seal DE Wellendichtring FR Joint speed ES Anillo retén PT Retentor RU Сальник 	85 x 105 x 10	008 997 3347	02.22664 
				
GM 717/718/719	<ul style="list-style-type: none"> EN Oil seal DE Wellendichtring FR Joint speed ES Anillo retén PT Retentor RU Сальник 	85 x 105 x 10	011 997 8547	02.22668 
				

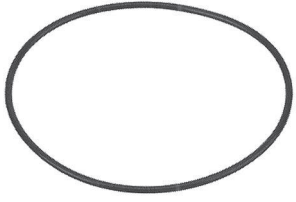

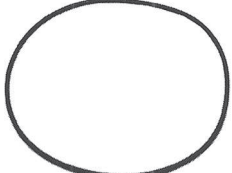





Application	Description	Details	Ref.	Erqo No.
GM 717/718/719	<ul style="list-style-type: none"> EN Oil seal DE Wellendichtring FR Joint speed ES Anillo retén PT Retentor RU Уплотнительное кольцо 	48 x 75 x 8	008 997 3847	02.22665 
				
GM 710/717/718/719	<ul style="list-style-type: none"> EN Oil seal DE Wellendichtring FR Joint speed ES Anillo retén PT Retentor RU Сальник 	55 x 75 x 8	007 997 2247	02.22662 
				
GM 714/715	<ul style="list-style-type: none"> EN Oil seal DE Wellendichtring FR Joint speed ES Retén PT Retentor RU Сальник 	52 x 68 x 8	015 997 1647	02.22682 
				
GM 714/715	<ul style="list-style-type: none"> EN Oil seal DE Wellendichtring FR Joint speed ES Anillo retén PT Retentor RU Сальник 	95 x 115 x 13 / 12	013 997 7347	02.22676 
				
GM 714/715	<ul style="list-style-type: none"> EN Oil seal DE Wellendichtring FR Joint speed ES Anillo retén PT Retentor RU Сальник 	95 x 115 x 13 / 12	013 997 7247	02.22675 
				





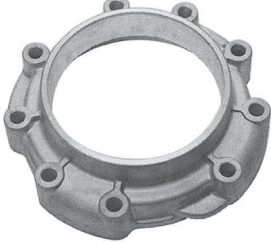

THE ORIGINAL NUMBERS OF THE VEHICLE MANUFACTURER MAY BE USED FOR COMPARISON PURPOSES ONLY AND MUST NOT BE MENTIONED ON INVOICES TO VEHICLE OWNERS.

Application	Description	Details	Ref.	Erqo No.
GM 714/715	(EN) Oil seal (DE) Wellendichtring (FR) Joint speed (ES) Retén (PT) Anel óleo (RU) Сальник	80 x 104 x 10	018 997 7147	02.22692 
				
BM 713/714/715 GV 4/95, G/GV4/110, G 125/135/155/180, G 200/210/240	(EN) Seal ring (DE) Dichtring (FR) Bague d'étanchéité (ES) Retén (PT) Anel vedação (RU) Уплотнительное кольцо	38 x 52 x 7 ACM	005 997 3647	02.22657 
				
BM 713/714/715 GV 4/95, G/GV4/110, G 125/135/155/180, G 200/210/240	(EN) Seal ring (DE) Dichtring (FR) Bague d'étanchéité (ES) Retén (PT) Anel vedação (RU) Уплотнительное кольцо	30 x 40 x 7 ACM	005 997 3547	02.22656 
				
BM 714/715 GV 4/95, G/GV4/110	(EN) Seal ring (DE) O-Ring (FR) Bague d'étanchéité (ES) Retén (PT) Anel vedação (RU) Уплотнительное кольцо		028 997 2348	02.22737 
				
BM 714/715 G 125/135/155/180, G 200/210/240	(EN) O-ring (DE) O-Ring (FR) Joint torique (ES) Junta tórica (PT) Anel (RU) Уплотнительное кольцо	147,0 x 3,0 mm	015 997 2848	02.22719 
				





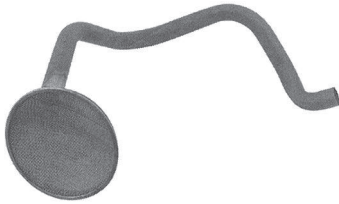

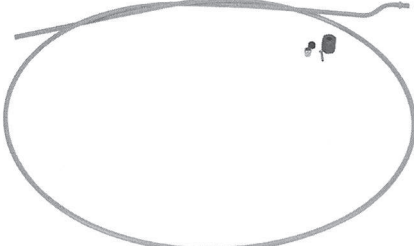
THE ORIGINAL NUMBERS OF THE VEHICLE MANUFACTURER MAY BE USED FOR COMPARISON PURPOSES ONLY AND MUST NOT BE MENTIONED ON INVOICES TO VEHICLE OWNERS.



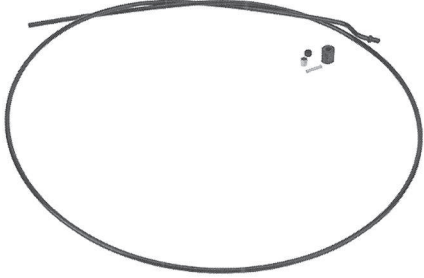

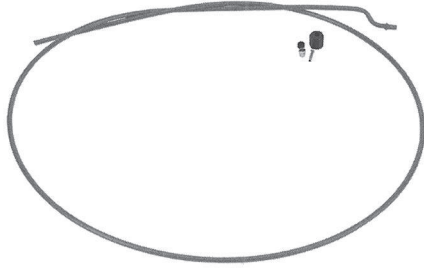

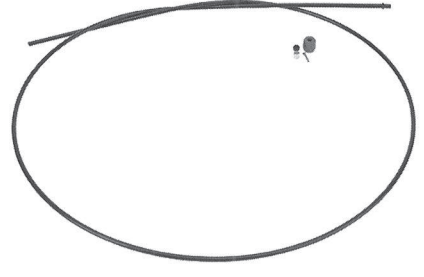

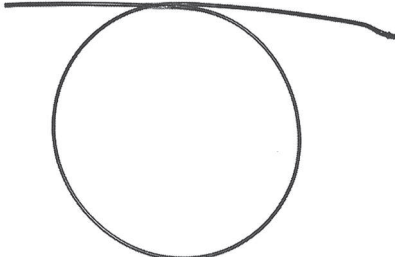
Application	Description	Details	Ref.	Erqo No.
BM 715 G 200/210/240	EN O-ring DE O-Ring FR Joint torique ES Junta tórica PT Anel RU Уплотнительное кольцо	139,5 x 3,0 mm	028 997 2248	02.22736 
BM 714/715 G125/135/155/180, G 200/210/240	EN O-ring DE O-Ring FR Anneau torique ES Junta tórica PT Anel-o RU Уплотнительное кольцо		015 997 2748	02.22718 

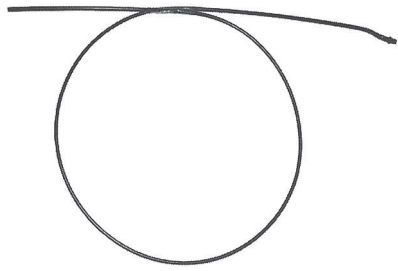
Application	Description	Details	Ref.	Erqo No.
OM 401 LA Euro I, OM 402 LA Euro I, O M 441 + LA, OM 442 + LA (motor 789374--) V 730, 731, 733 H 740, 741, 742, 744, 745, 746, 748 GM 710/717	<ul style="list-style-type: none"> EN Drain plug DE Verschlusschraube FR Bouchon de vidange ES Tapón roscado PT Vujão RU Резьбовая пробка 	M 24 x 1,5	352 997 0032	02.22598 
				
GM 710/712/717/718/719	<ul style="list-style-type: none"> EN Drain plug DE Verschlusschraube FR Bouchon de vidange ES Tapón roscado PT Vujão RU Резьбовая пробка 	M 24 x 1,5	000 997 9930	02.22589 
				
BM 710/712/717/718/719	<ul style="list-style-type: none"> EN Drain plug DE Verschlusschraube FR Bouchon de vidange ES Tapón roscado PT Vujão RU Резьбовая пробка 	M 24 x 1,5	000 997 9730	02.22588 
				
BM 710/717, 16 S 112, 16S 130, 16 S 160, 16 S 190	<ul style="list-style-type: none"> EN Aluminium cover DE Aluminiumdeckel FR Couvercle aluminium ES Tapa de aluminio PT Tampa alumínio RU Алюминиевая крышка 		000 261 0932	02.20507 
				
GM 717/719 5 K 110 /111 GP,5 S110/111 GP, 5 S 110/111 G PA, GV 90/1	<ul style="list-style-type: none"> EN Spray pipe DE Spritzrohr FR Tube d'injection ES Tubo de inyección PT Tubo spray RU Жиклер 	repl. ZF: 1269 301 083	000 260 1485	02.20500 
				

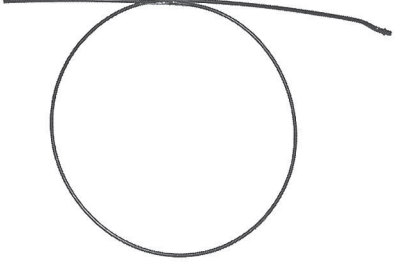
Application	Description	Details	Ref.	Erqo No.
GM 714 G 155/180 (gearbox 056044--)	<ul style="list-style-type: none"> EN Oil spray tube DE Ölleitung FR Tube ES Tubo PT Tubo óleo RU Труба 		389 260 1485	02.20502 
				
GM 714/715 G125/135/155/180, (gearbox 297457--), G 200	<ul style="list-style-type: none"> EN Oil spray tube DE Ölleitung FR Tube ES Tubo PT Tubo óleo RU Труба 		655 260 0985	02.20503 
				
GM 717/719 5 K 110 /111 GR5 S110/111 G R 5 S 110/111 G PA, GV 90/1	<ul style="list-style-type: none"> EN Oil suction pipe DE Ölsaugrohr FR Tuyau d'aspiration d'huile ES Tubo de succión PT Tubo sucção óleo RU Маслозаборная трубка 	repl. ZF: 0501 203 034	000 260 3785	02.20501 
				
N G/M K/S K	<ul style="list-style-type: none"> EN Molded nylon hose, kit yellow DE Poly-Leitung, Satz gelb FR Tube nylon, kit jaune ES Tubería de poliéster, kit amarillo PT Tubo nylon, jogo amarelo RU Полимерный трубопровод желтая 	L = 108 mm	301 997 1282	02.22761 
				

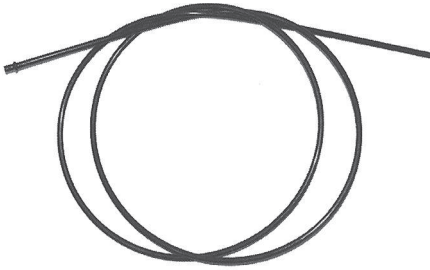



THE ORIGINAL NUMBERS OF THE VEHICLE MANUFACTURER MAY BE USED FOR COMPARISON PURPOSES ONLY AND MUST NOT BE MENTIONED ON INVOICES TO VEHICLE OWNERS.







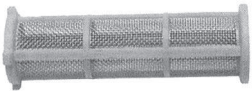

Application	Description	Details	Ref.	Erqo No.
NG/MK/SK	<ul style="list-style-type: none"> EN Molded nylon hose, kit black DE Poly-Leitung, Satz schwarz FR Tube nylon, kit noir ES Tubería de poliéster, kit negro PT Tubo nylon, jogo preto RU Полимерный трубопровод черные 	L = 108 mm		02.22763 
				
NG/MK/SK	<ul style="list-style-type: none"> EN Molded nylon hose, kit red DE Poly-Leitung, Satz rot FR Tube nylon, kit rouge ES Tubería de poliéster, kit rojo PT Tubo nylon, jogo vermelho RU Полимерный трубопровод красного цвета 	L = 108 mm	301 997 1482	02.22763 
				
NG/MK/SK	<ul style="list-style-type: none"> EN Molded nylon hose, kit black DE Poly-Leitung, Satz schwarz FR Tube nylon, kit noir ES Tubería de poliéster, kit negro PT Tubo nylon, jogo preto RU Полимерный трубопровод черные 	L = 130 mm	301 997 1382	02.22762 
				
NG/MK/SK	<ul style="list-style-type: none"> EN Molded nylon hose, red DE Poly-Leitung, rot FR Tube nylon, rouge ES Tubería de poliéster, roja PT Tubo nylon, vermelho RU Полимерный трубопровод, красного цвета 	L = 108 mm		02.22763 
				

Application	Description	Details	Ref.	Erqo No.
NG/MK/SK	<ul style="list-style-type: none"> EN Molded nylon hose, yellow DE Poly-Leitung, gelb FR Tube nylon, jaune ES Tubería de poliéster, amarillo PT Tubo nylon, amarelo RU Полимерный трубопровод, желтая 	L = 108 mm	014 997 2982	02.22759 
				
NG/MK/SK	<ul style="list-style-type: none"> EN Molded nylon hose, black DE Poly-Leitung, schwarz FR Tube nylon, noir ES Tubería de poliéster múltiple, negro PT Tubo nylon, preto RU Полимерный трубопровод, черные 	L = 108 mm		02.22763 
				
NG/MK/SK	<ul style="list-style-type: none"> EN Molded nylon hose, black DE Poly-Leitung, schwarz FR Tube nylon, noir ES Tubería de poliéster, negro PT Tubo nylon preto, preto RU Полимерный трубопровод, черные 	L = 130 mm		02.22762 
				
AK 6-90, 5 K 90/91, 5 K 110	<ul style="list-style-type: none"> EN Inner disc DE Innenlamelle FR Lamelle interne ES Lámina interior PT Disco interno RU Внутренний фрикционный диск 		000 255 0401	02.20459 
				
AK 6-90, 5 K 90/91, 5K110	<ul style="list-style-type: none"> EN Diaphragm DE Membrane FR Membrane ES Membrana PT Diafragma RU Мембрана 		343 264 0547	02.20582 
				









Gearbox Housing

Getriebegehäuse • Carter, Boîte de vitesses • Cáster Caja de Cambios
 Carcaça Caixa de Mudança • Картер коробки передач

Application	Description	Details	Ref.	Erqo No.
BM 714/715 G 135/155/180... G 200/210/240...	<ul style="list-style-type: none"> EN Valve DE Ventil FR Soupape ES Válvula PT Jogo reparo válvula RU Клапан 		655 260 0157	02.20485 
BM 714/715 G 135/155/180... G 200/210/240...	<ul style="list-style-type: none"> EN Oil pump, gearbox DE Ölpumpe, Getriebe FR Pompe à huile, boîte de vitesses ES Bomba de aceite, caja de cambios PT Bomba óleo, caixa marcha RU Масляный насос 		389 260 0690	02.20506 
BM 714/715 G 135/155/180... G 200/210/240...	<ul style="list-style-type: none"> EN Strainer DE Sieb FR Tamis ES Tamiz de aceite PT Filtro óleo câmbio RU Сетчатый фильтр 		389 269 0321	02.20707 

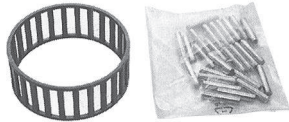
Application	Description	Details	Ref.	Erqo No.
BM 710/717/719	<ul style="list-style-type: none"> EN Bearing kit DE Lagersatz FR Kit de roulement à billes ES Juego rodamientos PT Jogo de rolamento RU Комплект подшипника 	repl. ZF 1292 298 905		02.23174
				
S 6-80, 5 S-90, 5 K-91, 15 K-110/111, 16 S-112/130/160/190	<ul style="list-style-type: none"> EN Needle cage DE Nadelkäfig FR Roulement à aiguilles ES Portaagujas PT Rolamento agulha RU Сепаратор игольч. подшипника 	45 x 53 x 21	010 981 1010	02.22377
				
AK 6-80, S 6-80	<ul style="list-style-type: none"> EN Needle cage DE Nadelkäfig FR Roulement à aiguilles ES Portaagujas PT Rolamento agulha RU Сепаратор игольч. подшипника 	57 x 63 x 43	005 981 0510	02.22362
				
AK 6-80, S 6-80	<ul style="list-style-type: none"> EN Needle cage DE Nadelkäfig FR Roulement à aiguilles ES Portaagujas PT Rolamento agulha RU Сепаратор игольч. подшипника 	58 x 65 x 36	013 981 9110	02.22387
				
AK 6-80, S 6-80	<ul style="list-style-type: none"> EN Needle cage DE Nadelkäfig FR Roulement à aiguilles ES Portaagujas PT Rolamento agulha RU Сепаратор игольч. подшипника 	80 x 88 x 40	012 981 5910	02.22383
				

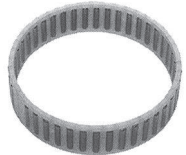





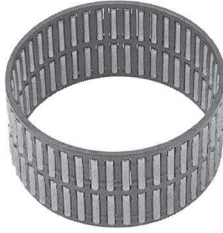

THE ORIGINAL NUMBERS OF THE VEHICLE MANUFACTURER MAY BE USED FOR COMPARISON PURPOSES ONLY AND MUST NOT BE MENTIONED ON INVOICES TO VEHICLE OWNERS.

Application	Description	Details	Ref.	Erqo No.
AK 6-80, S 6-80	<ul style="list-style-type: none"> EN Needle cage DE Nadelkäfig FR Roulement à aiguilles ES Portaagujas PT Rolamento agulha RU Сепаратор игольч. подшипника 	95 x 103 x 40	013 981 9210	02.22388 
				
AK 6-80, S 6-80, 4S-150	<ul style="list-style-type: none"> EN Needle cage DE Nadelkäfig FR Roulement à aiguilles ES Portaagujas PT Rolamento agulha RU Сепаратор игольч. подшипника 	80 x 88 x 46	002 981 1710	02.22360 
				
AK 6-80, S 6-80	<ul style="list-style-type: none"> EN Needle cage DE Nadelkäfig FR Roulement à aiguilles ES Portaagujas PT Rolamento agulha RU Сепаратор игольч. подшипника 	84 x 96 x 36	001 981 7410	02.22358 
				
16 S-112	<ul style="list-style-type: none"> EN Needle cage DE Nadelkäfig FR Roulement à aiguilles ES Portaagujas PT Rolamento agulha RU Сепаратор игольч. подшипника 		012 981 0610	02.22382 
				
G 155/180/200, G 4/65, G 4/95, GV 4/95	<ul style="list-style-type: none"> EN Needle cage DE Nadelkäfig FR Roulement à aiguilles ES Portaagujas PT Rolamento agulha RU Сепаратор игольч. подшипника 	85 x 93 x 37	009 981 1610	02.22375 
				

THE ORIGINAL NUMBERS OF THE VEHICLE MANUFACTURER MAY BE USED FOR COMPARISON PURPOSES ONLY AND MUST NOT BE MENTIONED ON INVOICES TO VEHICLE OWNERS.

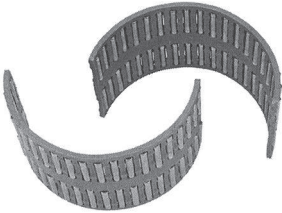





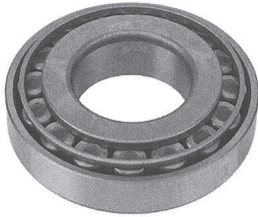

Application	Description	Details	Ref.	Erqo No.
G 155/180, G 200/210/240	EN Needle cage DE Nadellager FR Roulement à aiguilles ES Portaagujas PT Rolamento agulha RU Игольчатый подшипник	42 x 50 x 51	012 981 8910	02.22384 
				
G 155/180, G 200/210/240, G 4/110, GV 4/110	EN Needle cage DE Nadelkäfig FR Roulement à aiguilles ES Portaagujas PT Rolamento agulha RU Сепаратор игольч. подшипника	75 x 83 x 55	019 981 4410	02.22393 
				
G 210/240	EN Needle cage DE Nadelkäfig FR Roulement à aiguilles ES Portaagujas PT Rolamento agulha RU Сепаратор игольч. подшипника	89 x 97 x 40	016 981 0010	02.22389 
				
G 155/180, G 200/210/240, G 4/95 GV 4/95	EN Needle cage DE Nadelkäfig FR Roulement à aiguilles ES Portaagujas PT Rolamento agulha RU Сепаратор игольч. подшипника	78 x 86 x 35	009 981 1510	02.22374 
				
G 125/135/155/180, G 200/210/240	EN Needle cage DE Nadelkäfig FR Roulement à aiguilles ES Portaagujas PT Rolamento agulha RU Сепаратор игольч. подшипника	85 x 93 x 53	018 981 6610	02.22391 
				

THE ORIGINAL NUMBERS OF THE VEHICLE MANUFACTURER MAY BE USED FOR COMPARISON PURPOSES ONLY AND MUST NOT BE MENTIONED ON INVOICES TO VEHICLE OWNERS.

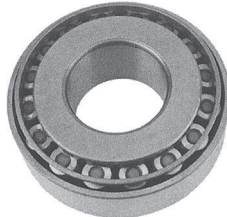

Application	Description	Details	Ref.	Erqo No.
G 4/110, GV 4/110	<ul style="list-style-type: none"> EN Needle cage DE Nadelkäfig FR Cage de palier à aiguilles ES Cojinete de agujas PT Rolamento agulha RU Сепаратор игольч. подшипника 	92 x 100 x 49,5 mm	008 981 8610	02.22370 
				
5 S-111, S 6-90	<ul style="list-style-type: none"> EN Needle cage DE Nadelkäfig FR Cage de palier à aiguilles ES Cojinete de agujas PT Rolamento agulha RU Сепаратор игольч. подшипника 		009 981 9010	02.22376 
				
5 K-110, 5 S-110/111, AK/S 6-80, S 6-90	<ul style="list-style-type: none"> EN Needle cage DE Nadellager FR Cage de palier à aiguilles ES Cojinete de agujas PT Rolamento agulha RU Сепаратор игольч. подшипника 		011 981 1210	02.22380 
				
AK 6-80, S 6-80, 5 K-110, 5 S-90/110/111	<ul style="list-style-type: none"> EN Roller bearing DE Rollenlager FR Palier à rouleaux ES Rodamiento de rodillos PT Rolamento RU Роликоподшипник 		004 981 5801	02.22320 
				
16S 112, 16S 130	<ul style="list-style-type: none"> EN Cylinder roller bearing DE Zylinderrollenlager FR Roulement à cylindre palier ES Rodamiento de rodillos cilíndricos PT Rolamento RU Подшипник 		001 981 9912	02.22394 
				







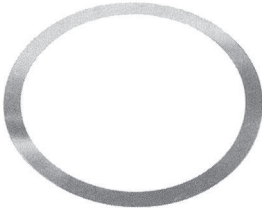

Application	Description	Details	Ref.	Erqo No.
16 S-112/130, 16 S-160/190	<ul style="list-style-type: none"> EN Cylinder roller bearing DE Zylinderrollenlager FR Roulement à cylindre palier ES Rodamiento de rodillos cilíndricos PT Rolamento RU Подшипник. 	86 x 102 x 18	005 981 3801	02.22323 
4 S-150, 5 K-110, 5 S-110/111, 16 S-112/130, 16 S-160/190	<ul style="list-style-type: none"> EN Tapered roller bearing DE Kegelrollenlager FR Roulement à rouleaux coniques ES Rodamiento rodillos cónicos PT Rolamento RU Роликоподшипник 	50,8 x 100 x 35	001 980 8102	02.22318 
16 S-160/190	<ul style="list-style-type: none"> EN Cylinder roller bearing DE Zylinderrollenlager FR Roulement à cylindre palier ES Rodamiento de rodillos cilíndricos PT Rolamento RU Подшипник. 		008 981 6901	02.22328 
16 S 112	<ul style="list-style-type: none"> EN Cylinder roller bearing DE Zylinderrollenlager FR Roulement ES Rodamiento de rodillos cilíndricos PT Retentor RU Подшипник с роликами 	repl. FAG 541640	004 981 7601	02.22321 
16 S-160/190	<ul style="list-style-type: none"> EN Cylinder roller bearing DE Zylinderrollenlager FR Roulement ES Rodamiento de rodillos cilíndricos PT Rolamento RU Подшипник с роликами 		004 981 8001	02.22322 

Application	Description	Details	Ref.	Erqo No.
S 6-90	<ul style="list-style-type: none"> EN Tapered roller bearing DE Kegelrollenlager FR Roulement à rouleaux coniques ES Rodamiento de rodillos cónicos PT Rolamento RU Роликоподшипник 	repl. FAG 32309	004 981 1305	02.23175 
				
AK 6-80, S 6-80, 4S-150	<ul style="list-style-type: none"> EN Cylinder roller bearing DE Zylinderrollenlager FR Roulement à cylindre palier ES Rodamiento de rodillos cilíndricos PT Rolamento RU Подшипник 	70 x 150 x 35	005 981 8501	02.22324 
				
16 S-112	<ul style="list-style-type: none"> EN Tapered roller bearing DE Kegelrollenlager FR Roulement à rouleaux coniques ES Rodamiento de rodillos cónicos PT Rolamento RU Роликоподшипник 	50,8 x 104,7 x 39,6	001 980 8002	02.22317 
				
G 125/135/155/180, G 200/210/240	<ul style="list-style-type: none"> EN Ball bearing DE Kugellager FR Roulement à billes ES Rodamiento de bolas PT Rolamento RU Шариковый подшипник 	repl. Koyo 16017/1YDC3+27B	008 981 1325	02.22399 
				
G 125/135/155/180, G 200/210/240	<ul style="list-style-type: none"> EN Ball bearing DE Kugellager FR Roulement à billes ES Rodamiento de bolas PT Rolamento RU Шариковый подшипник 	repl. FAG 6217 C3	004 981 9325	02.22396 
				

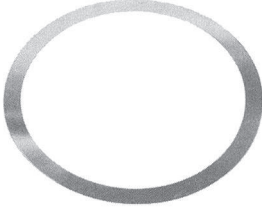

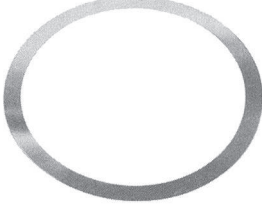





Application	Description	Details	Ref.	Erqo No.
G 155/180, G 200/210/240	<ul style="list-style-type: none"> EN Tapered roller bearing DE Kegellochenlager FR Roulement à rouleaux coniques ES Rodamiento de rodillos cónicos PT Rolamento RU Роликоподшипник 	repl. FAG 30312	016 981 1205	02.23176 
				
G 155/180/200	<ul style="list-style-type: none"> EN Tapered roller bearing DE Kegellochenlager FR Roulement à rouleaux coniques ES Rodamiento de rodillos cónicos PT Rolamento RU Роликоподшипник 	repl. Timken HM 204010/204043	008 981 2805	02.22345 
				
G 155/180, G 200/210/240	<ul style="list-style-type: none"> EN Tapered roller bearing DE Kegellochenlager FR Roulement à rouleaux coniques ES Rodamiento de rodillos cónicos PT Rolamento RU Роликоподшипник 	repl. FAG 580616	011 981 1305	02.22347 
				
G 210/240	<ul style="list-style-type: none"> EN Tapered roller bearing DE Kegellochenlager FR Roulement à rouleaux coniques ES Rodamiento de rodillos cónicos PT Rolamento RU Роликоподшипник 	repl. NTN ETA-4367V8	015 981 1605	02.22354 
				
G 125/135/155/180, G 200/210	<ul style="list-style-type: none"> EN Roller bearing DE Rollenlager FR Palier à rouleaux ES Rodamiento de rodillos PT Rolamento RU Роликоподшипник 	repl. NTN 32011XVA ETA	014 981 1605	02.22352 
				

THE ORIGINAL NUMBERS OF THE VEHICLE MANUFACTURER MAY BE USED FOR COMPARISON PURPOSES ONLY AND MUST NOT BE MENTIONED ON INVOICES TO VEHICLE OWNERS.

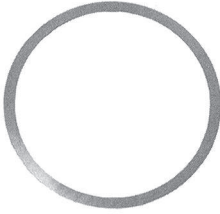

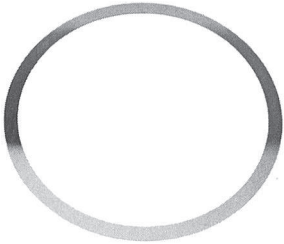







Application	Description	Details	Ref.	Erqo No.
G 155/180, G 200/210/240	(EN) Tapered roller bearing (DE) Kegelrollenlager (FR) Roulement à rouleaux coniques (ES) Rodamiento de rodillos cónicos (PT) Rolamento (RU) Роликоподшипник	50,8 x 100 x 35	015 981 9005	02.22357 
G 210	(EN) Tapered roller bearing (DE) Kegelrollenlager (FR) Roulement à rouleaux coniques (ES) Rodamiento de rodillos cónicos (PT) Rolamento (RU) Роликоподшипник		015 981 7605	02.22356 
G 155/180, G 200/210/240	(EN) Tapered roller bearing (DE) Kegelrollenlager (FR) Roulement à rouleaux coniques (ES) Rodamiento de rodillos cónicos (PT) Rolamento eixo (RU) Роликоподшипник		014 981 6105	02.22353 

Application	Description	Details	Ref.	Erqo No.
BM 710/717/719 S 6-90, 5 S 110 GP, 5 S 111 GP, 16 S 160	<ul style="list-style-type: none"> EN Spacer washer, 0,50 mm DE Abstandscheibe, 0,50 mm FR Entretoise, 0,50 mm ES Arandela distanciadora, 0,50 mm PT Anel espaçador, 0,50 mm RU Дистанционная шайба, 0,50 mm 	repl. ZF 1205 308 038	343 261 2652	02.23177 
				
BM 710/717/719 S 6-90, 5 S 110 GP, 5 S 111 GP, 16 S 160	<ul style="list-style-type: none"> EN Spacer washer, 0,30 mm DE Abstandscheibe, 0,30 mm FR Entretoise, 0,30 mm ES Arandela distanciadora, 0,30 mm PT Anel espaçador, 0,30 mm RU Дистанционная шайба, 0,30 mm 	repl. ZF 1205 308 020	343 261 0752	02.20514 
				
BM 710/717/719 S 6-90, 5 S 110 GP, 5 S 111 GP, 16 S 160	<ul style="list-style-type: none"> EN Spacer washer, 0,20 mm DE Abstandscheibe, 0,20 mm FR Entretoise, 0,20 mm ES Arandela distanciadora, 0,20 mm PT Anel espaçador, 0,20 mm RU Дистанционная шайба, 0,20 mm 	repl. ZF 1205 308 016	343 261 0652	02.20513 
				
BM 718/719 5 S-90, 5 K-91, S 6-90	<ul style="list-style-type: none"> EN Washer, 5,8 mm DE Scheibe, 5,8 mm FR Rondelle, 5,8 mm ES Arandela, 5,8 mm PT Anel, 5,8 mm RU Шайба, 5,8 мм 		000 262 1651	02.20555 
				
BM 718/719 5 S-90, 5 K-91, S 6-90	<ul style="list-style-type: none"> EN Washer, 5,2 mm DE Scheibe, 5,2 mm FR Rondelle, 5,2 mm ES Arandela, 5,2 mm PT Anel, 5,2 mm RU Шайба, 5,2 мм 		000 262 1351	02.20554 
				

THE ORIGINAL NUMBERS OF THE VEHICLE MANUFACTURER MAY BE USED FOR COMPARISON PURPOSES ONLY AND MUST NOT BE MENTIONED ON INVOICES TO VEHICLE OWNERS.

Application	Description	Details	Ref.	Erqo No.
BM 718/719 5 S-90, 5 K-91, S 6-90	<ul style="list-style-type: none"> EN Washer DE Scheibe FR Rondelle ES Arandela PT Anel RU Шайба 		000 262 0951	02.20553 
				
BM 714/715 G 125/135/150/180, G 200	<ul style="list-style-type: none"> EN Spacer washer, 0,40 mm DE Abstandscheibe, 0,40 mm FR Disque d'écartement, 0,40 mm ES Arandela distanciadora, 0,40 mm PT Anel espaçador, 0,40 mm RU Дистанционная шайба, 0,40 мм 		389 262 4452	02.20562 
				
BM 714/715 G 125/135/150/180, G 200	<ul style="list-style-type: none"> EN Spacer washer, 0,50 mm DE Abstandscheibe, 0,50 mm FR Entretoise, 0,50 mm ES Arandela distanciadora, 0,50 mm PT Anel espaçador, 0,50 mm RU Дистанционная шайба, 0,50 мм 		389 262 2054	02.20563 
				
BM 714 G 155/180 - 16 (-- gearbox 129658)	<ul style="list-style-type: none"> EN Bolt DE Bolzen FR Axe ES Bulón PT Parafuso RU Болт 	M 16 x 55	389 990 0119	02.22466 
				
BM 714/715 G 125/135/155/180 (gearbox 129659 --), G 200	<ul style="list-style-type: none"> EN Bolt DE Bolzen FR Axe ES Bulón PT Parafuso RU Болт 	M 16 x 69	389 990 1819	02.22467 
				

THE ORIGINAL NUMBERS OF THE VEHICLE MANUFACTURER MAY BE USED FOR COMPARISON PURPOSES ONLY AND MUST NOT BE MENTIONED ON INVOICES TO VEHICLE OWNERS.





Application	Description	Details	Ref.	Erqo No.
BM 717/719 5 S 110, 5 S 111, 4 S 150	<ul style="list-style-type: none"> EN Spacer ring DE Abstandring FR Entretoise ES Anillo distanciador PT Anel espaçador RU Распорное кольцо 	repl. ZF 0730 061 890	000 264 2951	02.20586 
				
BM 710/717/719 5 S 90/92, 16 S 112, 16 S 130, 16 S 160, 16 S 190	<ul style="list-style-type: none"> EN Lock ring DE Sicherungsring FR Clips de verrouillage ES Anillo de seguridad PT Anel trava RU Стопорное кольцо 		000 262 1073	02.20566 
				
BM 710/717/719 5 S 90/92, 16 S 112, 16 S 130, 16 S 160, 16 S 190	<ul style="list-style-type: none"> EN Spacer ring DE Abstandring FR Entretoise ES Anillo distanciador PT Anel espaçador RU Распорное кольцо 	repl. ZF 0730 061 816	000 262 0673	02.20565 
				
BM 718/719 S 6-90, 5 S 110, 5 S 111	<ul style="list-style-type: none"> EN Spacer ring DE Abstandring FR Entretoise ES Anillo distanciador PT Anel espaçador RU Распорное кольцо 	repl. ZF 0730 361 046	000 264 2751	02.20585 
				
BM 717/719 5 S 110, 5 S 111	<ul style="list-style-type: none"> EN Split ring, 4,1 mm DE Spanning, 4,1 mm FR Bague de serrage, 4,1 mm ES Anillo de fijación, 4,1 mm PT Anel bipartido, 4,1 mm RU Зажимное кольцо, 4,1 мм 		000 264 4029	02.20579 
				

THE ORIGINAL NUMBERS OF THE VEHICLE MANUFACTURER MAY BE USED FOR COMPARISON PURPOSES ONLY AND MUST NOT BE MENTIONED ON INVOICES TO VEHICLE OWNERS.









Application	Description	Details	Ref.	Erqo No.
BM 717/719 5 S 110, 5 S 111	(EN) Split ring - 4,0 mm, complete (DE) Spannring - 4,0 mm, komplett (FR) Bague de serrage - 4,0 mm, complet (ES) Anillo de fijación, 4,0 mm, completo (PT) Anel bipartido - 4,0 mm, completo (RU) Зажимное кольцо - 4,0 мм, в сборе		001 262 0130	02.20532 
5 S-110/111, S 6-80/90	(EN) Split ring, 8,2 mm (DE) Spannring, 8,2 mm (FR) Bague de serrage, 8,2 mm (ES) Anillo de fijación, 8,2 mm (PT) Anel bipartido, 8,2 mm (RU) Зажимное кольцо, 8,2 мм		000 264 3629	02.20578 
AK 6-80, S 6-80, 5 K-110, 5 S-110/111	(EN) Split ring, 7,2 mm (DE) Spannring, 7,2 mm (FR) Bague de serrage, 7,2 mm (ES) Anillo de fijación, 7,2 mm (PT) Anel bipartido, 7,2 mm (RU) Зажимное кольцо, 7,2 мм		000 264 6429	02.20580 
AK 6-80, S 6-80, 5 K-110, 5 S-110/111	(EN) Split ring, 7,0 mm (DE) Spannring, 7,0 mm (FR) Bague de serrage, 7,0 mm (ES) Anillo de fijación, 7,0 mm (PT) Anel bipartido, 7,0 mm (RU) Зажимное кольцо, 7,0 мм		000 264 3129	02.20575 
AK 6-80, S 6-80, 5 K-110, 5 S-110/111	(EN) Split ring, 6,9 mm (DE) Spannring, 6,9 mm (FR) Bague de serrage, 6,9 mm (ES) Anillo de fijación, 6,9 mm (PT) Anel bipartido, 6,9 mm (RU) Зажимное кольцо, 6,9 мм		000 264 3229	02.20576 

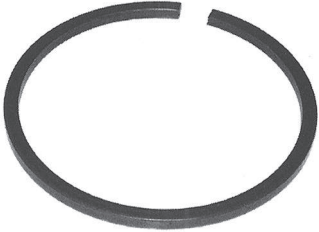

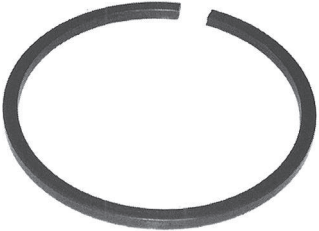

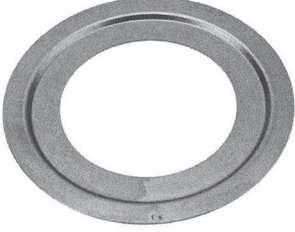





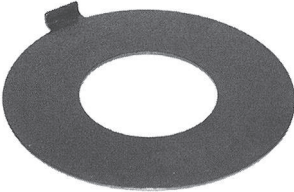

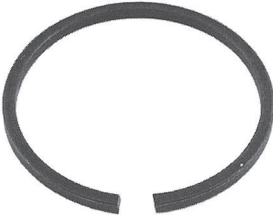
Sample

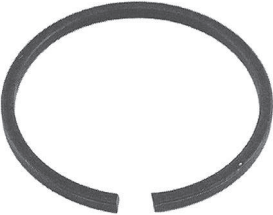
Sample











Application	Description	Details	Ref.	Erqo No.
AK 6-80, S 6-80, 5 K-110, 5 S-110/111	<ul style="list-style-type: none"> EN Split ring, 6,8 mm DE Spannring, 6,8 mm FR Bague de serrage, 6,8 mm ES Anillo de fijación, 6,8 mm PT Anel bipartido, 6,8 mm RU Зажимное кольцо, 6,8 мм 		000 264 3329	02.20577 
				Sample
BM 717/719 5 S 110, 5 S 111	<ul style="list-style-type: none"> EN Spacer washer, 4,8 mm DE Abstandscheibe, 4,8 mm FR Entretoise, 4,8 mm ES Arandela distanciadora, 4,8 mm PT Anel espaçador, 4,8 mm RU Дистанционная шайба, 4,8 мм 		000 262 0052	02.20556 
BM 710/717/718 16S112,16S130, 16 S 160,16 S 190	<ul style="list-style-type: none"> EN Shim, 0,50 mm DE Ausgleichscheibe, 0,50 mm FR Cale, 0,50 mm ES Arandela de ajuste, 0,50 mm PT Calço, 0,50 mm RU Компенсационная шайба, 0,50 мм 	repl.ZF 0730 102 503	000 261 0152	02.20510 
BM 710/717/718 16S112,16 S 130, 16 S 160,16 S 190	<ul style="list-style-type: none"> EN Shim, 0,60 mm DE Ausgleichscheibe, 0,60 mm FR Cale, 0,60 mm ES Arandela de ajuste, 0,60 mm PT Calço, 0,60 mm RU Компенсационная шайба, 0,60 мм 	repl.ZF 0730 102 504	000 261 0252	02.20511 
BM 710/717/718 16 S 112,16 S 130, 16 S 160, 16 S 190	<ul style="list-style-type: none"> EN Shim, 0,80 mm DE Ausgleichscheibe FR Cale, 0,80 mm ES Arandela de ajuste, 0,80 mm PT Calço, 0,80 mm RU Компенсационная шайба, 0,80 мм 		000 261 0252	02.20512 

THE ORIGINAL NUMBERS OF THE VEHICLE MANUFACTURER MAY BE USED FOR COMPARISON PURPOSES ONLY AND MUST NOT BE MENTIONED ON INVOICES TO VEHICLE OWNERS.











Application	Description	Details	Ref.	Erqo No.
BM 717/719 5 S 110, 5 S 111	(EN) Shim, 5,4 mm (DE) Ausgleichscheibe, 5,4 mm (FR) Cale, 5,4 mm (ES) Arandela de ajuste, 5,4 mm (PT) Calço, 5,4 mm (RU) Компенсационная шайба, 5,4 мм		000 262 8752	02.20557 
				
BM 717/719 5 S 110, 5 S 111	(EN) Shim, 5,7 mm (DE) Ausgleichscheibe, 5,7 mm (FR) Cale, 5,7 mm (ES) Arandela de ajuste, 5,7 mm (PT) Calço, 5,7 mm (RU) Компенсационная шайба, 5,7 мм		000 262 8852	02.20558 
				
BM 717/719 6 S-80, 4 S 150, 5 S 110, 5 S 111	(EN) Washer, drive shaft (DE) Scheibe, Antriebswelle (FR) Rondelle, arbre de roue (ES) Arandela, Árbol de transmisión (PT) Arruela, semi eixo (RU) Шайба, Приводной вал	repl. ZF 1269 328 096	000 264 0376	02.20590 
				
BM 710, 717/718/719 AK 6-80, S 6-80, 4 S-150, 5 K-91/110, 5 S-90/110/111, 16 S-112/130/160/190	(EN) Thrust washer (DE) Druckscheibe (FR) Rondelle de calage (ES) Disco de presión (PT) Arruela encosto (RU) Упорная шайба	repl. ZF 0730 150 064	343 263 0062	02.20573 
				
BM 714/715 G 155/180/200	(EN) Thrust washer (DE) Druckscheibe (FR) Rondelle de calage (ES) Arandela de presión (PT) Arruela encosto eixo secundário (RU) Упорная шайба		389 262 0062	02.20564 
				

Application	Description	Details	Ref.	Erqo No.
BM 714/715 G 125/135/155/180, G 200	EN Thrust washer DE Druckscheibe FR Rondelle de calage ES Arandela PT Arruela encosto RU Упорная шайба		389 263 0062	02.20574 
BM 717/719 5 S 110, 5 S 111	EN Spacer washer, 6,30 mm DE Abstandscheibe, 6,30 mm FR Entretoise, 6,30 mm ES Arandela distanciadora, 6,30 mm PT Anel espaçador, 6,30 mm RU Дистанционная шайба, 6,30 мм		000 262 9052	02.20559 
BM 717/719 5S110, 5 S 111	EN Spacer washer, 6,60 mm DE Abstandscheibe, 6,60 mm FR Entretoise, 6,60 mm ES Arandela distanciadora, 6,60 mm PT Anel espaçador, 6,60 mm RU Дистанционная шайба, 6,60 мм		000 262 9152	02.20560 
AK 6-80, S 6-80, 4 S-150, 5 K-110, 5S-90/110/111, 16 S-112/130, 16 S-160/190	EN Repair kit DE Reparatursatz FR Kit de réparation ES Kit de reparación PT Jogo reparo RU Ремонтный комплект	repl. 1295 298 934 		02.23178 
AK 6-80, S 6-80, 4 S-150, 5 K-110, 5 S-90/110/111, 16 S-112/130, 16 S-160/190	EN Repair kit DE Reparatursatz FR Kit de réparation ES Kit de reparación PT Jogo reparo RU Ремонтный комплект			02.23178 
AK 6-80, S 6-80, 4 S-150, 5 K-110, 5 S-90/110/111, 16 S-112/130, 16 S-160/190	EN Plunger DE Druckstück FR Pièce de serrage ES Pieza de presión PT Êmbolo RU Упор	repl. ZF 1240 304 278 	336 264 0239	02.20581 

THE ORIGINAL NUMBERS OF THE VEHICLE MANUFACTURER MAY BE USED FOR COMPARISON PURPOSES ONLY AND MUST NOT BE MENTIONED ON INVOICES TO VEHICLE OWNERS.

Application	Description	Details	Ref.	Erqo No.
AK 6-80, S 6-80, 4S-150, 5 K-110, 5 S-90/110/111, 16 S-112/130, 16 S-160/190	<ul style="list-style-type: none"> EN Spring, inner DE Feder, innen FR Ressort, interne ES Muelle, interior PT Mola, interna para RU Пружина, внутр 	repl. ZF 0732 040 386	336 264 0793	02.20596 
				
AK 6-80, S 6-80, 4 S-150, 5 K-110, 5 S-90/110/111, 16 S-112/130, 16 S-160/190	<ul style="list-style-type: none"> EN Spring, outer DE Feder, außen FR Ressort, externe ES Muelle, exterior PT Mola externa para RU Пружина, внешн 	repl. ZF 0732 040 385	336 264 0693	02.20595 
				
4 S-150, 5 K-110, 5 S-110/111	<ul style="list-style-type: none"> EN Repair kit DE Reparatursatz FR Kit de réparation ES Kit de reparación PT Jogo reparo RU Ремонтный комплект 	repl. ZF 1295 298 976		02.23179 
				
4 S-150, 5 K-110, 5 S-110/111	<ul style="list-style-type: none"> EN Repair kit DE Reparatursatz FR Kit de réparation ES Kit de reparación PT Jogo reparo RU Ремонтный комплект 			02.23179 
				
4 S-150, 5 K-110, 5 S-110/111	<ul style="list-style-type: none"> EN Plunger DE Druckstück FR Pièce de serrage ES Pieza de presión PT Êmbolo RU Упор 	repl. ZF 1269 328 234	000 263 0140	02.20572 
				

THE ORIGINAL NUMBERS OF THE VEHICLE MANUFACTURER MAY BE USED FOR COMPARISON PURPOSES ONLY AND MUST NOT BE MENTIONED ON INVOICES TO VEHICLE OWNERS.

Application	Description	Details	Ref.	Erqo No.
4 S-150, 5 K-110, 5 S-110/111	<ul style="list-style-type: none"> EN Spring, inner DE Feder, innen FR Ressort, interne ES Muelle, interior PT Mola, interna RU Пружина, внутр 	repl. ZF 0732 040 929	003 993 9201	02.22538 
				
4 S-150, 5 K-110, 5 S-110/111	<ul style="list-style-type: none"> EN Spring, outer DE Feder, außen FR Ressort, externe ES Muelle, exterior PT Mola, externa para RU Пружина, внешн. 	repl. ZF 0732 040 736	002 993 7501	02.22537 
				
BM 717/719	<ul style="list-style-type: none"> EN Repair kit DE Reparatursatz FR Kit de réparation ES Kit de reparación PT Jogo reparo RU Ремонтный комплект 		343 264 0993 S	02.23180 
5 S 110, 5 S 111				
BM 717/719	<ul style="list-style-type: none"> EN Repair kit DE Reparatursatz FR Kit de réparation ES Kit de reparación PT Jogo reparo RU Ремонтный комплект 		002 993 1801 S	02.23181 
5 S 110, 5 S 111				
BM 710/715, 717/719	<ul style="list-style-type: none"> EN Ball DE Kugel FR Bille ES Bola PT Esfera trambulador RU Шар 	Ø 6 mm	005401 306000	02.22865 
				

THE ORIGINAL NUMBERS OF THE VEHICLE MANUFACTURER MAY BE USED FOR COMPARISON PURPOSES ONLY AND MUST NOT BE MENTIONED ON INVOICES TO VEHICLE OWNERS.

Application	Description	Details	Ref.	Erqo No.
BM 717/719	<ul style="list-style-type: none"> EN Spring DE Feeler FR Ressort ES Muelle PT Mola espiral RU Пружина 		343 264 0993	02.20597 
				
3 BM 717/719	<ul style="list-style-type: none"> EN Spring DE Feder FR Ressort ES Muelle PT Mola espiral RU Пружина 		002 993 1801	02.22534 
				
16 S 130,16 S 160	<ul style="list-style-type: none"> EN Nut DE Mutter FR Ecrou ES Tuerca PT Porca RU Гайка 	repl. ZF 0737 502 092	000 990 2360	02.22478 
				
BM 717/719	<ul style="list-style-type: none"> EN Grooved nut DE Nutmutter FR Ecrou à gorge ES Tuerca ranurada PT Porca ranhurada RU Шлицевая гайка 		000 990 1360	02.22477 
				
BM 714/715	<ul style="list-style-type: none"> EN Nut DE Mutter FR Ecrou ES Tuerca PT Porca RU Гайка 		945 990 0050	02.22472 
				
BM 710/714/715, 717/718/719	<ul style="list-style-type: none"> EN Lock DE Sicherung FR Tôle arrêtoir ES Seguro PT Mola RU Предохранитель 	repl. ZF 1250 304 353	385 994 1032	02.22563 
AK 6-80, G 3-90, S 6-80, 4S-150, 5 K-91/110, 5S-90/110/111				
				









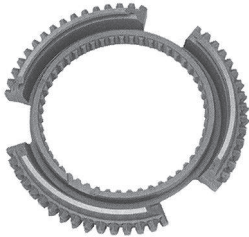

THE ORIGINAL NUMBERS OF THE VEHICLE MANUFACTURER MAY BE USED FOR COMPARISON PURPOSES ONLY AND MUST NOT BE MENTIONED ON INVOICES TO VEHICLE OWNERS.

Application	Description	Details	Ref.	Erqo No.
BM 717/719 5 K-91/110, 5 S-90/110/111, 16 S-160, 16 S-190	<ul style="list-style-type: none"> EN Lock DE Sicherung FR Tôle arrêtoir ES Seguro PT Mola RU Предохранитель 	repl. ZF 1269 302 164	000 264 0273	02.20588 
				
16 S 130,16 S 160	<ul style="list-style-type: none"> EN Tab washer DE Sicherung FR Tôle arrêtoir ES Seguro PT Arruela algema RU Предохранитель 		000 264 0973	02.20589 
				
BM 714/715	<ul style="list-style-type: none"> EN Spring DE Feder FR Ressort ES Muelle PT Mola espiral RU Пружина 		387 262 0893	02.20567 
				
BM 714/715	<ul style="list-style-type: none"> EN Spring DE Feder FR Ressort ES Muelle PT Mola espiral RU Пружина 		387 262 1093	02.20568 
				
BM 714/715	<ul style="list-style-type: none"> EN Spring DE Feder FR Ressort ES Muelle PT Mola RU Пружина 		389 262 0293	02.20569 
				



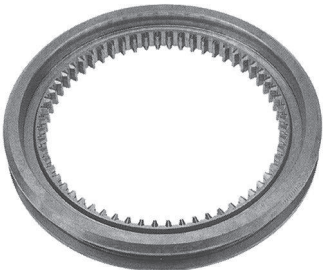

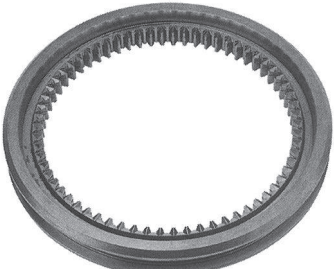

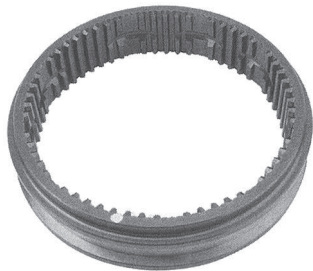

THE ORIGINAL NUMBERS OF THE VEHICLE MANUFACTURER MAY BE USED FOR COMPARISON PURPOSES ONLY AND MUST NOT BE MENTIONED ON INVOICES TO VEHICLE OWNERS.

Application	Description	Details	Ref.	Erqo No.
G 210/240	<ul style="list-style-type: none"> EN Gear DE Zahnrad FR Roue dentée ES Rueda dentada PT Engrenagem RU Зубчатое колесо 		945 262 4110	02.20519 
S 6-80, 4S-150, 5 S-90/110/111	<ul style="list-style-type: none"> EN Synchronizer ring DE Synchronring FR Bague de synchronisation ES Anillo sincronizador PT Disco acoplamento RU Блокирующее кольцо 		000 262 1334	02.20533 
G 210/240	<ul style="list-style-type: none"> EN Synchronizer ring DE Synchronring FR Cône de synchroniseur ES Cono de sincronización PT Anel sincronizador RU Блокирующее кольцо 		389 262 5434	02.20539 
G 125/135/155/180, G 200/210/240	<ul style="list-style-type: none"> EN Synchronizer ring DE Synchronring FR Cône de synchroniseur ES Cono de sincronización PT Anel sincronizador RU Блокирующее кольцо 		945 262 0434	02.20542 
G 155/180, G 200/210/240	<ul style="list-style-type: none"> EN Synchronizer ring DE Synchronring FR Cône de synchroniseur ES Cono de sincronización PT Anel sincronizador RU Блокирующее кольцо 		945 262 0534	02.20543 



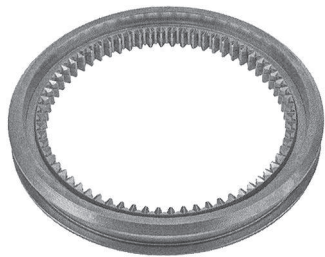

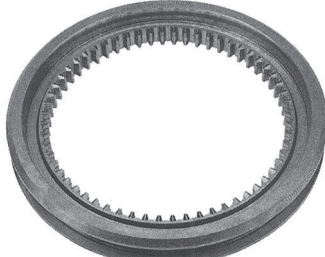
THE ORIGINAL NUMBERS OF THE VEHICLE MANUFACTURER MAY BE USED FOR COMPARISON PURPOSES ONLY AND MUST NOT BE MENTIONED ON INVOICES TO VEHICLE OWNERS.

Application	Description	Details	Ref.	Erqo No.
GV 4/95, G/GV4/110, G 125/135/155/180, G 200/210/240	<ul style="list-style-type: none"> EN Synchronizer cone DE Synchronring FR Bague de synchronisation ES Anillo sincronizador PT Cone sincronizador RU Блокирующее кольцо 		389 262 0637	02.20548 
GV 4/95, G/GV4/110, G125/135/155/180, G 200	<ul style="list-style-type: none"> EN Synchronizer ring DE Synchronring FR Bague de synchronisation ES Anillo sincronizador PT Disco acoplamento RU Блокирующее кольцо 		389 262 5634	02.20540 
16 S 112,16 S 130, 16 S 160,16 S 190	<ul style="list-style-type: none"> EN Synchronizer ring DE Synchronring FR Bague de synchronisation ES Anillo sincronizador PT Disco acoplamento RU Блокирующее кольцо 		000 262 3734	02.20534 
G 210/240	<ul style="list-style-type: none"> EN Sliding sleeve DE Schiebemuffe FR Coulisseau ES Anillo sincronizador PT Luva sincronizado RU Скользящая муфта 		945 262 2823	02.20531 
G 210/240	<ul style="list-style-type: none"> EN Sliding sleeve DE Schiebemuffe FR Coulisseau ES Anillo sincronizador PT Luva sincronizado RU Скользящая муфта 		945 262 2723	02.20530 







THE ORIGINAL NUMBERS OF THE VEHICLE MANUFACTURER MAY BE USED FOR COMPARISON PURPOSES ONLY AND MUST NOT BE MENTIONED ON INVOICES TO VEHICLE OWNERS.

Application	Description	Details	Ref.	Erqo No.
4 S 150, 5 S 90/92, 5 S 110/111, S 6-80/90	<ul style="list-style-type: none"> EN Sliding sleeve DE Schiebemuffe FR Coulisseau ES Anillo sincronizador PT Luva sincronizado RU Скользящая муфта 		000 262 1923	02.20520 
Sample				
G 125/135/155/180, G 200	<ul style="list-style-type: none"> EN Sliding sleeve DE Schiebemuffe FR Coulisseau ES Anillo sincronizador PT Luva sincronizado RU Скользящая муфта 		389 262 3023	02.20526 
G 125/135/155/180, G 200	<ul style="list-style-type: none"> EN Sliding sleeve DE Schiebemuffe FR Coulisseau ES Anillo sincronizador PT Luva sincronizado RU Скользящая муфта 		389 262 2923	02.20525 
G 125/135/155/180, G 200/210/240	<ul style="list-style-type: none"> EN Sliding sleeve DE Schiebemuffe FR Coulisseau ES Anillo sincronizador PT Luva sincronizado RU Скользящая муфта 		389 262 1723	02.20523 
Sample				

THE ORIGINAL NUMBERS OF THE VEHICLE MANUFACTURER MAY BE USED FOR COMPARISON PURPOSES ONLY AND MUST NOT BE MENTIONED ON INVOICES TO VEHICLE OWNERS.

Application	Description	Details	Ref.	Erqo No.
16 S 112,16 S 130, 16 S 160,16 S 190	<ul style="list-style-type: none"> EN Sliding sleeve DE Schiebemuffe FR Coulisseau ES Anillo sincronizador PT Luva sincronizado RU Скользящая муфта 		000 262 3623	02.20521 
				Sample
4 S 150, 5 S 90/92, 5 S 110/111, S 6-80/90	<ul style="list-style-type: none"> EN Follower DE Mitnehmer FR Entraîneur ES Pieza de arrastre PT Engate RU Поводок 	repl. ZF 1250 304 351	000 262 0340	02.20550 
				Sample
16 S 112,16 S 130, 16 S 160, 16S 190	<ul style="list-style-type: none"> EN Follower DE Mitnehmer FR Entraîneur ES Pieza de arrastre PT Engate RU Поводок 		000 262 1940	02.20552 
				Sample
5 S 111	<ul style="list-style-type: none"> EN Follower DE Mitnehmer FR Entraîneur ES Pieza de arrastre PT Engate RU Поводок 		000 262 1240	02.20551 
				Sample
G 210/240	<ul style="list-style-type: none"> EN Synchronizer hub DE Synchronkörper FR Corps synchronisé ES Cuerpo sincronizador PT Cubo acionamento RU Синхронизатор 		389 262 4735	02.20545 

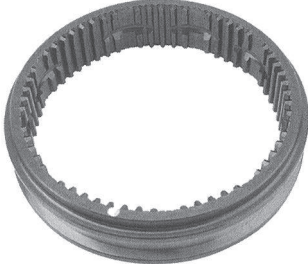
THE ORIGINAL NUMBERS OF THE VEHICLE MANUFACTURER MAY BE USED FOR COMPARISON PURPOSES ONLY AND MUST NOT BE MENTIONED ON INVOICES TO VEHICLE OWNERS.

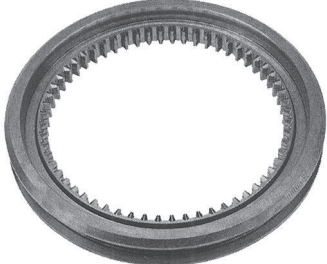
Application	Description	Details	Ref.	Erqo No.
G 125/135/155/180, G 200/210/240	<ul style="list-style-type: none"> EN Synchronizer ring DE Synchronring FR Bague de synchronisation ES Anillo sincronizador PT Disco acoplamento RU Блокирующее кольцо 		945 260 0850	02.20463 
				
G 125/135/155/180, G 200/210/240	<ul style="list-style-type: none"> EN Sliding sleeve DE Schiebemuffe FR Coulisseau ES Anillo sincronizador PT Luva sincronizado RU Скользящая муфта 		945 262 0823	02.20529 
				
				Sample
4 S 150, 5 S 110/111, 5 K 110/111	<ul style="list-style-type: none"> EN Sliding sleeve DE Schiebemuffe FR Coulisseau ES Anillo sincronizador PT Luva sincronizado RU Скользящая муфта 	repl. ZF 1269 333 047	000 262 4123	02.20522 
				
				Sample
16 S 112,16 S 130, 16 S 160,16 S 190 326	<ul style="list-style-type: none"> EN Collar DE Muffe FR Manchon ES Manguito PT Casquilho RU Муфта 		000 263 0523	02.20571 
				
				Sample

Application	Description	Details	Ref.	Erqo No.
BM 714/715 G 125/155/180, G 200	<ul style="list-style-type: none"> EN Synchronizer ring DE Synchronring FR Synchroniseur ES Anillo sincronizador PT Disco acoplamento RU Блокирующее кольцо 		389 262 4034	02.23182 
G 125/135/155/180, G 200/210/240	<ul style="list-style-type: none"> EN Synchronizer hub DE Synchronkörper FR Corps synchronisé ES Cuerpo sincronizador PT Cubo acionamento RU Синхронизатор 		389 262 4935	02.20546 
16 S 112, 16 S 130, 16 S 160, 16 S 190	<ul style="list-style-type: none"> EN Coupling cone DE Kupplungskonus FR Cône de synchro ES Cono de acoplamiento PT Caixa embreagem RU Конус муфты 		000 263 1720	02.20570 
G 125/135/155/180, G 200/210/240	<ul style="list-style-type: none"> EN Coupling cone DE Kupplungskonus FR Cône de synchro ES Cono de acoplamiento PT Caixa embreagem RU Конус муфты 		389 260 2036	02.20460 
BM 710, 717, 718	<ul style="list-style-type: none"> EN Screw DE Schraube FR Vis ES Tornillo PT Parafuso RU Болт 	M 10 x 30	000933 010087	02.22824 
				

THE ORIGINAL NUMBERS OF THE VEHICLE MANUFACTURER MAY BE USED FOR COMPARISON PURPOSES ONLY AND MUST NOT BE MENTIONED ON INVOICES TO VEHICLE OWNERS.

Application	Description	Details	Ref.	Erqo No.
BM 717, 719	<ul style="list-style-type: none">EN ScrewDE SchraubeFR VisES TornilloPT ParafusoRU Болт	M 12 x 30	000933 012068	02.22825 











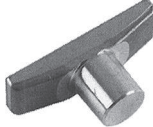

Shifting Fork

Schaltgabel • Fouche Transmission • Rieles de Cambio / Horquillas de Mando
Garfo Troca de Marcha • Вилка переключения передач

Application	Description	Details	Ref.	Erqo No.
BM 717/718/719 S 6-90, 5 S 110, 5 S 111, 4 S 150	EN Bolt DE Bolzen FR Boulon ES Perno PT Parafuso RU Болт	M 24 x 1,5 x 45,5	000 265 0971	02.20609 
BM 719 AK 6-90	EN Pin DE Bolzen FR Axe ES Perno PT Parafuso RU Болт	M 24 x 1,5 x 73	000 265 0271	02.20607 
BM 717/719 5 S 110, 5 S 111	EN Bolt DE Bolzen FR Boulon ES Perno PT Parafuso RU Болт	M 24 x 1,5 x 57	000 265 1171	02.20610 
BM 717/719 S 6-90, 5 S 110, 5 S 111, 4 S 150	EN Slider DE Gleitstück FR Pièce coulissante ES Patín PT Cachorrete RU Ползун		000 268 0149	02.20667 
BM 710/717/719 5 S 92, 5 S 110, 5 S 111, 16 S 112,16 S 130, 16 S 160,16 S 190	EN Slider DE Gleitstück FR Pièce coulissante ES Patín PT Cachorrete RU Ползун		000 268 0849	02.20671 
BM 717/718/719 4 S 150, 5 K 90/91, 5 S 90/91/92	EN Sliding block DE Gleitstück FR Coulisseau ES Corredera deslizante PT Cachorrete RU Ползун		000 268 0249	02.20668 

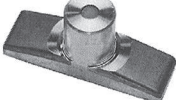
THE ORIGINAL NUMBERS OF THE VEHICLE MANUFACTURER MAY BE USED FOR COMPARISON PURPOSES ONLY AND MUST NOT BE MENTIONED ON INVOICES TO VEHICLE OWNERS.







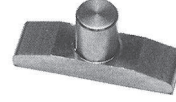

Application	Description	Details	Ref.	Erqo No.
BM 717/719 5 S 110, 5 S 111	<ul style="list-style-type: none"> EN Sliding block DE Gleitstück FR Coulisseau ES Patín PT Cachorrete RU Ползун 		000 268 0549	02.20669 
BM 710/717/719 5 S 110, 5 S 111, 16 S 112,16 S 130, 16 S 160,16 S 190	<ul style="list-style-type: none"> EN Sliding block DE Gleitstück FR Coulisseau ES Patín PT Cachorrete RU Ползун 		000 268 0649	02.20670 
BM 714/715 G 125/150, G 180/200	<ul style="list-style-type: none"> EN Slide DE Gleitstück FR Doigt de fourchette ES Patín PT Cachorrete RU Ползун 		389 265 2349	02.20601 
BM 714/715 G 125/150, G 180/200	<ul style="list-style-type: none"> EN Slide reverse DE Gleitstück FR Doigt de fourchette inverseur ES Patín marcha atrás PT Cachorrete marcha-tras RU Ползун фонарей заднего хода 		947 265 0249	02.20605 
BM 714/715 G 125/150, G 180/200	<ul style="list-style-type: none"> EN Sliding block DE Gleitstück FR Coulisseau ES Patín PT Cachorrete RU Ползун 		389 265 2449	02.20602 

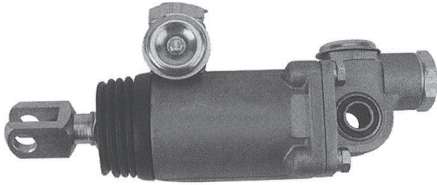
THE ORIGINAL NUMBERS OF THE VEHICLE MANUFACTURER MAY BE USED FOR COMPARISON PURPOSES ONLY AND MUST NOT BE MENTIONED ON INVOICES TO VEHICLE OWNERS.

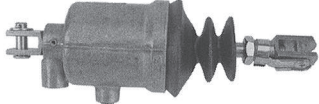
Shifting ForkSchaltgabel • Fouche Transmission • Rieles de Cambio / Horquillas de Mando
Garfo Troca de Marcha • Вилка переключения передач



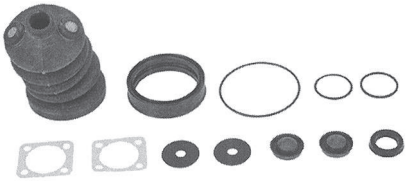

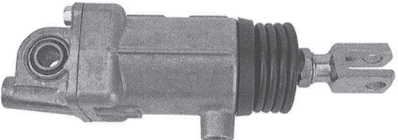
Application	Description	Details	Ref.	Erqo No.
BM 715 G 210/230/240	EN Slider DE Gleitstück FR Pièce coulissante ES Patín PT Cachorrete RU Ползун		947 265 0349	02.20606 











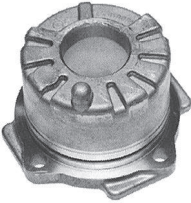

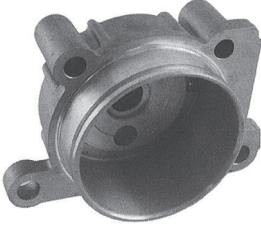

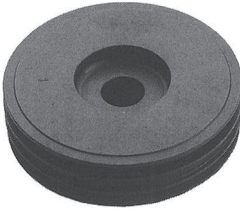





Application	Description	Details	Ref.	Erqo No.
BM 717/719 5 S 92, 5 S 110, 5 S 111	<ul style="list-style-type: none"> EN Shifting cylinder DE Schaltzylinder FR Vérin de commande ES Cilindro de mando PT Cilindro tirante garfo RU Цилиндр управления включением 	repl. ZF 0750 132 019	000 260 4663	02.20493 
				
BM 717/719 5 S 92, 5 S 110, 5S111	<ul style="list-style-type: none"> EN Shifting cylinder for power-take-off DE Schaltzylinder für Nebenantrieb FR Vérin de commande pour entraînement auxiliaire ES Cilindro de mando para transmisión adicional PT Cilindro tomada força para tomada de força RU Цилиндр управления включением для механизма отбора мощности 	repl. ZF 1238 123 401	000 260 6263	02.20495 
				
BM 717/719 5 S 92, 5 S 110, 5 S 111	<ul style="list-style-type: none"> EN Repair kit, shifting cylinder DE Reparatursatz, Schaltzylinder FR Kit de réparation, vérin de commande ES Kit de reparación, cilindro de mando PT Jogo reparo, cilindro tirante garfo RU Ремонтный комплект 	repl. Wabco 422 010 001 2	000 586 7726	02.22070 
				
BM 717/719 5 S 92, 5 S 110, 5 S 111	<ul style="list-style-type: none"> EN Repair kit, shifting cylinder DE Reparatursatz, Schaltzylinder FR Kit de réparation, vérin de commande ES Kit de reparación, cilindro de mando PT Jogo reparo, cilindro tirante garfo RU Ремонтный комплект 	repl. ZF 0501 298 046	000 260 3968	02.20499 
				
BM 714/717/719 5 S 110, 5 S 111, G 3/65, S 6-90 --gearbox 131010	<ul style="list-style-type: none"> EN Shifting cylinder DE Schaltzylinder FR Vérin de commande ES Cilindro de mando PT Cilindro alavanca caixa força RU Цилиндр управления включением 	repl. ZF 0750 132 009	000 260 4763	02.20494 
				

Shifting Cylinder

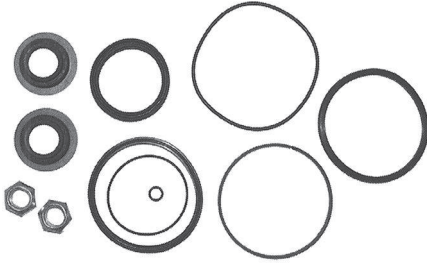



Schaltzylinder • Vérin de Commande • Cilindro de Mando
Cilindro transferencia • Рабочий цилиндр











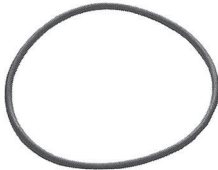

Application	Description	Details	Ref.	Erqo No.
BM 714/717/719 5 S 110, 5S111, G 3/65, S 6-90 --gearbox 131010	<ul style="list-style-type: none"> EN Repair kit, shifting cylinder DE Reparatursatz, Schaltzylinder FR Kit de réparation, vérin de commande ES Kit de reparación, cilindro de mando PT Jogo reparo, cilindro tirante garfo RU Ремонтный комплект 	repl.Wabco 422 010 000 2	000 586 0026	02.22069 
BM 714/717/719	<ul style="list-style-type: none"> EN Bushing DE Buchse FR Bague ES Casquillo PT Bucha RU Втулка 	repl. ZF 0634 308 009	000 268 4950	02.20674 
BM 717/719 4 S 150, 5 6-90, 5 S 110, 5 S 111	<ul style="list-style-type: none"> EN Bracket, shifting cylinder DE Halter, Schaltzylinder FR Support, vérin de commande ES Sujetador, cilindro de cambios PT Suporte, cilindro tirante garfo RU Кронштейн, Цилиндр управления включением 	repl.ZF 1229 201 016	000 260 0162	02.20487 
BM 710/717 16 S 112,16 S 130, 16 S 160,1 6 S 190	<ul style="list-style-type: none"> EN Cylinder housing DE Zylindergehäuse FR Carter de cylindre ES Alojamiento del cilindro PT Caneco Transferencia RU Корпус цилиндра 		000 267 0419	02.20618 
BM 710/717 16 S 112,16 S 130, 16 S 160,16 S 190	<ul style="list-style-type: none"> EN Shifting cylinder housing DE Schaltzylindergehäuse FR Cylindre de contrôle relais ES Alojamiento del cilindro, aluminio PT Caneco Transferencia RU Корпус рабочего цилиндра 		000 267 2119	02.20620 

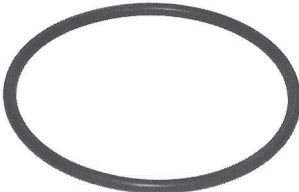
Application	Description	Details	Ref.	Erqo No.
BM 710/717/718 16 S 112, 16 S 130, 16 S 160, 16 S 190	<ul style="list-style-type: none"> EN Control cylinder split group DE Schaltzylinder Splitgruppe FR Vérin de commande étage ES Cilindro de mando grupo split PT Caneco reduzida gupo altas/baixas RU Цилиндр управления включением делителя 		000 267 0519	02.20619 
BM 714/715 G 125/155/180, G 200/210/240	<ul style="list-style-type: none"> EN Cylinder housing, aluminium planetary gear DE Zylindergehäuse, Aluminium Planetengetriebe FR Carter de cylindre, aluminium relais réducteur ES Alojamiento del cilindra, aluminio engranaje planetario PT Caneco Transferencia, aluminio planetário RU Корпус цилиндра, Алюминий планетарного механизма 		945 267 1119	02.20622 
BM 710/717 16 S 112,16 S 130, 16 S 160,16 S 190	<ul style="list-style-type: none"> EN Piston, control cylinder DE Kolben, Kontrollzylinder FR Piston, cylindre de contrôle ES Pistón, cilindro de control PT Êmbolo, cilindro controle RU Поршень, цилиндр управления 		000 267 0818	02.20614 
BM 710/717/718 16 S 112,16 S 130, 16 S 160,16 S 190	<ul style="list-style-type: none"> EN Piston, control cylinder split group DE Kolben, Kontrollzylinder Splitgruppe FR Piston, cylindre de contrôle ES Pistón, cilindro de control PT Êmbolo, cilindro controle RU Поршень, цилиндр управления 		000 267 0918	02.20615 
BM 714/715 G 125/155/180, G 200/210/240	<ul style="list-style-type: none"> EN Piston, control cylinder DE Kolben, Kontrollzylinder FR Piston, cylindre de contrôle ES Pistón, cilindro de control PT Êmbolo, cilindro controle RU Поршень, цилиндр управления 		945 267 0218	02.20617 

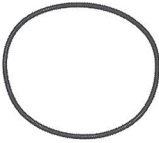
Application	Description	Details	Ref.	Erqo No.
BM 714/715 G 125/155/180, G 200/210/240	<p>EN Piston, control cylinder planetary gear</p> <p>DE Kolben, Kontrollzylinder Planetengetriebe</p> <p>FR Piston, cylindre de contrôle relais réducteur</p> <p>ES Pistón, cilindro de control engranaje planetario</p> <p>PT Êmbolo, cilindro controle planetário</p> <p>RU Поршень, цилиндр управления планетарного механизма</p>		389 267 1018	02.20616 
BM 710/717 16 S 112, 16 S 130, 16 S 160, 16 S 190	<p>EN Gasket kit</p> <p>DE Dichtsatz</p> <p>FR Kit de joints</p> <p>ES Juego de juntas</p> <p>PT Jogo junta</p> <p>RU Комплект уплотнителей</p>		000 267 0697 S2	02.23183 
BM 710/717/718 16 S 112, 16 S 130, 16 S 160, 16 S 190	<p>EN Gasket kit split group</p> <p>DE Dichtringsatz</p> <p>FR Kit de joints étage</p> <p>ES Juego de juntas grupo split</p> <p>PT Jogo junta grupo altas/baixas</p> <p>RU Комплект уплотнительных колец делителя</p>		000 267 0697 S3	02.23184 
BM 714/715 G 125/155/180, G 200/210/240	<p>EN Repair kit planetary gear</p> <p>DE Reparatursatz Planetengetriebe</p> <p>FR Kit de réparation relais réducteur</p> <p>ES Kit de reparación engranaje planetario</p> <p>PT Jogo reparo planetário</p> <p>RU Ремонтный комплект планетарного механизма</p>		000 267 0197 S2	02.23185 

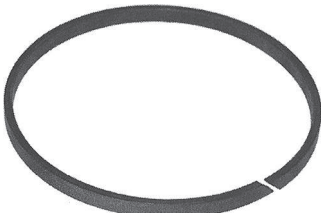
THE ORIGINAL NUMBERS OF THE VEHICLE MANUFACTURER MAY BE USED FOR COMPARISON PURPOSES ONLY AND MUST NOT BE MENTIONED ON INVOICES TO VEHICLE OWNERS.

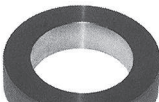







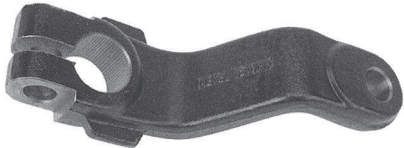

Application	Description	Details	Ref.	Erqo No.
BM 710/717 16 S 112,16S 130, 16 S 160, 16 S 190	<ul style="list-style-type: none"> EN Oil seal DE Wellendichtring FR Joint speed ES Anillo retén PT Anel retenção RU Сальник 	25 x 38 x 14,5	000 267 0697	02.20642 
BM 714/715 G 125/155/180, G 200/210/240	<ul style="list-style-type: none"> EN Boot DE Manschette FR Manchon ES Retén PT Anel vedação RU Манжета 		000 267 0197	02.20640 
BM 710/717 16 S 112,16 S 130, 16 S 160,16 S 190	<ul style="list-style-type: none"> EN Seal ring DE Dichtring FR Bague d'étanchéité ES Retén PT Anel Caneco Transferência RU Уплотнительное кольцо 		000 267 0997	02.20643 
BM 714/715 G 125/155/180, G 200/210/240	<ul style="list-style-type: none"> EN Seal ring DE Dichtring FR Bague d'étanchéité ES Retén PT Anel vedação alavanca interna RU Уплотнительное кольцо 	41 x 48 x 11,7 mm	006 997 6447	02.22660 
BM 714/715 G 125/155/180, G 200/210/240	<ul style="list-style-type: none"> EN Seal ring DE Dichtring FR Bague d'étanchéité ES Retén PT Anel Caneco Transferência RU Уплотнительное кольцо 	80 x 90 x 17 mm	024 997 8347	02.22702 

Application	Description	Details	Ref.	Erqo No.
BM 710/717 16 S 112, 16 S 130, 16 S 160, 16 S 190	EN Seal ring DE Dichtring FR Bague d'étanchéité ES Retén PT Anel Caneco Transferência RU Уплотнительное кольцо		016 997 3747	02.22688 
BM 710/717/718 16 S 112, 16 S 130, 16 S 160, 16 S 190	EN Seal ring DE O-Ring FR Bague d'étanchéité ES Retén PT Anel vedação caneca reduzida RU Уплотнительное кольцо	81,0 x 3,0 mm 	009 997 1948	02.22712 
BM 714/715 G 125/155/180, G 200/210/240	EN O-ring DE O-Ring FR Joint torique ES Junta tórica PT Anel RU Уплотнительное кольцо	62,5 x 3,0 mm 	007 997 4248	02.22709 
BM 714/715 G 125/155/180, G 200/210/240	EN O-ring DE O-Ring FR Joint torique ES Junta tórica PT Anel RU Уплотнительное кольцо	90,0 x 3,0 mm 	013 997 7548	02.22717 
BM 710/717 16 S 112, 16 S 130, 16 S 160, 16 S 190	EN Seal ring DE Dichtring FR Bague d'étanchéité ES Retén PT Anel vedação caneca reduzida RU Уплотнительное кольцо		000 267 1059	02.20633 
BM 714/715 G 125/155/180, G 200/210/240	EN Bushing DE Buchse FR Bague ES Casquillo PT Bucha RU Втулка		387 267 0650	02.20632 





THE ORIGINAL NUMBERS OF THE VEHICLE MANUFACTURER MAY BE USED FOR COMPARISON PURPOSES ONLY AND MUST NOT BE MENTIONED ON INVOICES TO VEHICLE OWNERS.

Application	Description	Details	Ref.	Erqo No.
GM 717/718/719	<ul style="list-style-type: none"> EN Ball joint DE Kugel köpf FR Rotule ES Rótula PT Articulação alavanca RU Шариковый шарнир 	M 14 x 1,5; L=85 mm ;RHT	000 268 4889	02.20691 
3 GM 710/717/718/719	<ul style="list-style-type: none"> EN Ball joint, right hand thread DE Kugelgelenk, Rechtsgewinde FR Rotule, filetage à droite ES Rótula, rosca derecha PT Articulação alavanca, rosca direita RU Шариковый шарнир, Правая резьб; 	M 14 x 1,5; L=85 mm ; RHT	000 268 5289	02.20692 
GM 710/717/718/719	<ul style="list-style-type: none"> EN Ball joint, upper DE Kugelgelenk, oben FR Rotule, supérieur ES Rótula, superior PT Articulação alavanca, superior RU Шариковый шарнир, верхн. 	M 12 x 1,75 ; M 10 x 1,5 ; L=55mm LHT	000 268 6189	02.20694 
GM 710/717/718/719	<ul style="list-style-type: none"> EN Ball joint, lower DE Kugelgelenk, unten FR Rotule, inférieur ES Rótula, inferior PT Articulação alavanca, inferior RU Шариковый шарнир, нижн. 	M 12 x 1,75; M 10 x 1,5 ; L=55mm RHT	000 268 6289	02.20695 
GM 710/717	<ul style="list-style-type: none"> EN Ball joint DE Kugelgelenk FR Rotule ES Rótula PT Articulação alavanca RU Шариковый шарнир 	M 12 x 1,75 ; M 10 x 1,5 ; L=55mm RHT	000 268 6389	02.20696 
BM 710/717 16 S 112, 16 S 130, 16 S 160,16 S 190	<ul style="list-style-type: none"> EN Thread rod DE Gewindestange FR Tige filetée ES Barra roscada PT Pino roscado RU Нарезная штанга 		900331 012338	02.22950 

THE ORIGINAL NUMBERS OF THE VEHICLE MANUFACTURER MAY BE USED FOR COMPARISON PURPOSES ONLY AND MUST NOT BE MENTIONED ON INVOICES TO VEHICLE OWNERS.













Application	Description	Details	Ref.	Erqo No.
BM 710/717/718 16 S 112, 16 S 130, 16 S 160, 16 S 190	<ul style="list-style-type: none"> EN Bracket DE Halter FR Support ES Sujeción PT Suporte RU Кронштейн 		000 268 2640	02.20654 
BM 717/718/719 5 S 110, 5 S 111, S 6-90, 16 S 130, 4 S 150	<ul style="list-style-type: none"> EN Lever DE Hebel FR Levier ES Palanca PT Alavanca RU Рычаг 	repl. ZF 1295 307 541 	000 268 4130	02.20649 
BM 717/719 5 S / K 110 GPA (gb 131098 --), 5 S 90	<ul style="list-style-type: none"> EN Lever DE Hebel FR Levier ES Palanca PT Alavanca RU Рычаг переключения 	repl. ZF 1250 307 515 	000 268 0630	02.20648 
BM 710/717/718 16 S 112, 16 S 130, 16 S 160, 16 S 190	<ul style="list-style-type: none"> EN Gear shift lever DE Schalthebel FR Levier de vitesses ES Palanca de cambios PT Alavanca RU Рычаг переключения 		000 265 2031	02.20599 
BM 710/717 16 S 112, 16 S 130, 16 S 160, 16 S 190	<ul style="list-style-type: none"> EN Gear shift lever DE Schalthebel FR Levier de vitesses ES Palanca de cambios PT Alavanca RU Рычаг переключения 		000 265 1831	02.20598 

THE ORIGINAL NUMBERS OF THE VEHICLE MANUFACTURER MAY BE USED FOR COMPARISON PURPOSES ONLY AND MUST NOT BE MENTIONED ON INVOICES TO VEHICLE OWNERS.













Application	Description	Details	Ref.	Erqo No.
BM 710/717 16 S 112,16 S 130, 16 S 160, 16 S 190	<ul style="list-style-type: none"> EN Lever DE Hebel FR Levier ES Palanca PT Alavanca RU Рычаг 		000 268 1528	02.20646 
3 BM 717/719 5 S 110, 5 S 111	<ul style="list-style-type: none"> EN Shaft DE Welle FR Arbre ES Eje PT Eixo RU Вал 		000 268 2332	02.20651 
BM 710/717/718 16 S 112,16S 130, 16 S 160	<ul style="list-style-type: none"> EN Gear shift shaft DE Schaltwelle FR Arbre de commande ES Barra de Mando del cambio PT Eixo caixa mudança RU Вал управления переключением передач 		000 267 0503	02.20612 
BM 710/717 16 S 112,16 S 130, 16 S 160,16 S 190	<ul style="list-style-type: none"> EN Gear shift shaft DE Schaltwelle FR Arbre de commande ES Barra de Mando del cambio PT Eixo caixa mudança RU Вал управления 		000 267 0803	02.20613 
BM 710/717/718/719	<ul style="list-style-type: none"> EN Roller DE Rolle FR Galet ES Rodillo PT Roldana RU Ролик 	repl. ZF 0735 470 007 	336 268 0038	02.20653 
BM 717/719 S 6-90, 4 S 150, 5 S 110, 5 S 111	<ul style="list-style-type: none"> EN Bolt DE Bolzen FR Boulon ES Perno PT Pino arrastador RU Болт 	repl. ZF 1272 307 024 	000 268 3174	02.20681 

Application	Description	Details	Ref.	Erqo No.
BM 717/719 4 S 150, 5 S 110, 5 S 111	EN Follower DE Mitnehmer FR Entraîneur ES Pieza de arrastre PT Engate pino arrastador RU Поводок	repl.ZF 1269 307 463	000 268 0643	02.20659 
BM 710/717/718 16 S 112, 16 S 130, 16 S 160, 16 S 190	EN Washer DE Scheibe FR Rondelle ES Arandela PT Arruela polia RU Шайба		000 267 1176	02.20638 
BM 710/717 16 S 112, 16 S 130, 16 S 160, 16 S 190	EN Screw and nut DE Schraube mit Mutter FR Vis et écrou ES Tornillo con tuerca PT Parafuso com porca RU Болт с гайкой		000 990 3077 S	02.23186 
BM 710/717 16 S 112, 16 S 130, 16 S 160, 16 S 190	EN Screw DE Schraube FR Vis ES Tornillo PT Parafuso RU Болт		000 990 3077	02.22500 
BM 710/717 16 S 112, 16 S 130, 16 S 160, 16 S 190	EN Nut DE Mutter FR Ecrou ES Tuerca PT Porca RU Гайка		308675 012000	02.22940 
BM 717/718/719 S 6-90, 4 S 150, 5 K 92, 5 S 110, 5 S 111	EN Follower DE Mitnehmer FR Entraîneur ES Pieza de arrastre PT Engate RU Поводок	repl. ZF 1240 307 338	336 268 0143	02.20665 

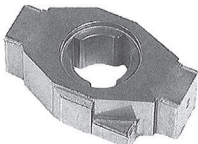



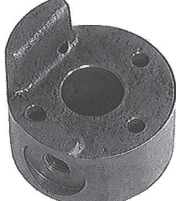





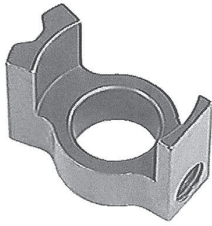

THE ORIGINAL NUMBERS OF THE VEHICLE MANUFACTURER MAY BE USED FOR COMPARISON PURPOSES ONLY AND MUST NOT BE MENTIONED ON INVOICES TO VEHICLE OWNERS.

Application	Description	Details	Ref.	Erqo No.
BM 717/719 4 S 150, 5 K 92, 5 S 110, 5 S 111	<ul style="list-style-type: none"> EN Follower DE Mitnehmer FR Entraîneur ES Pieza de arrastre PT Engate RU Поводок 	repl. ZF 1272 307 026	000 268 1743	02.20664 
				
3 BM 717/719 4 S 150, 5 S 90, 5 S 110, 5 S 111	<ul style="list-style-type: none"> EN Follower DE Mitnehmer FR Entraîneur ES Pieza de arrastre PT Engate RU Поводок 	repl. ZF 1269 307 431	000 268 1343	02.20662 
				
BM 717/719 4 S 150, 5 S 90, 5 S 110, 5 S 111	<ul style="list-style-type: none"> EN Follower DE Mitnehmer FR Entraîneur ES Pieza de arrastre PT Engate RU Поводок 	repl. ZF 1269 307 458	000 268 1543	02.20663 
				
BM 717/719 4 S 150, 5 S 90, 5 S 110, 5 S 111	<ul style="list-style-type: none"> EN Follower DE Mitnehmer FR Entraîneur ES Pieza de arrastre PT Engate RU Поводок 	repl. ZF 1269 307 456	000 268 0743	02.20660 
				
BM 719 5 S / K 110	<ul style="list-style-type: none"> EN Follower DE Mitnehmer FR Entraîneur ES Pieza de arrastre PT Engate RU Поводок 		000 268 1143	02.20661 
				
BM 710/717/718 16 S 112, 16 S 130, 16 S 160, 16 S 190	<ul style="list-style-type: none"> EN Follower DE Mitnehmer FR Entraîneur ES Pieza de arrastre PT Engate RU Поводок 		000 267 0043	02.20625 
				

THE ORIGINAL NUMBERS OF THE VEHICLE MANUFACTURER MAY BE USED FOR COMPARISON PURPOSES ONLY AND MUST NOT BE MENTIONED ON INVOICES TO VEHICLE OWNERS.

Application	Description	Details	Ref.	Erqo No.
BM 710/717/718 16 S 112,16 S 130, 16 S 160,16 S 190	EN Locking piece DE Anschlagstück FR Pièce de verrouillage ES Pieza de tope PT Chapa trava RU Упор		000 267 0346	02.20627 
BM 710/717/718 16 S 112,16 S 130, 16 S 160, 16 S 190	EN Cylindrical pin DE Zylinderstift FR Tige de cylindre ES Pasador cilíndrico PT Pino cilíndrico RU Цилиндрический штифт		000 991 4560	02.22529 
BM 717/719 4 S 150, 5 6-90, 5 S 90, 5 S 110, 5 5111	EN Detent segment DE Rastensegment FR Segment à crans ES Segmento de muescas PT Segmento RU Сектор со стопорными пазами	repl. ZF 1240 307 421 	000 268 0446	02.20666 
BM 710/717/718 16 S 112,16 S 130, 16 S 160, 16 S 190	EN Lock DE Anschlag FR Verrou ES Tope PT Trava RU Упор		000 267 2446	02.20629 
BM 710/717/718 16 S 112, 16 S 130, 16 S 160,16 S 190	EN Detent part DE Schaltsegment FR Segment de commande ES Segmento de mando PT Segmento RU Сегмент включения передачи		000 267 0046	02.20626 
BM 710/717/718 16 S 112,16 S 130, 16 S 160, 16 S 190	EN Detent part DE Schaltsegment FR Segment de commande ES Segmento de mando PT Segmento RU Сегмент включения передачи		000 267 1546	02.20628 

THE ORIGINAL NUMBERS OF THE VEHICLE MANUFACTURER MAY BE USED FOR COMPARISON PURPOSES ONLY AND MUST NOT BE MENTIONED ON INVOICES TO VEHICLE OWNERS.

Application	Description	Details	Ref.	Erqo No.
BM 710/717/718 16 S 112,16 S 130, 16 S 160,16 S 190	(EN) Detent part (DE) Schaltsegment (FR) Segment de commande (ES) Segmento de mando (PT) Guia eixo alavanca câmbio (RU) Сегмент включения передач		000 267 0347	02.20630 
3 BM 710/717/718/719	(EN) Bushing, shifting shaft (DE) Buchse, Schaltwelle (FR) Vague, arbre de transmission (ES) Casquillo, Árbol de cambios (PT) Bucha, eixo caixa mudança (RU) Втулка, Вал управления переключением передач	25,2 x 32 x 20 	000 268 2150	02.20672 
BM 717/719 4 S 150, 5 S 110, 5 S 111	(EN) Bushing (DE) Buchse (FR) Vague (ES) Casquillo (PT) Bucha (RU) Втулка		000 264 1150	02.20584 
GM 710/712/717/718, 719	(EN) Oil seal (DE) Wellendichtring (FR) Joint speed (ES) Anillo retén (PT) Retentor (RU) Сальник	25 x 35 x 7 	006 997 4946	02.22628 
GM 710/712/717/718, 719	(EN) Oil seal (DE) Wellendichtring (FR) Joint speed (ES) Anillo retén (PT) Capa protetora eixo tampa (RU) Сальник	25 x 35 x 7/10 	000 267 0296	02.20639 
BM 717/718/719 S 6-90, 5 K 110 --gearbox 131097	(EN) Shifting bolt (DE) Schaltbolzen (FR) Axe (ES) Perno de cambio (PT) Pino travante (RU) Вал	repl. ZF 1240 307 346 	336 268 0132	02.20652 

Application	Description	Details	Ref.	Erqo No.
BM 717/719 5 S 90, 5 S 110, 5 S 111 GPA gearbox 131098--	<ul style="list-style-type: none"> EN Locking pin DE Sperrstift FR Tige de serrage ES Espiga de bloqueo PT Pino travante RU Стопорный штифт 		000 268 1574	02.20677 
BM 717/719 5 S 110, 5 S 111 gearbox 131098-- gearbox 131454--	<ul style="list-style-type: none"> EN Shifting bolt DE Schaltbolzen FR Axe ES Perno de cambio PT Pino travante RU Болт с чекой 	repl. ZF 1269 307 424 	000 268 2874	02.20679 
BM 710/717/718 16 S 112, 16 S 130, 16 S 160, 16 S 190	<ul style="list-style-type: none"> EN Locking pin DE Sperrstift FR Tige de serrage ES Espiga de bloqueo PT Pino travante RU Стопорный штифт 		000 265 3974	02.20611 
BM 717/718/719	<ul style="list-style-type: none"> EN Spring DE Feder FR Ressort ES Muelle PT Mola espiral RU Пружина 		004 993 0801	02.22539 
BM 717/718/719	<ul style="list-style-type: none"> EN Spring DE Feder FR Ressort ES Muelle PT Mola espiral RU Пружина 		002 993 4301	02.22535 
BM 717/718/719	<ul style="list-style-type: none"> EN Spring DE Feder FR Ressort ES Muelle PT Mola espiral RU Пружина 		005 993 0401	02.22542 

THE ORIGINAL NUMBERS OF THE VEHICLE MANUFACTURER MAY BE USED FOR COMPARISON PURPOSES ONLY AND MUST NOT BE MENTIONED ON INVOICES TO VEHICLE OWNERS.

Application	Description	Details	Ref.	Erqo No.
BM 717/718/719	EN Spring DE Feder FR Ressort ES Muelle PT Mola espiral RU Пружина		004 993 9601	02.22541 
3 BM 717/719 5 S 90, 5 S 110, 5 S 111	EN Detent pin DE Rastenbolzen FR Boulon à cran ES Perno de retención PT Pino arraste RU Фиксатор	repl.ZF 1250 307 601 	000 268 3974	02.20682 
BM 717/719 AK 6-90, 5 S 110	EN Bolt DE Bolzen FR Axe ES Bulón PT Pino tampa lateral RU Болт		000 268 2274	02.20678 
BM 710/717/718 16 S 112, 16 S 130, 16 S 160, 16 S 190	EN Detent pin DE Rastenbolzen FR Boulon à cran ES Perno de retención PT Pino arraste RU Фиксатор	repl.ZF 1295 307 243 	000 267 0474	02.20636 
16S 130,16S 160	EN Bolt DE Bolzen FR Axe ES Bulón PT Parafuso RU Болт		000 267 0148	02.20631 
BM 717/719 5 S/K 90/92	EN Detent bush DE Rasterbuchse FR Douille à cran ES Casquillo de muescas PT Bucha RU Фиксирующая втулка		000 264 0148	02.20583 



Application	Description	Details	Ref.	Erqo No.
BM 717/719 5 S 90, 5 S 110, 5 S 111 gearbox 003529--	<ul style="list-style-type: none"> EN Detent pin DE Rastenbolzen FR Douille de commande ES Perno de retención PT Bucha RU Гнездо для подключения 	repl. ZF 1272 307 023	000 268 2550	02.20673 
BM 717/719 5 S 92, 5S110, 5 S 111. 4 S 150	<ul style="list-style-type: none"> EN Repair kit DE Reparatursatz FR Kit de réparation ES Kit de reparación PT Jogo reparo RU Ремонтный комплект 		000 268 0067 S3	02.23187 
BM 717/719 5 S 92, 5 S 110, 5 S 111. 4 S 150	<ul style="list-style-type: none"> EN Roller DE Seilrolle FR Galet ES Rodillo PT Roldana RU Тросовый шкив 		000 268 0067	02.20676 
BM 717/719 5 S 92, 5 S 110, 5S111, 4 S 150	<ul style="list-style-type: none"> EN Bolt DE Bolzen FR Boulon ES Perno PT Parafuso RU Болт 		000 268 2974	02.20680 
BM 717/719	<ul style="list-style-type: none"> EN Drain plug DE Verschlusschraube FR Bouchon de vidange ES Tapón roscado PT Vujão RU Резьбовая пробка 	M 22 x 1,5	001 997 5130	02.22590 
BM 717/718/719	<ul style="list-style-type: none"> EN Compression spring DE Druckfeder FR Ressort de serrage ES Resorte de compresión PT Mola compressão RU Нажимная пружина 		004 993 7701	02.22540 

THE ORIGINAL NUMBERS OF THE VEHICLE MANUFACTURER MAY BE USED FOR COMPARISON PURPOSES ONLY AND MUST NOT BE MENTIONED ON INVOICES TO VEHICLE OWNERS.



Application	Description	Details	Ref.	Erqo No.
OM 401 LA Euro I, OM 402 LA Euro I, OM 441 + LA, OM 442 + LA (motor 789374--) V 730, 731, 733 H 740, 741, 742, 744, 745, 746, 748 GM 710/717	<ul style="list-style-type: none"> EN Drain plug DE Verschlusschraube FR Bouchon de vidange ES Tapón roscado PT Bujão RU Резьбовая пробка 	M 24 x 1,5	352 997 0032	02.22599 
BM 717/718 16 S 112,16 S 130, 16 S 160,16 S 190	<ul style="list-style-type: none"> EN Gear shift housing DE Schaltgehäuse FR Carter commande ES Caja de cambio PT Controlo de marchas RU Картер коробки передач 		000 267 0820	02.20623 
BM 710/717/718 16 S 112,16 S 130, 16 S 160,16 S 190	<ul style="list-style-type: none"> EN Cover DE Abdeckung FR Couvercle ES Cubierta PT Tampa RU Крышка 		000 267 2022	02.20624 
BM 710/717/718 16S 112,16S 130, 16 S 160,16 S 190	<ul style="list-style-type: none"> EN Roller DE Rolle FR Galet ES Rodillo PT Rolo esférico RU Ролик 		000 267 0368	02.20634 
BM 710/717/718	<ul style="list-style-type: none"> EN Spring DE Feder FR Ressort ES Muelle PT Mola espiral RU Пружина 		002 993 6501	02.22536 

Application	Description	Details	Ref.	Erqo No.
BM 717/718/719 5 S 92, 5 S 110, 5 S 111, 4 S 150	EN Bleeder valve DE Entlüftungsventil FR Soupape de sécurité ES Válvula de ventilación PT Respiro tanque RU Воздушный клапан		336 264 0089	02.20594 
BM 714/715 G 125/150/180, G 200/210/240	EN Bolt DE Bolzen FR Axe ES Bulón PT Parafuso RU Болт		389 267 0974	02.20637 
BM 714/715 G 125/150/180, G 200/210/240	EN Bolt DE Bolzen FR Axe ES Bulón PT Parafuso RU Болт		945 268 0474	02.20686 
BM 714/715	EN Spring DE Feder FR Ressort ES Muelle PT Mola espiral RU Пружина		389 993 0501	02.22543 
BM 714 G 125/150/180 --gearbox 166617	EN Plug DE Verschlussdeckel FR Bouchon ES Tapa de cierre PT Tampa do bloqueio RU Крышка		389 261 0333	02.20508 
BM 714/715 G 125/150/180, G 200/210/240 gearbox 166618--	EN Plug DE Verschlussdeckel FR Bouchon ES Tapa de cierre PT Tampa do bloqueio RU Крышка		389 261 1733	02.20509 

THE ORIGINAL NUMBERS OF THE VEHICLE MANUFACTURER MAY BE USED FOR COMPARISON PURPOSES ONLY AND MUST NOT BE MENTIONED ON INVOICES TO VEHICLE OWNERS.



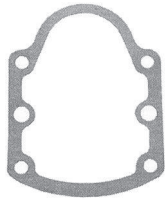







Application	Description	Details	Ref.	Erqo No.
BM 714/715/717/719 AK 6-80, S 6-80/90, G 3/65, G 3/90, G 4/65, G 4/95, G 4/110 GV 4/65, GV4/110, G 125/135/155/180, G 200/210/240, 4 S 150, 5 K 91/110, 5 S 90/110, 16 S 112/130/190	<ul style="list-style-type: none"> EN Needle bearing DE Nadellager FR Roulement à aiguilles ES Cojinete agujas PT Rolamento caixa RU Игольчатый подшипник 	repl. INA F-33791	005 981 3110	02.22363 
BM 714/715 G 4/65, G 4/95, G 4/110, GV 4/95, G 4/110, G125/135/155/180, G 200/210/240	<ul style="list-style-type: none"> EN Needle bearing DE Nadellager FR Roulement à aiguilles ES Rodamiento de agujas PT Rolamento agulha RU Игольчатый подшипник 	32 x 39 x 20 mm	009 981 0510	02.22373 
BM 714/715 G 4/65, G 4/95, G 4/110, GV 4/95, G 4/110, G 125/135/155/180, G 200/210/240	<ul style="list-style-type: none"> EN Needle bearing DE Nadellager FR Roulement à aiguilles ES Rodamiento de agujas PT Rolamento agulha RU Игольчатый подшипник 	38 x 45 x 20 mm	007 981 2110	02.22366 
BM 714 GV 4/110, G 125/135/155/180	<ul style="list-style-type: none"> EN Needle bearing DE Nadellager FR Roulement à aiguilles ES Rodamiento de agujas PT Rolamento agulha RU Игольчатый подшипник 	repl. INA HK 2820	013 981 4910	02.22386 
BM 714/715 G 125/155/180, G 200/210/240	<ul style="list-style-type: none"> EN Gasket DE Dichtung FR Joint ES Junta PT Junta RU Уплотнение 		389 268 1180	02.20687 

Shifting ShaftSchaltwelle • Arbre Transmission • Barra de Mando
Articulação do Controle de Marcha • Вал управления переключением передач

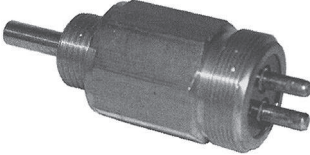





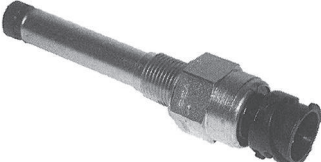

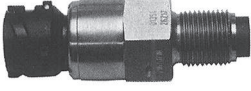

Application	Description	Details	Ref.	Erqo No.
BM 714/715	EN Gasket DE Dichtung FR Joint		389 268 1480	02.20688 
G 125/155/180, G 200/210/240	ES Junta PT Junta RU Уплотнение			

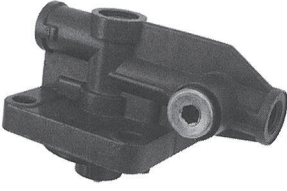

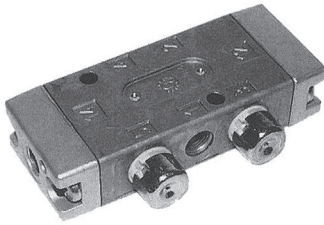



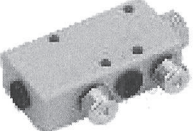

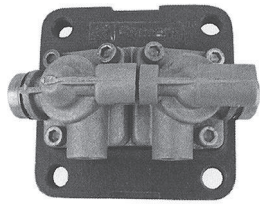

Application	Description	Details	Ref.	Erqo No.
GM 710/712/717/718, 719	<ul style="list-style-type: none"> EN Switch DE Schalter FR Commocio ES Interruptor PT Interruptor RU Включатель 	M 18 x 1,5 / M 27 x 1	003 545 1614	02.22001 
3 GM 712/713/714/715 BM 381/385/387/389, 393 BM 619/620/621/623, 624/625/645	<ul style="list-style-type: none"> EN Switch DE Schalter FR Commodo ES Interruptor PT Interruptor RU Включатель 	M 27 x 1 / M 12 x 1,5	000 545 7909	02.21973 
GM 712/713/714/715 BM 381/385/387/389, 393 BM 619/620/621/623, 625/645	<ul style="list-style-type: none"> EN Switch DE Schalter FR Commodo ES Interruptor PT Interruptor RU Включатель 	M 27 x 1 / M 12 x 1	001 545 2709	02.21981 
GM 711/712/714/715, 718/719 BM 387/389/391/393 BM 625 H 740/741/742/743, 744/745/746/748, 770	<ul style="list-style-type: none"> EN Switch DE Schalter FR Commodo ES Interruptor PT Interruptor RU Включатель 	M 18 x 1,5 / M 27 x 1	001 545 5709	02.21987 
GM 714/715	<ul style="list-style-type: none"> EN Switch DE Schalter FR Commodo ES Interruptor PT Interruptor RU Включатель 	M 12 x 1 / M 27 x 1	001 545 1209	02.21977 
GM 714/715	<ul style="list-style-type: none"> EN Switch DE Schalter FR Commodo ES Interruptor PT Interruptor RU Включатель 	M 12 x 1 / M 27 x 1	001 545 2809	02.21983 

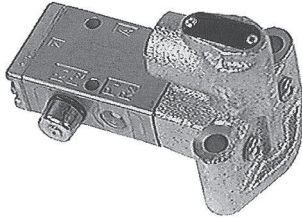
THE ORIGINAL NUMBERS OF THE VEHICLE MANUFACTURER MAY BE USED FOR COMPARISON PURPOSES ONLY AND MUST NOT BE MENTIONED ON INVOICES TO VEHICLE OWNERS.



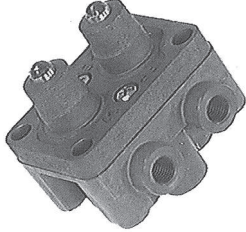

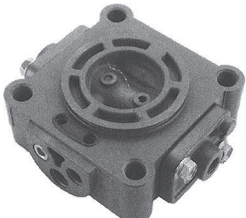





Application	Description	Details	Ref.	Erqo No.
GM 714/715	<ul style="list-style-type: none"> EN Switch DE Schalter FR Interrupteur ES Interruptor PT Interruptor RU Включатель 	M 20 x 1,5 / M 27 x 1	001 545 1309	02.21979 
				
GM 712/714/715	<ul style="list-style-type: none"> EN Switch DE Schalter FR Interrupteur ES Interruptor PT Interruptor RU Включатель 	M 20 x 1,5 / M 27 x 1	001 545 2909	02.21984 
				
GM 714	<ul style="list-style-type: none"> EN Switch DE Schalter FR Interrupteur ES Interruptor PT Interruptor RU Включатель 	M 18 x 1,5 / M 27 x 1	001 545 8114	02.21999 
				
BM 625/655/656/659	<ul style="list-style-type: none"> EN Temperature switch DE Temperaturschalter FR Capteur de température ES Sensor de temperatura PT Sensor temperatura RU Температурный датчик 	115 + -3°C / M 18 x 1,5	011 542 1817	02.21910 
				
GM 714/715	<ul style="list-style-type: none"> EN Impulse sensor DE Impulsgeber FR Emetteur d'impulsions ES Sensor de velocidad PT Transmissor pulso RU Индуктивный датчик 		006 542 8817	02.21902 
				
GM 710/715/721	<ul style="list-style-type: none"> EN Impulse sensor DE Impulsgeber FR Emetteur d'impulsions ES Sensor de velocidad PT Transmissor pulso RU Импульсный датчик 		012 542 4617	02.21914 
				

THE ORIGINAL NUMBERS OF THE VEHICLE MANUFACTURER MAY BE USED FOR COMPARISON PURPOSES ONLY AND MUST NOT BE MENTIONED ON INVOICES TO VEHICLE OWNERS.



Application	Description	Details	Ref.	Erqo No.
GM 711/712/714/715, 718/721/723	<ul style="list-style-type: none"> EN Impulse generator DE Impulsgeber FR Emetteur d'Impulsions ES Generador de impulsos PT Sensor impulso RU Импульсный датчик 		015 542 2417	02.21916 
GM 717/718/719	<ul style="list-style-type: none"> EN Inhibitor valve DE Sperrventil FR Clapet antiretour ES Válvula de bloqueo PT Válvula inibidora RU Запорный клапан 		001 260 2757	02.20475 
GM 717/718/719	<ul style="list-style-type: none"> EN 5/2 way valve DE 5/2 Wege Ventil FR Soupape 5/2 voies ES Válvula de 5/2 vías PT Válvula 5/2 vias RU 5/2-ходовой клапан 		000 260 1457	02.20464 
BM 710/717/718 16 S 112,16 S 130, 16 S 160,16 S 190	<ul style="list-style-type: none"> EN Valve DE Ventil FR Soupape ES Válvula PT Válvula RU Клапан 		001 260 6757	02.20480 
GM 714/715	<ul style="list-style-type: none"> EN Valve DE Ventil FR Soupape ES Válvula PT Válvula RU Клапан 		001 260 2057	02.20473 

Application	Description	Details	Ref.	Erqo No.
GM 717/719	<ul style="list-style-type: none"> EN Inhibitor valve DE Sperrventil FR Clapet antiretour ES Válvula de bloqueo PT Válvula inibidora RU Запорный клапан 		001 260 0257	02.20469 
GM 717/718/719	<ul style="list-style-type: none"> EN Clutch brake valve DE Ventil FR Valve de coupure ES Válvula PT Válvula embreagem RU Клапан 		001 260 1057	02.20471 
GM 710/717/718	<ul style="list-style-type: none"> EN Inhibitor valve DE Sperrventil FR Clapet antiretour ES Válvula de bloqueo PT Válvula inibidora RU Запорный клапан 		001 260 5957	02.20478 
GM 714/715	<ul style="list-style-type: none"> EN Inhibitor valve DE Sperrventil FR Clapet antiretour ES Válvula de bloqueo PT Válvula inibidora RU Запорный клапан 		001 260 8457	02.20483 
GM 710/717/718	<ul style="list-style-type: none"> EN Valve DE Ventil FR Soupape ES Válvula PT Válvula RU Клапан 		0750 132 033	02.23188 

THE ORIGINAL NUMBERS OF THE VEHICLE MANUFACTURER MAY BE USED FOR COMPARISON PURPOSES ONLY AND MUST NOT BE MENTIONED ON INVOICES TO VEHICLE OWNERS.

Application	Description	Details	Ref.	Erqo No.
NG/MK/SK	<ul style="list-style-type: none"> EN Valve, with nut DE Ventil, mit Mutter FR Soupape, avec écrou ES Válvula, con tuerca PT Válvula, com parafuso RU Клапан, с гайкой 			02.22611
				
				
NG/MK/SK	<ul style="list-style-type: none"> EN Valve DE Ventil FR Soupape ES Válvula PT Válvula RU Клапан 	repl. Wabco 463 036 013 0	001 997 6136	02.22611
				
				
NG/MK/SK	<ul style="list-style-type: none"> EN Lock nut DE Kontermutter FR Ecrou ES Contratuerca PT Porca trava RU Контргайка 	M 28 x 1,5	383 990 0051	02.22474
				
				
BM 371/398	<ul style="list-style-type: none"> EN Vibration damper DE Vibrationsdämpfer FR Dampfer ES Amortiguador PT Amortecedor RU Виброгаситель 		000 268 0014	02.20644
				
				
BM 371/398	<ul style="list-style-type: none"> EN Lever DE Hebel FR Levier ES Palanca PT Garfo embreagem RU Рычаг 		387 268 0030	02.20650
				
				

THE ORIGINAL NUMBERS OF THE VEHICLE MANUFACTURER MAY BE USED FOR COMPARISON PURPOSES ONLY AND MUST NOT BE MENTIONED ON INVOICES TO VEHICLE OWNERS.

Application	Description	Details	Ref.	Erqo No.
BM 621, 624/625, 646, 649, 655/656, 659	<ul style="list-style-type: none"> EN Rubber bearing DE Gummilager FR Silentbloc ES Cojinete de goma PT Coxim RU Резиновая подушка 		621 285 0003	02.20708 
BM 625, 655/656, 659	<ul style="list-style-type: none"> EN Rubber buffer air filter DE Gummipuffer Luftfilter FR Silentbloc filtre à air ES Tope de goma filtro aire PT Coxim filtro ar RU Сайлентблок воздушного фильтра 		001 987 7140	02.22408 
BM 381/383/385/398, 615.224/226, 616/617, 621/624	<ul style="list-style-type: none"> EN Valve DE Ventil FR Soupape ES Válvula PT Válvula RU Клапан 	repl. Wabco 463 037 001 0 	001 997 9136	02.22612 

Clutch & Brake Pedal



Kupplungs- & Bremspedal • Pédales, Embrayage & Freinage • Pedal de Embrague & Freno
Embreagem & Pedal de Freio • Педаль сцепления и тормоза

2







Application	Description	Details	Ref.	Erqo No.
BM 381/383/385/387, 389/391/393, BM 617/619/620/621, 622/623/624/645, 646/647	<ul style="list-style-type: none"> EN Pedal rubber DE Pedalgummi FR Caoutchouc de pédale ES Goma del pedal PT Borracha pedal freio RU Обрезиненная площадка педали 		107 291 0182	02.20738 

BM 625/652/653/655, 656/658/959	<ul style="list-style-type: none"> EN Pedal rubber DE Pedalgummi FR Caoutchouc de pédale ES Goma del pedal PT Borracha pedal freio RU Обрезиненная площадка педали 		201 292 0082	02.20741 
---------------------------------------	--	---	--------------	---





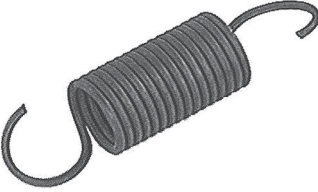



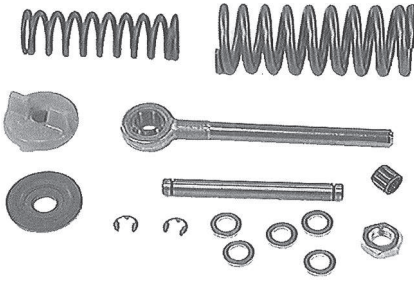

BM 625/652/653/655, 656/658/959	<ul style="list-style-type: none"> EN Pedal rubber DE Pedalgummi FR Caoutchouc de pédale ES Goma del pedal PT Borracha pedal freio RU Обрезиненная площадка педали 		201 291 0282	02.20740 
---------------------------------------	--	--	--------------	---

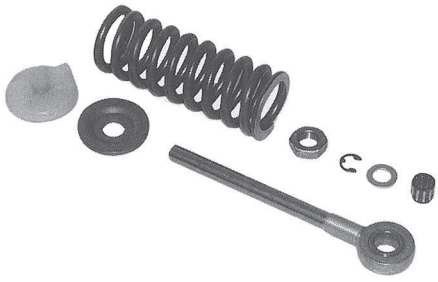



BM 381/383/385/ 389/391/393, BM 616/617/619/620/ 621/622/623/624/625	<ul style="list-style-type: none"> EN Return spring clutch pedal DE Rückholfeder Kupplungspedal FR Ressort de mâchoire pédale d'embrayage ES Muelle de retorno pedal de embrague PT Mola retorno pedal embraiagem RU Пружина Педаль сцепления 		381 993 0710	02.22549 
--	---	--	--------------	---

THE ORIGINAL NUMBERS OF THE VEHICLE MANUFACTURER MAY BE USED FOR COMPARISON PURPOSES ONLY AND MUST NOT BE MENTIONED ON INVOICES TO VEHICLE OWNERS.

Application	Description	Details	Ref.	Erqo No.
BM 620/621/622/623/ 624/625, BM 645/646/647/ 648/649	<ul style="list-style-type: none"> EN Return spring clutch pedal DE Rückholfeder Kupplungspedal FR Ressort de mâchoire pédale d'embrayage ES Muelle de retorno pedal del embrague PT Mola retorno pedal embraiagem RU Пружина Педаль сцепления 		620 993 0010	02.22555 
				
BM 381/383/385/387/ 389/393/395, BM 620/621/622/623	<ul style="list-style-type: none"> EN Return spring brake pedal DE Rückholfeder Bremspedal FR Ressort de mâchoire pédale de frein ES Muelle de retorno pedal de freno PT Mola retorno pedal travão RU Пружина педали тормоза 		381 993 0210	02.22548 
				
BM 616/617/619, BM 620/621/622/623/ 624/625, BM 645/646/647/ 648/649	<ul style="list-style-type: none"> EN Return spring brake pedal DE Rückholfeder Bremspedal FR Ressort de mâchoire pédale de frein ES Muelle de retorno pedal de freno PT Mola retorno pedal travão RU Пружина Педаль тормоза 		387 993 5010	02.22550 
				
BM 652/653/654/655/ 656/657/658/659	<ul style="list-style-type: none"> EN Return spring DE Rückholfeder FR Ressort de mâchoire ES Muelle de retorno PT Mola retorno RU Возвратная пружина 		655 993 0010	02.22556 
				

THE ORIGINAL NUMBERS OF THE VEHICLE MANUFACTURER MAY BE USED FOR COMPARISON PURPOSES ONLY AND MUST NOT BE MENTIONED ON INVOICES TO VEHICLE OWNERS.

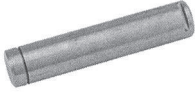
Application	Description	Details	Ref.	Erqo No.
BM 380/3817383/385, 387/389, 393/395, 615/616/617/619 --240 PS	<ul style="list-style-type: none"> EN Repair kit DE Reparatursatz FR Kit de réparation ES Kit de reparación PT Jogo reparo RU Ремонтный комплект 		380 290 0193	02.20734 
BM 385/387/389, 391/393/395/398 615/616/617, 620/621/622/623, 624/625	<ul style="list-style-type: none"> EN Repair kit DE Reparatursatz FR Kit de réparation ES Kit de reparación PT Jogo reparo RU Ремонтный комплект 		380 290 0293	02.20735 
BM 381/383/385/387/389/ 393/395/397 BM 616/617/620/622/ 623/624	<ul style="list-style-type: none"> EN Ball joint DE Kugelgelenk FR Rotule ES Rótula PT Articulação alavanca RU Шариковый шарнир 		381 291 0333 S	02.23189 
BM 381/383/385/387/389, 393,395/397 BM 616/617/620/622, 623/624	<ul style="list-style-type: none"> EN Joint bearing DE Gelenklager FR Palier articulé ES Cojinete articulado PT Haste RU Подшипник 		381 291 0333	02.20737 
BM 380/381/383/385, 387/389/391/393, 395/398 BM 615/616/617/619, 620/621/622/623, 624/625	<ul style="list-style-type: none"> EN Needle cage DE Nadelkäfig FR Roulement à aiguilles ES Portaaguja PT Rolamento agulha RU Сепаратор игольч. подшипника 	8 x 11 x 10	005 981 4410	02.22364  

Application	Description	Details	Ref.	Erqo No.
BM 381/383/385/387/389, 393/395 BM 616/617/619/620, 621/622/623/624/625, 645/646/647/648/649	EN Bearing bolt kit DE Lagerzapfensatz FR Kit de Palier Tourillon ES Kit de Gorrón PT Jogo Parafuso RU Коренная шейка комплект		011 981 3410 S	02.23190 
BM 381/383/385/387, 389/393/395 BM 616/617/619/620, 621/622/623/624, 625, 645/646/647/648, 649	EN Bearing bolt DE Lagerzapfen FR PalierTourillon ES Gorrón PT Parafuso RU Коренная шейка		381 294 0707	02.20742 
BM 381/383/385/387, 389/393/395 BM 616/617/619/620, 621/622/623/624, 625, 645/646/647/648, 649	EN Needle bearing DE Nadellager FR Roulement à aiguilles ES Cojinete agujas PT Rolamento agulha RU Игольчатый подшипник	repl. INA HK 2016	011 981 3410	02.22381 





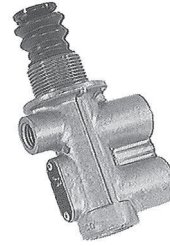



Application	Description	Details	Ref.	Erqo No.
BM 380/381/383/385, 387/389, 393/395, 620/621/624	<ul style="list-style-type: none"> EN Cylinder DE Zylinder FR Cylindre ES Cilindro PT Cilindro RU Рабочий цилиндр сцепления 		000 295 8706	02.20743 
BM 371/625	<ul style="list-style-type: none"> EN Master cylinder DE Geberzylinder FR Cylindre impulseur ES Cilindro maestro PT Cilindro mestre RU Главный цилиндр 		001 295 7106	02.20747 
BM 381/383/385/387, 389/391/395, BM 620/621/623/623	<ul style="list-style-type: none"> EN Stop light switch DE Bremslichtschalter FR Contacteur de stop ES Interruptor de luz de freno PT Interruptor, luz freio RU Выключатель сигнала 		000 545 5509	02.21966 
BM 380/381/383/385, 387/389, 393/395, 620/621/624	<ul style="list-style-type: none"> EN Repair kit DE Reparatursatz FR Kit de réparation ES Kit de reparación PT Jogo reparo RU Ремонтный комплект 		000 586 4729	02.22074 
NG/MK/SK	<ul style="list-style-type: none"> EN Fork joint DE Gabelkopf FR Tête de fourche ES Cabeza de horquilla PT Garfo haste RU Головка вилки 	M 8	620 996 0001	02.22569 
Unimog	<ul style="list-style-type: none"> EN Gasket kit, cylinder DE Dichtsatz, Zylinder FR Kit de joints, cylindre ES Juego de juntas, Cilindro PT Jogo junta, cilindro RU Комплект уплотнителей 		000 290 2512	02.20714 





Application	Description	Details	Ref.	Erqo No.
BM 620/621/623/624, 625, 645/646/648/649, 652/653/654/655, 656/657/658/659	EN Control valve DE Kontrollventil FR Soupape de contrôle ES Válvula de control PT Válvula controle da válvula split RU Контрольный клапан		000 434 3801	02.21525 



Application	Description	Details	Ref.	Erqo No.
NG/MK/SK	<ul style="list-style-type: none"> EN Hose line DE Schlauchleitung FR Durite droite ES Tubo flexible PT Flexível RU Шлангопровод 	L: 215 mm	000 295 1735	02.20762 
NG/MK/SK	<ul style="list-style-type: none"> EN Hose line DE Schlauchleitung FR Durite droite ES Tubo flexible PT Flexível RU Шлангопровод 	L: 350 mm	000 295 1835	02.20763 
NG/MK/SK	<ul style="list-style-type: none"> EN Hose line DE Schlauchleitung FR Durite droite ES Tubo flexible PT Flexível RU Шлангопровод 	L: 300 mm	000 295 2435	02.20764 
NG/MK/SK	<ul style="list-style-type: none"> EN Hose line DE Schlauchleitung FR Durite droite ES Tubería flexible PT Mangueira RU Трубопровод 	L: 1100 mm	381 290 2014	02.20723 
NG/MK/SK	<ul style="list-style-type: none"> EN Hose line DE Schlauchleitung FR Durite droite ES Tubería flexible PT Mangueira RU Трубопровод 	L: 1500 mm	381 290 2114	02.20724 

THE ORIGINAL NUMBERS OF THE VEHICLE MANUFACTURER MAY BE USED FOR COMPARISON PURPOSES ONLY AND MUST NOT BE MENTIONED ON INVOICES TO VEHICLE OWNERS.

Application	Description	Details	Ref.	Erqo No.
NG/MK/SK	<ul style="list-style-type: none"> EN Hose line DE Schlauchleitung FR Durite droite ES Tubería PT Mangueira RU Трубопровод 	L: 700 mm	381 290 1814	02.20721 
				
NG/MK/SK	<ul style="list-style-type: none"> EN Hose line DE Schlauchleitung FR Durite droite ES Tubería PT Mangueira RU Трубопровод 	L: 550 mm	381 290 1614	02.20720 
				
NG/MK/SK	<ul style="list-style-type: none"> EN Hose line DE Schlauchleitung FR Durite droite ES Tubería flexible PT Mangueira RU Трубопровод 	L: 800 mm	381 290 1914	02.20722 
				
NG/MK/SK	<ul style="list-style-type: none"> EN Hose line DE Schlauchleitung FR Durite droite ES Tubería flexible PT Flexível RU Шлангопровод 	L: 605 mm	398 295 0035	02.20765 
				

Application	Description	Details	Ref.	Erqo No.
BM 625, 652/653/654/ 655/656/658/659	<ul style="list-style-type: none"> EN Hose line DE Schlauchleitung FR Durite droite ES Tubo flexible PT Flexível RU Шлангопровод 	L: 1750 mm	655 290 3013	02.20716 
BM 625, 655/656/657/658/659	<ul style="list-style-type: none"> EN Hose line DE Schlauchleitung FR Durite droite ES Tubo flexible PT Flexível RU Шлангопровод 	L: 1680 mm	655 290 4413	02.20719 
BM 625, 652/653/654/ 655/656/657/658/659	<ul style="list-style-type: none"> EN Hose line DE Schlauchleitung FR Durite droite ES Tubería flexible PT Flexível RU Шлангопровод 	L: 1630 mm	655 290 4013	02.20718 
NG/MK/SK	<ul style="list-style-type: none"> EN Hose line DE Schlauchleitung FR Durite droite ES Tubo flexible PT Flexível RU Шлангопровод 	L: 555 mm	000 295 1435	02.20761 

THE ORIGINAL NUMBERS OF THE VEHICLE MANUFACTURER MAY BE USED FOR COMPARISON PURPOSES ONLY AND MUST NOT BE MENTIONED ON INVOICES TO VEHICLE OWNERS.

HosesSchläuche • Туауах • Manguitos
Mangueiras • патрубкн

Application	Description	Details	Ref.	Erqo No.
NG/MK/SK	EN Hose DE Schlauch FR Туауах ES Latiguillo PT Mangueira RU Шланг	9 x 16 mm, in lengths of 25 m	000 997 8952	02.22740 



Accelerator Pedal

Gaspedal • Pédale accélérateur • Pedal acelerador
Pedal acelerador • педаль акселератора

2

Application	Description	Details	Ref.	Erqo No.
BM 380/381/383/385, 387/393, BM 616/617/619/620, 621/623/925/650, 651/652/653/655, 656/658	<ul style="list-style-type: none"> EN Repair kit, pedal DE Reparatursatz, Pedal FR Kit de réparation, Pédale ES Kit de reparación, Pedal PT Jogo reparo, pedal RU Ремонтный комплект, Педаль 		624 300 0304	02.20774 
BM 380/381/383/385, 387/393, BM 616/617/619/620, 621/623/625/650, 651/652/653/655, 656/658	<ul style="list-style-type: none"> EN Pedal DE Pedal FR Pédale ES Pedal PT Pedal RU Педаль 		615 300 0104	02.20772 
625, 651/652/653, 654/655/656/659 A/AK	<ul style="list-style-type: none"> EN Rod DE Stange FR Tige ES Barra PT Haste RU Штанга 		355 070 0475	02.19830 
BM 380/381/383/385, 387/393, BM 616/617/619/620, 621/623/625/650, 651/652/653/655, 656/658	<ul style="list-style-type: none"> EN Lever DE Hebel FR Levier ES Palanca PT Garfo embreagem RU Рычаг 		620 300 0628	02.20778 
BM 620/621/622/623, 624/645/646/647, 648/649/655/656, 658/659	<ul style="list-style-type: none"> EN Lever DE Hebel FR Levier ES Palanca PT Garfo embreagem RU Рычаг 		620 300 1128	02.20779 

THE ORIGINAL NUMBERS OF THE VEHICLE MANUFACTURER MAY BE USED FOR COMPARISON PURPOSES ONLY AND MUST NOT BE MENTIONED ON INVOICES TO VEHICLE OWNERS.

Accelerator Pedal

Gaspedal • Pédale accélérateur • Pedal acelerador
Pedal acelerador • педаль акселератора

Application	Description	Details	Ref.	Erqo No.
BM 380/381/383/385, 387/393, BM 616/617/619/620, 621/623/625/650, 651/652/653/655, 656/658	EN Plastic bushing DE Kunststoffbuchse FR Douille plastique ES Cásquillo de plástico PT Bucha plástica RU Пластиковая втулка		381 302 0050	02.20791 
BM 380/381/383/385/ 387/393 BM 616/617/619, 620/621/623, 625, 650/651/652/653/655, 656/658	EN Ball pinion DE Kugelzapfen FR Tourillon à bille ES Perno esférico PT Pivô RU Сферическая цапфа	M 6 / Ø 10 mm 	312 991 0120	02.22517 
BM 380/381/383/385/ 387/393 BM 616/617/619, BM 620/621/623, 625, 650/651/652/653/655, 656/658	EN Ball pivot DE Kugelzapfen FR Tourillon à bille ES Perno esférico PT Pivô RU Сферическая цапфа	M 5 / Ø 13mm 	071803 013208	02.22901 
BM 381/383/385/389, 391/393/395, 617/620/621/622, 623/624	EN Wire right DE Drahtzug rechts FR Câble droit ES Cable de acelerador derecho PT Cabo direito RU Проволочная тяга правый	L: 1530 mm 	381 300 1430	02.20780 
BM 387/389/391/393, 395, 620/621/622/623, 624	EN Wire left DE Drahtzug links FR Câble gauche ES Cable de acelerador izquierdo PT Cabo esquerdo RU Проволочная тяга левый	L: 1330 mm 	381 300 1730	02.20781 

THE ORIGINAL NUMBERS OF THE VEHICLE MANUFACTURER MAY BE USED FOR COMPARISON PURPOSES ONLY AND MUST NOT BE MENTIONED ON INVOICES TO VEHICLE OWNERS.

Accelerator Pedal

Gaspedal • Pédale accélérateur • Pedal acelerador
Pedal acelerador • педаль акселератора

2

Application	Description	Details	Ref.	Erqo No.
BM 615/616/617/619, 620/621/622/623, 624/625, 645/646/647/648, 649	<ul style="list-style-type: none"> EN Wire new Version DE Drahtzug neue Ausführung FR Câble nouvelle version ES Cable de acelerador nueva versión PT Cabo nova versão RU Проволочная тяга нового типа 	L: 2150 mm	620 300 0130	02.20782 



BM 625/655/656, 657/658/659	<ul style="list-style-type: none"> EN Wire DE Drahtzug FR Câble ES Cable de acelerador PT Cabo RU Проволочная тяга 	L: 2675 mm	655 300 0630	02.20785 
-----------------------------------	--	------------	--------------	---

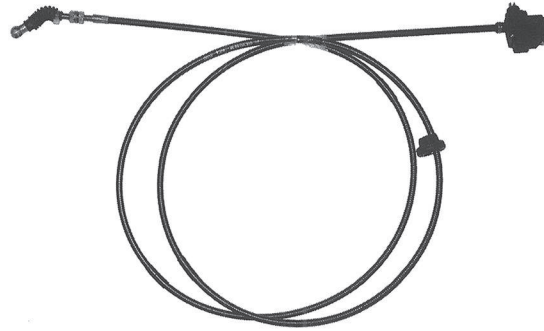









BM 655/656/657/658, 659 -- chassis 5418368	<ul style="list-style-type: none"> EN Wire DE Drahtzug FR Câble ES Cable de acelerador PT Cabo RU Проволочная тяга 	L: 2220 mm	655 300 0430	02.20783 
---	--	------------	--------------	---

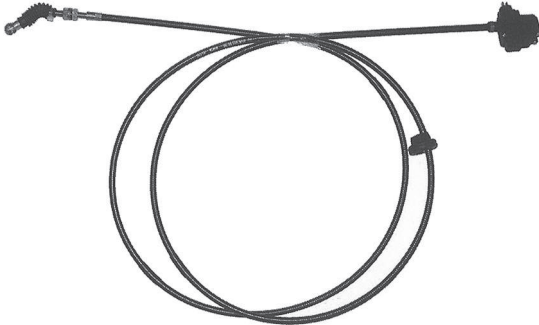

BM 652/653/654/655, 656/657/658/659	<ul style="list-style-type: none"> EN Wire DE Drahtzug FR Câble ES Cable de acelerador PT Cabo RU Проволочная тяга 		652 300 0032	02.20787 
---	--	--	--------------	---



Accelerator PedalGaspedal • Pédale accélérateur • Pedal acelerador
Pedal acelerador • педаль акселератора

Application	Description	Details	Ref.	Erqo No.
BM 625/655/656, 657/658/659	<ul style="list-style-type: none"> EN Wire DE Drahtzug FR Câble ES Cable de acelerador PT Cabo RU Проволочная тяга 		658 300 0032	02.20789 
BM 625/655/656/657, 658/659 -- chassis 5966518	<ul style="list-style-type: none"> EN Wire DE Drahtzug FR Câble ES Cable de acelerador PT Cabo RU Проволочная тяга 	L: 2280 mm 	655 300 0730	02.20786 
BM 652/653/654/655, 656/657/658/659 chassis --	<ul style="list-style-type: none"> EN Wire DE Drahtzug FR Câble ES Cable de acelerador PT Cabo RU Проволочная тяга 	L: 2670 mm 	655 300 0032	02.20788 
BM 655/656/657/658, 659	<ul style="list-style-type: none"> EN Wire DE Drahtzug FR Câble ES Cable de acelerador PT Cabo RU Проволочная тяга 	L: 2180 mm 	655 300 0530	02.20784 

THE ORIGINAL NUMBERS OF THE VEHICLE MANUFACTURER MAY BE USED FOR COMPARISON PURPOSES ONLY AND MUST NOT BE MENTIONED ON INVOICES TO VEHICLE OWNERS.

Accelerator Pedal

Gaspedal • Pédale accélérateur • Pedal acelerador
Pedal acelerador • педаль акселератора

2

Application	Description	Details	Ref.	Erqo No.
BM 381/383/385/387, 389/391/393/395, 615/616/617/619, 620/621/622/623, 624/625/645/646, 647/648/649	<ul style="list-style-type: none"> EN Manual control DE Handregulierung FR Reglage manuel ES Ajustador manual PT Controle manual RU Устройство ручн. регулирования 		381 300 0326	02.20777 
BM 616/617/619, BM 620/621/622/623/ 624/625, BM 645/646/647/ 648/649, BM 652/653/654/655/ 656/657/658/659	<ul style="list-style-type: none"> EN Rod, pedal DE Stange, Fahrpedal FR Tige, Pédale de conduite ES Barra, Pedal acelerador PT Haste, pedal RU Штанга, Педаль акселератора 		620 300 0615	02.20775 
NG/MK/SK	<ul style="list-style-type: none"> EN Ball socket DE Kugelpfanne FR Rotule ES Rótula PT Terminal RU Шаровой подпятник 		406 991 0022	02.22524 
NG/MK/SK	<ul style="list-style-type: none"> EN Angle joint DE Winkelgelenk FR Joint à angle ES Rótula PT Terminal angular RU Угловой шарнир 	M 5 / AS 8 	02.23352 	
NG/MK/SK	<ul style="list-style-type: none"> EN Angle joint DE Winkelgelenk FR Joint à angle ES Rótula PT Terminal angular RU Угловой шарнир 	M 6 / AS 10 	02.23353 	
NG/MK/SK	<ul style="list-style-type: none"> EN Angle joint DE Winkelgelenk FR Joint à angle ES Rótula PT Terminal angular RU Угловой шарнир 	M 8 / AS13 	02.23354 	

THE ORIGINAL NUMBERS OF THE VEHICLE MANUFACTURER MAY BE USED FOR COMPARISON PURPOSES ONLY AND MUST NOT BE MENTIONED ON INVOICES TO VEHICLE OWNERS.













Accelerator PedalGaspedal • Pédale accélérateur • Pedal acelerador
Pedal acelerador • педаль акселератора

Application	Description	Details	Ref.	Erqo No.
NG/MK/SK	<ul style="list-style-type: none"> EN Angle joint DE Winkelgelenk FR Joint à angle ES Rótula PT Terminal angular RU Угловой шарнир 	M 10 / AS 16		02.23355 
NG/MK/SK	<ul style="list-style-type: none"> EN Angle joint DE Winkelgelenk FR Joint à angle ES Rótula PT Terminal angular RU Угловой шарнир 	M 12 / AS 16		02.23356 
NG/MK/SK	<ul style="list-style-type: none"> EN Angle joint DE Winkelgelenk FR Joint à angle ES Rótula PT Terminal angular RU Угловой шарнир 	M 14 x 1,5 / AS 19		02.23357 
NG/MK/SK	<ul style="list-style-type: none"> EN Ball pivot DE Kugelzapfen FR Tourillon à bille ES Perno esférico PT Pivô RU Сферическая цапфа 	M 5 / Ø 8 mm		02.23358 
NG/MK/SK	<ul style="list-style-type: none"> EN Ball pivot DE Kugelzapfen FR Tourillon à bille ES Perno esférico PT Pivô RU Сферическая цапфа 	M 6 / Ø 10 mm, LH		02.23359 
NG/MK/SK	<ul style="list-style-type: none"> EN Ball pivot DE Kugelzapfen FR Tourillon à bille ES Perno esférico PT Pivô RU Сферическая цапфа 	M 8 / Ø 13 mm		02.23360 

THE ORIGINAL NUMBERS OF THE VEHICLE MANUFACTURER MAY BE USED FOR COMPARISON PURPOSES ONLY AND MUST NOT BE MENTIONED ON INVOICES TO VEHICLE OWNERS.

Application	Description	Details	Ref.	Erqo No.
NG/MK/SK	(EN) Ball pivot (DE) Kugelzapfen (FR) Tourillon à bille (ES) Perno esférico (PT) Pivô (RU) Сферическая цапфа	M 10 / Ø 16 mm		02.23361 
NG/MK/SK	(EN) Ball pivot (DE) Kugelzapfen (FR) Tourillon à bille (ES) Perno esférico (PT) Pivô (RU) Сферическая цапфа	M 12 / Ø 16 mm		02.23362 
NG/MK/SK	(EN) Ball pivot (DE) Kugelzapfen (FR) Tourillon à bille (ES) Perno esférico (PT) Pivô (RU) Сферическая цапфа	M 14 / Ø 19 mm		02.23363 
NG/MK/SK	(EN) Ball socket (DE) Kugelpfanne (FR) Rotule (ES) Cazoleta esférica (PT) Terminal (RU) Шаровой подпятник	M 5 / Ø 8 mm		02.23364 
NG/MK/SK	(EN) Ball socket (DE) Kugelpfanne (FR) Rotule (ES) Cazoleta esférica (PT) Terminal (RU) Шаровой подпятник	M 6 / Ø 10 mm, RH		02.23365 
NG/MK/SK	(EN) Ball socket (DE) Kugelpfanne (FR) Rotule (ES) Cazoleta esférica (PT) Terminal (RU) Шаровой подпятник	M 8 / Ø 13 mm		02.23366 

Accelerator PedalGaspedal • Pédale accélérateur • Pedal acelerador
Pedal acelerador • педаль акселератора

Application	Description	Details	Ref.	Erqo No.
NG/MK/SK	<ul style="list-style-type: none"> EN Ball socket DE Kugelpfanne FR Rotule ES Cazoleta esférica PT Terminal RU Шаровой подпятник 	M 10 / Ø 16 mm		02.23367 
NG/MK/SK	<ul style="list-style-type: none"> EN Ball socket DE Kugelpfanne FR Rotule ES Cazoleta esférica PT Terminal RU Шаровой подпятник 	M 12 / Ø 16mm		02.23368 
NG/MK/SK	<ul style="list-style-type: none"> EN Ball socket DE Kugelpfanne FR Rotule ES Cazoleta esférica PT Terminal RU Шаровой подпятник 	M 14 / Ø 19 mm		02.23369 
NG/MK/SK	<ul style="list-style-type: none"> EN Circlip DE Sicherungsbügel FR Circlip ES Varilla de seguridad PT Clipe RU Предохранительная скоба 	S 8		02.23370 
NG/MK/SK	<ul style="list-style-type: none"> EN Circlip DE Sicherungsbügel FR Circlip ES Varilla de seguridad PT Clipe RU Предохранительная скоба 	S 10		02.23371 
NG/MK/SK	<ul style="list-style-type: none"> EN Circlip DE Sicherungsbügel FR Circlip ES Varilla de seguridad PT Clipe RU Предохранительная скоба 			02.23372 

THE ORIGINAL NUMBERS OF THE VEHICLE MANUFACTURER MAY BE USED FOR COMPARISON PURPOSES ONLY AND MUST NOT BE MENTIONED ON INVOICES TO VEHICLE OWNERS.

Accelerator Pedal

Gaspedal • Pédale accélérateur • Pedal acelerador
 Pedal acelerador • педаль акселератора

2

Application	Description	Details	Ref.	Erqo No.
NG/MK/SK	<ul style="list-style-type: none"> EN Circlip DE Sicherungsbügel FR Circlip ES Varilla de seguridad PT Clipe RU Предохранительная скоба 	S 16		02.23373



NG/MK/SK	<ul style="list-style-type: none"> EN Circlip DE Sicherungsbügel FR Circlip ES Varilla de seguridad PT Clipe RU Предохранительная скоба 	S 19		02.23374
----------	---	------	--	----------



Spring BracketFederhalter • Ressort de Support • Soporte Ballesta
Suporte mola • Кронштейн рессоры

Application	Description	Details	Ref.	Erqo No.
NG/MK/SK	<ul style="list-style-type: none"> EN Helper spring bracket DE Zusatzfederbock FR Ressort suppl. ES Soporte de Ballesta Auxiliar PT Suporte feixe mola RU Кронштейн рессоры 		684 325 0017	02.20908 
MK/SK --chassis K062674	<ul style="list-style-type: none"> EN Spring bracket front axle DE Federhalter Vorderachse FR Support de ressort essieu avant ES Soporte de Ballesta eje delantero PT Suporte feixe mola eixo frente RU Кронштейн рессоры передней оси 		620 322 0901	02.20842 
MK/SK	<ul style="list-style-type: none"> EN Spring bracket 2. front axle DE Federhalter 2. Vorderachse FR Support de ressort 2ème essieu avant ES Soporte de Ballesta 2º eje delantero PT Suporte feixe mola 2º eixo da frente RU Кронштейн рессоры 2-й передней оси 		620 322 0103	02.20843 
MK/SK	<ul style="list-style-type: none"> EN Spring bracket rear axle DE Federhalter Hinterachse FR Support de ressort essieu arrière ES Soporte de Ballesta eje trasero PT Suporte feixe mola eixo trazeiro RU Кронштейн рессоры задней оси 		387 325 0001	02.20898 

THE ORIGINAL NUMBERS OF THE VEHICLE MANUFACTURER MAY BE USED FOR COMPARISON PURPOSES ONLY AND MUST NOT BE MENTIONED ON INVOICES TO VEHICLE OWNERS.

Application	Description	Details	Ref.	Erqo No.
NG/MK/SK	<ul style="list-style-type: none"> EN Spring bracket 2. rear axle DE Federhalter 2. Hinterachse FR Support de ressort 2ème essieu arrière ES Soporte de Ballesta 2o eje trasero PT Suporte feixe mola 2o eixo traseiro RU Кронштейн рессоры 2. задней оси 		335 325 0603	02.20899 
MK/SK	<ul style="list-style-type: none"> EN Spring bracket, left 2. rear axle DE Federhalter, links 2. Hinterachse FR Axe de ressort, gauche 2ème essieu arrière ES Soporte de ballesta, izquierdo 2º eje trasero PT Suporte feixe mola, esquerdo 2o eje traseiro RU Кронштейн рессоры, лев. 2. задней оси 		621 325 0003	02.20900 
MK/SK	<ul style="list-style-type: none"> EN Spring bracket, right 2. rear axle DE Federhalter, rechts 2. Hinterachse FR Axe de ressort, droit 2ème essieu arrière ES Soporte de ballesta, derecho 2º eje trasero PT Suporte feixe mola, direito 2o eje traseiro RU Кронштейн рессоры, прав. 2. задней оси 		621 325 0004	02.20901 
BM 393/395, 623/624/625, 648/649, 658/659	<ul style="list-style-type: none"> EN Rubber mounting rear axle DE Gummilager Hinterachse FR Silentbloc essieu arrière ES Tope de goma eje trasero PT Coxim eixo trazeiro RU Резиновая подушка задней оси 		393 325 0044	02.20925 

Sample



THE ORIGINAL NUMBERS OF THE VEHICLE MANUFACTURER MAY BE USED FOR COMPARISON PURPOSES ONLY AND MUST NOT BE MENTIONED ON INVOICES TO VEHICLE OWNERS.

Application	Description	Details	Ref.	Erqo No.
BM 393/395/398, 623/624/625, 648, 658/659	EN Support DE Träger FR Support ES Soporte PT Suporte RU Кронштейн		624 325 0310	02.20903 
				
NG/MK/SK	EN Bolt with safety nut DE Bolzen mit Mutter FR Jeu d'axes ES Perno con tuerca PT Parafuso com porca RU Болт с гайкой	M 16 x 40	346 990 0014	02.22463 
				
NG/MK/SK	EN Bolt with nut DE Bolzen mit Mutter FR Jeu d'axes ES Perno con tuerca PT Parafuso com porca RU Болт с гайкой	M 16 x 1,5 x 50	346 990 0114	02.22464 
				
NG/MK/SK	EN Bolt DE Bolzen FR Axe ES Bulón PT Parafuso RU Болт	M 16 x 48	000 990 6314	02.22462 
				
NG/MK/SK	EN Bolt with safety nut DE Bolzen mit Mutter FR Jeu d'axes ES Perno con tuerca PT Parafuso com porca RU Болт с гайкой	M 12 x 1,5	002 990 8201	02.22413 
				
NG/MK/SK	EN Screw DE Schraube FR Vis ES Tornillo PT Parafuso RU Болт	M 8 x 40	000931 008266	02.22820 
				

THE ORIGINAL NUMBERS OF THE VEHICLE MANUFACTURER MAY BE USED FOR COMPARISON PURPOSES ONLY AND MUST NOT BE MENTIONED ON INVOICES TO VEHICLE OWNERS.

Application	Description	Details	Ref.	Erqo No.
NG/MK/SK	<ul style="list-style-type: none"> EN Screw DE Schraube FR Vis ES Tornillo PT Parafuso RU Болт 	M 8 x 75	000 990 5304	02.22435 
				
NG/MK/SK	<ul style="list-style-type: none"> EN Screw DE Schraube FR Vis ES Tornillo PT Parafuso RU Болт 	M 12 x 50	000931 012132	02.22822 
				
NG/MK/SK	<ul style="list-style-type: none"> EN Screw DE Schraube FR Vis ES Tornillo PT Parafuso RU Болт 	M 12 x 30	304017 012020	02.22938 
				
NG/MK/SK	<ul style="list-style-type: none"> EN Bolt DE Bolzen FR Boulon ES Perno PT Parafuso RU Болт 	M 12 x 1,5 x 55	000960 012384	02.22832 
				
NG/MK/SK	<ul style="list-style-type: none"> EN Screw DE Schraube FR Vis ES Tornillo PT Parafuso RU Болт 	M 16 x 1,5 x 80	000960 016105	02.22833 
				
NG/MK/SK	<ul style="list-style-type: none"> EN Screw DE Schraube FR Vis ES Tornillo PT Parafuso RU Болт 	M 16 x 1,5 x 85	000960 016164	02.22834 
				

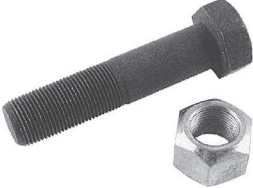
THE ORIGINAL NUMBERS OF THE VEHICLE MANUFACTURER MAY BE USED FOR COMPARISON PURPOSES ONLY AND MUST NOT BE MENTIONED ON INVOICES TO VEHICLE OWNERS.

Application	Description	Details	Ref.	Erqo No.
NG/MK/SK	<ul style="list-style-type: none"> EN Screw DE Schraube FR Vis ES Tornillo PT Parafuso RU Болт 	M 18 x 1,5 x 160	000000 000643	02.22799 
				
NG/MK/SK	<ul style="list-style-type: none"> EN Screw DE Schraube FR Vis ES Tornillo PT Parafuso RU Болт 	M 18 x 1,5 x 205	343 990 0101	02.22417 
				
NG/MK/SK	<ul style="list-style-type: none"> EN Screw DE Schraube FR Vis ES Tornillo PT Parafuso RU Болт 	M 20 x 1,5 x 90	308765 020012	02.22947 
				
NG/MK/SK	<ul style="list-style-type: none"> EN Screw with nut DE Schraube mit Mutter FR Vis avec écrou ES Tornillo con tuerca PT Parafuso com porca RU Болт с гайкой 	M 20 x 1,5 x 90	308765 020012 S	02.23191 
				
NG/MK/SK	<ul style="list-style-type: none"> EN Screw DE Schraube FR Vis ES Tornillo PT Parafuso RU Болт 	M 18 x 1,5 x 80	000960 018145	02.22837 
				
NG/MK/SK	<ul style="list-style-type: none"> EN Screw with nut DE Schraube mit Mutter FR Vis avec écrou ES Tornillo con tuerca PT Parafuso com porca RU Болт с гайкой 	M 18 x 1,5 x 80	000960 018145 S	02.23192 
				

THE ORIGINAL NUMBERS OF THE VEHICLE MANUFACTURER MAY BE USED FOR COMPARISON PURPOSES ONLY AND MUST NOT BE MENTIONED ON INVOICES TO VEHICLE OWNERS.













Application	Description	Details	Ref.	Erqo No.
NG/MK/SK	EN Screw DE Schraube FR Vis ES Tornillo PT Parafuso RU Болт	M 16 x 1,5 x 60	000960 016171	02.22835 
				
NG/MK/SK	EN Screw with nut DE Schraube mit Mutter FR Vis avec écrou ES Tornillo con tuerca PT Parafuso com porca RU Болт с гайкой	M 16 x 1,5 x 60	000960 016171 S	02.23193 
				
NG/MK/SK	EN Screw DE Schraube FR Vis ES Tornillo PT Parafuso RU Болт	M 20 x 1,5 x 120	000960 020084	02.22840 
				
NG/MK/SK	EN Screw DE Schraube FR Vis ES Tornillo PT Parafuso RU Болт	M 20 x 1,5 x 140	308765 020010	02.22946 
				
NG/MK/SK	EN Screw DE Schraube FR Vis ES Tornillo PT Parafuso RU Болт	M 20 x 1,5 x 205	659 990 0001	02.22432 
				
NG/MK/SK	EN Screw DE Schraube FR Vis ES Tornillo PT Parafuso RU Болт	M 20 x 1,5 x 230	000960 020120	02.22841 
				

Application	Description	Details	Ref.	Erqo No.
NG/MK/SK	<ul style="list-style-type: none"> EN Screw DE Schraube FR Vis ES Tornillo PT Parafuso RU Болт 	M 20 x 1,5 x 240	308765 020016	02.22948 
				
NG/MK/SK	<ul style="list-style-type: none"> EN Bolt DE Bolzen FR Boulon ES Perno PT Parafuso RU Болт 	M 22 x 1,5 x 75	000960 022036	02.22842 
				
NG/MK/SK	<ul style="list-style-type: none"> EN Screw DE Schraube FR Vis ES Tornillo PT Parafuso RU Болт 	M 30 x 2 x 95	000960 030017	02.22843 
				
NG/MK/SK	<ul style="list-style-type: none"> EN Screw DE Schraube FR Vis ES Tornillo PT Parafuso RU Болт 	M 12 x 1,5 x 20	308676 012038	02.22944 
				
NG/MK/SK	<ul style="list-style-type: none"> EN Screw DE Schraube FR Vis ES Tornillo PT Parafuso RU Болт 	M 12 x 1,5 x 30	000961 012151	02.22847 
				
NG/MK/SK	<ul style="list-style-type: none"> EN Screw DE Schraube FR Vis ES Tornillo PT Parafuso RU Болт 	M 12 x 1,5 x 35	308676 012014	02.22942 
				

THE ORIGINAL NUMBERS OF THE VEHICLE MANUFACTURER MAY BE USED FOR COMPARISON PURPOSES ONLY AND MUST NOT BE MENTIONED ON INVOICES TO VEHICLE OWNERS.

Application	Description	Details	Ref.	Erqo No.
NG/MK/SK	<ul style="list-style-type: none"> EN Screw DE Schraube FR Vis ES Tornillo PT Parafuso RU Болт 	M 14 x 1,5 x 40	000961 014028	02.22848 
				
NG/MK/SK	<ul style="list-style-type: none"> EN Screw DE Schraube FR Vis ES Tornillo PT Parafuso RU Болт 	M 14 x 1,5 x 30	000961 014100	02.22850 
				
NG/MK/SK	<ul style="list-style-type: none"> EN Screw DE Schraube FR Vis ES Tornillo PT Parafuso RU Болт 	M 20 x 1,5 x 75	000 325 0775	02.20931 
				
NG/MK/SK	<ul style="list-style-type: none"> EN Nut DE Mutter FR Ecrou ES Tuercas PT Porca RU Гайка 	M 12		02.23375 
				
NG/MK/SK	<ul style="list-style-type: none"> EN Nut DE Mutter FR Ecrou ES Tuercas PT Porca RU Гайка 	M 12 x 1,5	000985 012005	02.22851 
				
NG/MK/SK	<ul style="list-style-type: none"> EN Nut DE Mutter FR Ecrou ES Tuercas PT Porca RU Гайка 	M 20 x 1,5		02.23376 
				

THE ORIGINAL NUMBERS OF THE VEHICLE MANUFACTURER MAY BE USED FOR COMPARISON PURPOSES ONLY AND MUST NOT BE MENTIONED ON INVOICES TO VEHICLE OWNERS.









Application	Description	Details	Ref.	Erqo No.
NG/MK/SK	EN Lock washer DE Federring FR Rondelle ES Anillo PT Trava eixo balancim RU Пружинное кольцо	Ø 10 mm	912004 010102	02.22956 
				
NG/MK/SK	EN Nut DE Mutter FR Ecrou ES Tuercas PT Porca RU Гайка	M 12 x 1,5		02.22939 
				
NG/MK/SK	EN Nut DE Mutter FR Ecrou ES Tuercas PT Porca RU Гайка	M 12	000934 012021	02.22827 
				
NG/MK/SK	EN Nut DE Mutter FR Ecrou ES Tuercas PT Porca RU Гайка	M 16 x 1,5	308673 016001	02.22939 
				
NG/MK/SK	EN Nut DE Mutter FR Ecrou ES Tuercas PT Porca RU Гайка	M 20 x 1,5	000934 020001	02.22830 
				
NG/MK/SK	EN Nut DE Mutter FR Ecrou ES Tuercas PT Porca RU Гайка	M 8	913004 008004	02.22957 
				

Spring Bracket





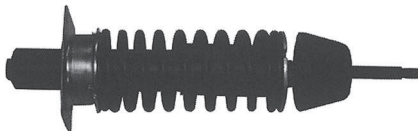

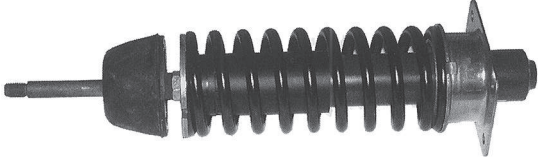

Federhalter • Ressort de Support • Soporte Ballesta
 Suporte mola • Кронштейн рессоры

Application	Description	Details	Ref.	Erqo No.
NG/MK/SK	<ul style="list-style-type: none"> EN Nut DE Mutter FR Ecrou ES Tuercas PT Porca RU Гайка 	M 14 x 1,5	913004 014001	02.22958 
				
NG/MK/SK	<ul style="list-style-type: none"> EN Nut DE Mutter FR Ecrou ES Tuercas PT Porca RU Гайка 	M 16 x 1,5	910113 016002	02.22954 
				
NG/MK/SK	<ul style="list-style-type: none"> EN Nut DE Mutter FR Ecrou ES Tuercas PT Porca RU Гайка 	M 20 x 1,5	913004 020003	02.22962 
				

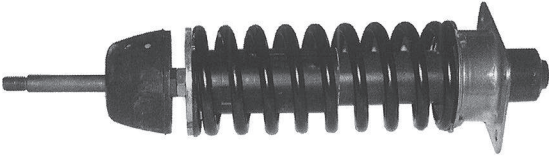





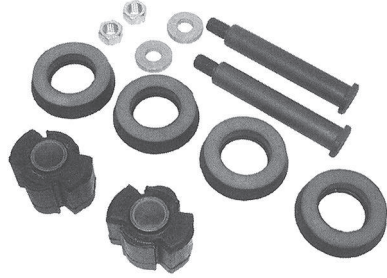

4

Application	Description	Details	Ref.	Erqo No.
NG	<ul style="list-style-type: none"> EN Cabin shock absorber DE Kabinenstoßdämpfer FR Amortisseur de cabine ES Amortiguador de la cabina PT Amortecedor RU Амортизатор кабины 		000 891 2005	02.22294 
Sample				
NG	<ul style="list-style-type: none"> EN Cabin shock absorber DE Kabinenstoßdämpfer FR Amortisseur de cabine ES Amortiguador de la cabina PT Amortecedor RU Амортизатор кабины 		000 891 1605	02.22292 
NG/MK/SK	<ul style="list-style-type: none"> EN Shock absorber DE Stoßdämpfer FR Amortisseur ES Amortiguador PT Amortecedor RU Амортизатор 		000 891 2205	02.22295 
NG/MK/SK	<ul style="list-style-type: none"> EN Shock absorber front DE Stoßdämpfer vorne FR Amortisseur avant ES Amortiguador de cabina delantero PT Amortecedor frente RU Амортизатор передняя 		387 890 1619	02.22286 





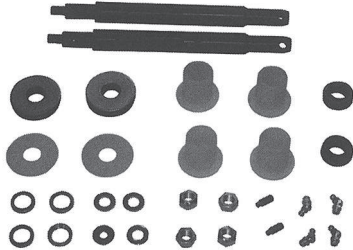

THE ORIGINAL NUMBERS OF THE VEHICLE MANUFACTURER MAY BE USED FOR COMPARISON PURPOSES ONLY AND MUST NOT BE MENTIONED ON INVOICES TO VEHICLE OWNERS.





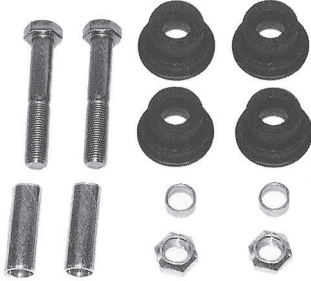



Application	Description	Details	Ref.	Erqo No.
MK/SK --chassis 5934199	<ul style="list-style-type: none"> EN Shock absorber rear DE Stoßdämpfer hinten FR Amortisseur arrière ES Amortiguador de cabina trasero PT Amortecedor trazeiro RU Амортизатор задняя 		620 890 0119	02.22288 
MK/SK chassis 5934200--	<ul style="list-style-type: none"> EN Shock absorber rear DE Stoßdämpfer hinten FR Amortisseur arrière ES Amortiguador de cabina trasero PT Amortecedor trazeiro RU Амортизатор задняя 		620 890 0319	02.22290 
BM 620/621/622/623, 624/625/645/646, 647/648/649/655, 656/657/658/659	<ul style="list-style-type: none"> EN Leaf spring DE Blattfeder FR Ressort à lame ES Hoja de ballesta PT Feixe molas RU Листовая рессора 		620 891 0151	02.22303 
BM 620/621/622/623, 624/625/645/646, 647/648/649/652, 655/656/657/658, 659	<ul style="list-style-type: none"> EN Leaf spring DE Blattfeder FR Ressort à lame ES Hoja de ballesta PT Feixe molas RU Листовая рессора 		620 891 0051	02.22302 



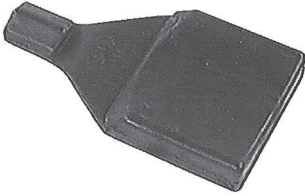



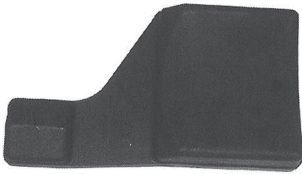

THE ORIGINAL NUMBERS OF THE VEHICLE MANUFACTURER MAY BE USED FOR COMPARISON PURPOSES ONLY AND MUST NOT BE MENTIONED ON INVOICES TO VEHICLE OWNERS.

Application	Description	Details	Ref.	Erqo No.
NG/MK/SK --chassis 5764324	<ul style="list-style-type: none"> EN Repair kit, cabin stabilizer DE Reparatursatz, Fahrerhausstabilisator FR Kit de réparation, stabilisateur cabine ES Kit de reparación, estabilizador de la cabina PT Jogo reparação, barra estabilizadora cabine RU Комплект подвески, Стабилизатор 		381 586 0031	02.22076 
NG/MK/SK	<ul style="list-style-type: none"> EN Repair kit, cabin stabilizer DE Reparatursatz, Fahrerhausstabilisator FR Kit de réparation, stabilisateur cabine ES Kit de reparación, estabilizador de la cabina PT Jogo reparação, barra estabilizadora cabine RU Комплект подвески, Стабилизатор 		620 586 0031	02.22079 
SK chassis 5764325--	<ul style="list-style-type: none"> EN Repair kit, cabin stabilizer DE Reparatursatz, Fahrerhausstabilisator FR Kit de réparation, stabilisateur cabine ES Kit de reparación, estabilizador de la cabina PT Jogo reparação, barra estabilizadora cabine RU Комплект подвески, Стабилизатор 		655 890 2903	02.22284 
NG/MK/SK	<ul style="list-style-type: none"> EN Repair kit, cabin stabilizer front DE Reparatursatz, Fahrerhausstabilisator vorne FR Kit de réparation, stabilisateur cabine avant ES Kit de reparación, estabilizador de la cabina delantero PT Jogo reparação, barra estabilizadora cabine frente RU Комплект подвески, Стабилизатор передняя 		387 310 0077	02.20793 

THE ORIGINAL NUMBERS OF THE VEHICLE MANUFACTURER MAY BE USED FOR COMPARISON PURPOSES ONLY AND MUST NOT BE MENTIONED ON INVOICES TO VEHICLE OWNERS.

Application	Description	Details	Ref.	Erqo No.
NG/MK --chassis 5178428	<ul style="list-style-type: none"> EN Repair kit, cabin stabilizer front DE Reparatursatz, Fahrerhausstabilisator vorne FR Kit de réparation, stabilisateur cabine avant ES Kit de reparación, estabilizador de la cabina delantero PT Jogo reparação, barra estabilizadora cabine frente RU Комплект подвески, Стабилизатор передняя 		387 586 0531	02.22078 
MK/SK chassis 5178429--	<ul style="list-style-type: none"> EN Repair kit, cabin stabilizer front DE Reparatursatz, Fahrerhausstabilisator vorne FR Kit de réparation, stabilisateur cabine avant ES Kit de reparación, estabilizador de la cabina delantero PT Jogo reparação, barra estabilizadora cabine frente RU Комплект подвески, Стабилизатор передняя 		620 310 0177	02.20795 
NG/MK/SK	<ul style="list-style-type: none"> EN Bushing tilt cylinder DE Buchse Kippzylinder FR Bague cylindre à bascule ES Casquillo cilindro basculante PT Bucha carteio cilindro RU Втулка опрокидывающий цилиндр 		620 891 0017	02.22298 

Application	Description	Details	Ref.	Erqo No.
NG/MK/SK	<ul style="list-style-type: none"> EN Rubber bearing rear DE Gummilager hinten FR Silentbloc arrière ES Cojinete de goma trasero PT Coxim trazeiro RU Резиновая подушка задняя 		387 891 0072	02.22307 
NG/MK/SK	<ul style="list-style-type: none"> EN Cab bearing rear DE Kabinenlager hinten FR Palier de cabine arrière ES Soporte de cabina trasero PT Suporte cabine trazeiro RU Резиновая подушка кабины задняя 		620 891 0272	02.22310 
NG/MK/SK	<ul style="list-style-type: none"> EN Cab bearing rear DE Kabinenlager hinten FR Palier de cabine arrière ES Soporte de cabina trasero PT Suporte cabine trazeiro RU Резиновая подушка кабины задняя 		620 891 0072	02.22308 
NG/MK/SK	<ul style="list-style-type: none"> EN Cab bearing rear DE Kabinenlager hinten FR Palier de cabine arrière ES Soporte de cabina trasero PT Suporte cabine trazeiro RU Резиновая подушка кабины задняя 		620 891 0172	02.22309 

Application	Description	Details	Ref.	Erqo No.
NG/MK/SK	<ul style="list-style-type: none"> EN Rubber buffer rear DE Gummipuffer hinten FR Silentbloc arrière ES Tope de goma trasero PT Coxim trazeiro RU Резиновый буфер задний 		387 891 0323	02.22301 
NG/MK/SK	<ul style="list-style-type: none"> EN Rubber bushing front DE Gummibuchse vorne FR Douille en caoutchouc avant ES Casquillo de goma delantero PT Coxim amortecedor frente RU Резиновая втулка передний 		334 891 0072	02.22306 
NG/MK/SK	<ul style="list-style-type: none"> EN Bushing DE Buchse FR Vague ES Casquillo PT Vucha RU Втулка 		363 891 0717	02.22296 
NG/MK/SK	<ul style="list-style-type: none"> EN Rubber buffer front DE Gummipuffer vorne FR Silentbloc avant ES Tope de goma delantero PT Coxim frente RU Резиновый буфер передний 		363 891 0223	02.22300 

THE ORIGINAL NUMBERS OF THE VEHICLE MANUFACTURER MAY BE USED FOR COMPARISON PURPOSES ONLY AND MUST NOT BE MENTIONED ON INVOICES TO VEHICLE OWNERS.

Application	Description	Details	Ref.	Erqo No.
BM 381/383/385/387, 391/393/395/615, 616/617/619/620, 621/622/623/624, 625/645/646/647, 648/649/652/655, 656/657/658/659	<p>EN Handle</p> <p>DE Griff</p> <p>FR Poignée</p> <p>ES Empuñadura</p> <p>PT Puxador bloqueio cabine</p> <p>RU Рукоятка</p>		620 891 0073	02.22313 







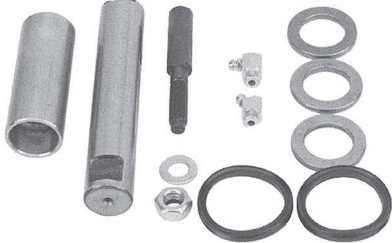

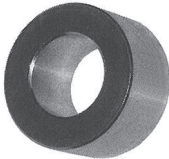

Application	Description	Details	Ref.	Erqo No.
BM 387/389/393, 620/621/623/624, 625, 645/646/647/648, 655/656/657/658, 659	<ul style="list-style-type: none"> EN Spring shackle DE Federschwinge FR Jumelle ES Gemela de ballesta PT Jumelo molejo RU Серьга рессоры 		387 320 0162	02.20821 
4 BM 380/381/383/385, 615/616/617/619	<ul style="list-style-type: none"> EN Spring shackle DE Federschwinge FR Jumelle ES Gemela de ballesta PT Jumelo molejo RU Серьга рессоры 		617 320 0163	02.20823 
BM 387/389 393/395, 620/621/623/624, 625, 645/647/648 655/656/657/658, 659	<ul style="list-style-type: none"> EN Spring bushing DE Federbuchse FR Bague de ressort ES Casquillo PT Bucha RU Втулка 	Ø 25 / 30 x 81 mm	304 321 0150	02.20838 
BM 380/381/383/384, 385, 615/616/617/619, 625	<ul style="list-style-type: none"> EN Spring bushing DE Federbuchse FR Bague de ressort ES Casquillo PT Bucha RU Втулка 	Ø 25 / 30 x 67 mm	385 322 0050	02.20844 
BM 380/381/383/385, 615/616/617/619	<ul style="list-style-type: none"> EN Spring bolt kit DE Federbolzensatz FR Jeu d'axes ES Juego de pernos de muelle PT Jogo reparo parafuso RU Комплект пальцев ушка рессоры 	Ø 25 x 126	385 320 0165	02.20825 
				

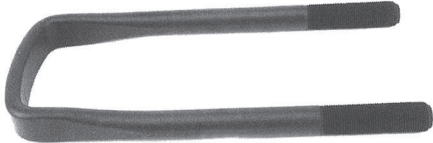
THE ORIGINAL NUMBERS OF THE VEHICLE MANUFACTURER MAY BE USED FOR COMPARISON PURPOSES ONLY AND MUST NOT BE MENTIONED ON INVOICES TO VEHICLE OWNERS.

Application	Description	Details	Ref.	Erqo No.
BM 387/389, 393/395, 620/621/623/624, 625, 645/646/648/649, 655/656/658/659	<ul style="list-style-type: none"> EN Spring bolt kit DE Federbolzensatz FR Axe de ressort ES Juego de pernos de resorte PT Jogo reparo parafuso RU Комплект пальцев ушка рессоры 		395 320 0165	02.20828 
				
BM 387/389, 391/393, 619, 620/621/623/624, 625, 645/646/647/648, 649 655/656/657/658, 659	<ul style="list-style-type: none"> EN Spring bolt kit DE Federbolzensatz FR Jeu d'axes ES Juego de pernos de muelle PT Jogo reparo parafuso RU Комплект пальцев ушка рессоры 	Ø 25 x 140	395 320 0265	02.20829 
				
BM 625, 650/651/652/653, 654/655/656/657, 658/659	<ul style="list-style-type: none"> EN Rubber bearing DE Gummilager FR Silentbloc ES Cojinete de goma PT Coxim RU Сайлентблок 		000 322 0385	02.20846 
				
BM 625, 650/651/652/653, 654/655/656/657, 658/659 chassis K083163--	<ul style="list-style-type: none"> EN Rubber bearing front spring bracket DE Gummilager Vorderfederhalter FR Silentbloc ressort de support avant ES Cojinete de goma soporte muelle delantero PT Coxim suporte mola frente RU Резиновая подушка переднего кронштейна рессоры 		000 322 3285	02.20849 
				

THE ORIGINAL NUMBERS OF THE VEHICLE MANUFACTURER MAY BE USED FOR COMPARISON PURPOSES ONLY AND MUST NOT BE MENTIONED ON INVOICES TO VEHICLE OWNERS.

Application	Description	Details	Ref.	Erqo No.
BM 625, 650/651/652/653	<ul style="list-style-type: none"> EN Bushing DE Buchse FR Bague ES Cásquillo PT Vucha RU Втулка 		652 322 0050	02.20845 
				
BM 385/387/389/393, 395/619/620/621, 622/623/624/625, 645/646/647/649, 653/654/655/656, 657/658/659	<ul style="list-style-type: none"> EN U-bolt DE U-Bolzen FR Bride de ressort ES Bulón en U PT Parafuso-U RU Скоба 	275 x 91 mm / M 20	304 331 1925	02.21031 
				
BM 395	<ul style="list-style-type: none"> EN Center bolt DE Zentrierbolzen FR Boulon centre ES Perno central PT Parafuso central RU Центровочный болт 	M 14 x 1,5	326 321 0071	02.20840 
				
BM 625.374/387/387/392, 655.307/337, 656/659	<ul style="list-style-type: none"> EN Spring bolt DE Federbolzen FR Axe de ressort ES Perno de muelle PT Parafuso RU Палец ушка рессоры 	M 14 x 1,5	347 321 0171	02.20841 
				
NG/MK/SK	<ul style="list-style-type: none"> EN Rubber buffer, leaf spring DE Gummipuffer, Blattfeder FR Silentbloc, ressort à lames ES Tope de goma, Ballesta PT Coxim, Mola RU Резиновый буфер 		655 331 0044	02.21032 
				
NG/MK	<ul style="list-style-type: none"> EN Rubber buffer, leaf spring DE Gummipuffer, Blattfeder FR Silentbloc, ressort à lames ES Tope de goma, Ballesta PT Coxim, Mola RU Резиновый буфер 		001 987 1140	02.22404 
				

THE ORIGINAL NUMBERS OF THE VEHICLE MANUFACTURER MAY BE USED FOR COMPARISON PURPOSES ONLY AND MUST NOT BE MENTIONED ON INVOICES TO VEHICLE OWNERS.

Suspension, Front Axle









Federung, Vorderachse • Suspension, Essieu Avant • Suspensión, Eje Delantero
 Suspensão, Eixo Dianteiro • Подвеска, передняя ось

Application	Description	Details	Ref.	Erqo No.
NG/MK/SK	<ul style="list-style-type: none"> EN Extra spring DE Zusatzfeder FR Ressort auxiliaire ES Ballesta adicional PT Coxim RU Буфер 		383 324 0008	02.20895 

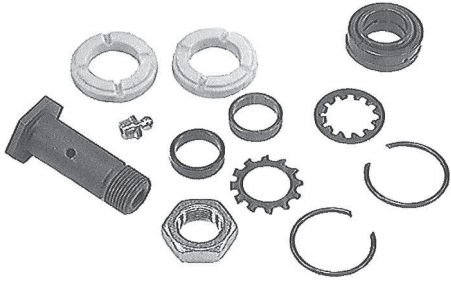

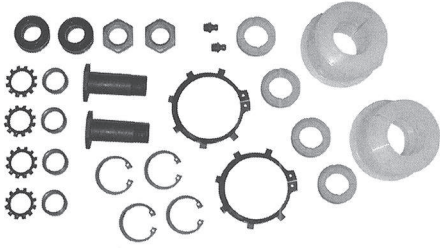

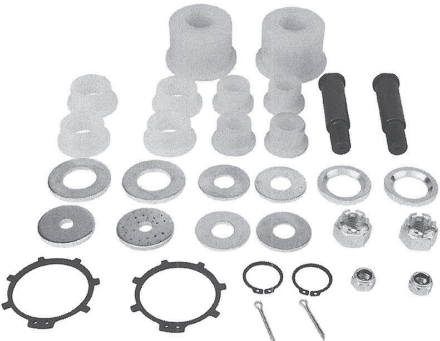



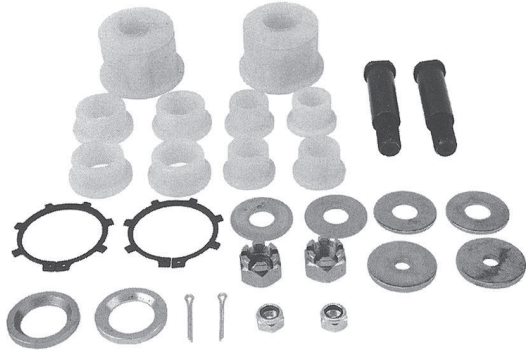

Stabilizer, Front Axle

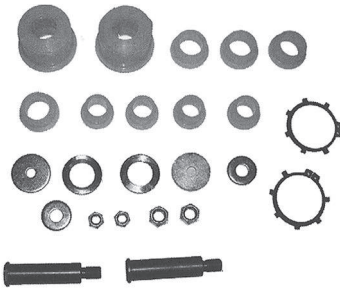

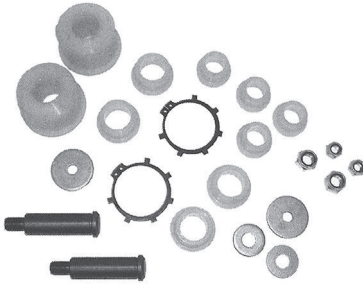

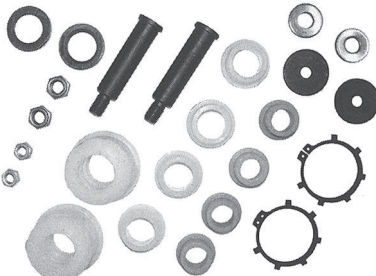





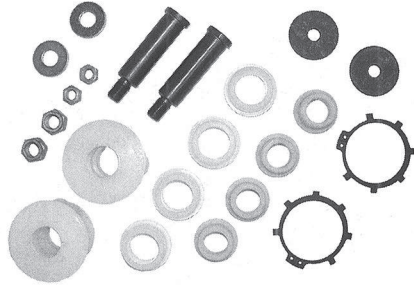

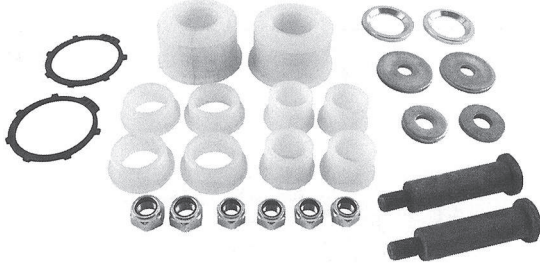
Stabilisator, Vorderachse • Stabilisateur, Essieu Avant • Estabilizador, Eje Delantero >
Estabilizador, Eixo Dianteiro • Стабилизатор, передняя ось

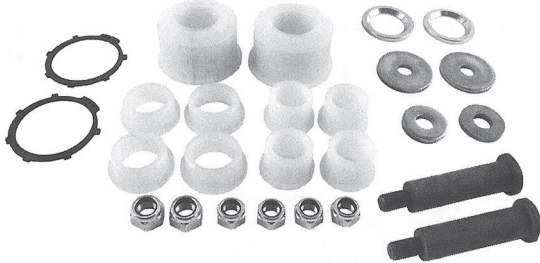
Application	Description	Details	Ref.	Erqo No.
BM 615/616/617/619	<ul style="list-style-type: none"> EN Rod, stabilizer DE Stange, Stabilisator FR Tige, Stabilisateur ES Barra, Estabilizador PT Haste, estabilizadora RU Штанга, Стабилизатор 		617 320 0089	02.20835 
BM 383/385	<ul style="list-style-type: none"> EN Repair kit, stabilizer DE Reparatursatz, Stabilisator FR Kit de réparation, Stabilisateur ES Kit de reparación, Estabilizador PT Reparo barra estabilizadora RU Ремкомплект, Стабилизатор 		360 320 0041	02.20819 
BM 615/616/617/619	<ul style="list-style-type: none"> EN Repair kit, stabilizer DE Reparatursatz, Stabilisator FR Kit de réparation, Stabilisateur ES Kit de reparación, Estabilizador PT Reparo barra estabilizadora RU Ремонтный комплект, Стабилизатор 		617 320 0128	02.20806 
BM 387/389, 391/393/395 --Id-No. 4394060	<ul style="list-style-type: none"> EN Repair kit, stabilizer DE Reparatursatz, Stabilisator FR Kit de réparation, barre stabilisatrice ES Kit de reparación, Estabilizador PT Reparo barra estabilizadora RU Ремонтный комплект, Стабилизатор 		387 320 0028	02.20801 

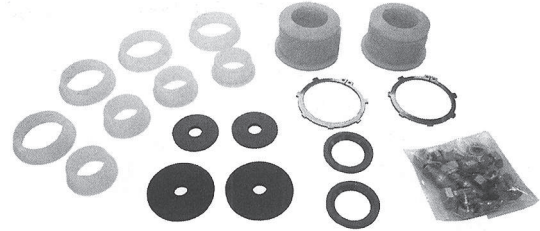

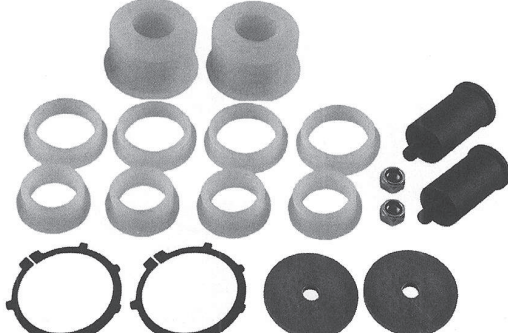

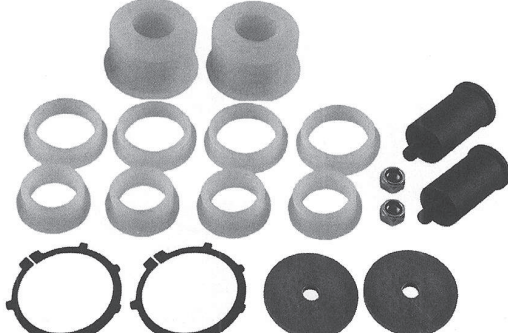
THE ORIGINAL NUMBERS OF THE VEHICLE MANUFACTURER MAY BE USED FOR COMPARISON PURPOSES ONLY AND MUST NOT BE MENTIONED ON INVOICES TO VEHICLE OWNERS.

Application	Description	Details	Ref.	Erqo No.
1626, 1632, 1926, 1932, 2626, 2632	<ul style="list-style-type: none"> EN Repair kit, stabilizer DE Reparatursatz, Stabilisator FR Kit de réparation, barre stabilisatrice ES Kit de reparación, Estabilizador PT Reparo barra estabilizadora RU Ремонтный комплект, Стабилизатор 		620 320 0228	02.20809 
BM 620/621/623/624, 625 --Id-No. 5184731	<ul style="list-style-type: none"> EN Repair kit, stabilizer DE Reparatursatz, Stabilisator FR Kit de réparation, Stabilisateur ES Kit de reparación, Estabilizador PT Reparo barra estabilizadora RU Ремкомплект, Стабилизатор 		620 320 0428	02.20811 
BM 620/621/623/624, 625 Id-No. 5184732--; BM 619, 645/646/648, 653/655/656/657, 658/659	<ul style="list-style-type: none"> EN Repair kit, stabilizer DE Reparatursatz, Stabilisator FR Kit de réparation, Stabilisateur ES Kit de reparación, Estabilizador PT Reparo barra estabilizadora RU Ремкомплект, Стабилизатор 		620 320 0628	02.20812 
BM 621/624/625 (A/AK/AS) --Id-No. 5184731	<ul style="list-style-type: none"> EN Repair kit, stabilizer DE Reparatursatz, Stabilisator FR Kit de réparation, Stabilisateur ES Kit de reparación, Estabilizador PT Reparo barra estabilizadora RU Ремкомплект, Стабилизатор 		624 320 0028	02.20816 

THE ORIGINAL NUMBERS OF THE VEHICLE MANUFACTURER MAY BE USED FOR COMPARISON PURPOSES ONLY AND MUST NOT BE MENTIONED ON INVOICES TO VEHICLE OWNERS.

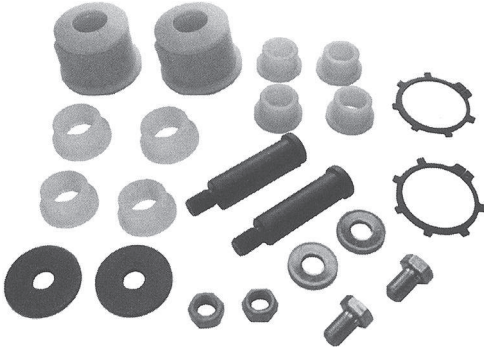







Application	Description	Details	Ref.	Erqo No.
BM 621/624/625 (A/AK/AS) Id-No. 5184732--;	<ul style="list-style-type: none"> EN Repair kit, stabilizer DE Reparatursatz, Stabilisator FR Kit de réparation, Stabilisateur ES Kit de reparación, Estabilizador PT Reparo barra estabilizadora RU Ремкомплект, Стабилизатор 		621 320 0228	02.20814 
BM 646/649, 655/659 (A/AK/AS)	<ul style="list-style-type: none"> EN Repair kit, stabilizer DE Reparatursatz, Stabilisator FR Kit de réparation, Stabilisateur ES Kit de reparación, Estabilizador PT Reparo barra estabilizadora RU Ремкомплект, Стабилизатор 		620 320 0128	02.20808 
BM 620/621/622/623 (L/LS), 625 (B/K) -- Id-No. 5184731	<ul style="list-style-type: none"> EN Repair kit, stabilizer DE Reparatursatz, Stabilisator FR Kit de réparation, Stabilisateur ES Kit de reparación, Estabilizador PT Reparo barra estabilizadora RU Ремкомплект, Стабилизатор 		620 320 0128	02.20808 
BM 625 Id-No. 5536638--	<ul style="list-style-type: none"> EN Repair kit, stabilizer 2nd front axle DE Reparatursatz, Stabilisator 2. Vorderachse FR Kit de réparation, Stabilisateur 2ème essieu avant ES Kit de reparación, Estabilizador 2º eje delantero PT Reparo barra estabilizadora 2º eixo da frente RU Ремкомплект, Стабилизатор 2-й передней оси 		625 320 0711	02.20799 
BM 620/621/622/623 (L/LS), 625 (B/K) Id-No. 5184732--;	<ul style="list-style-type: none"> EN Repair kit, stabilizer front axle DE Reparatursatz, Stabilisator Vorderachse FR Kit de réparation, Stabilisateur essieu avant ES Kit de reparación, Estabilizador eje delantero PT Reparo barra estabilizadora eixo da frente RU Ремкомплект, Стабилизатор передней оси 		621 320 0428	02.20815 
BM 645/646/647/648 (L/LL/LS); 655/656/657/658 (L/LS)	<ul style="list-style-type: none"> EN Repair kit, stabilizer front axle DE Reparatursatz, Stabilisator Vorderachse FR Kit de réparation, Stabilisateur essieu avant ES Kit de reparación, Estabilizador eje delantero PT Reparo barra estabilizadora eixo da frente RU Ремкомплект, Стабилизатор передней оси 		621 320 0428	02.20815 

THE ORIGINAL NUMBERS OF THE VEHICLE MANUFACTURER MAY BE USED FOR COMPARISON PURPOSES ONLY AND MUST NOT BE MENTIONED ON INVOICES TO VEHICLE OWNERS.

Application	Description	Details	Ref.	Erqo No.
BM 651/652/653/654 --Id-No. 5903513	<ul style="list-style-type: none"> EN Repair kit, stabilizer DE Reparatursatz, Stabilisator FR Kit de réparation, Stabilisateur ES Kit de reparación, Estabilizador PT Reparo barra estabilizadora RU Ремкомплект, Стабилизатор 		625 320 0611	02.20798 
BM 385/387/389, 395 --Id-No. 4707917	<ul style="list-style-type: none"> EN Bushing, stabilizer DE Buchse, Stabilisator FR Bague, barre stabilisatrice ES Casquillo, Estabilizador PT Bucha, estabilizadora RU Втулка, Стабилизатор 	Ø 37 / 70 x 62 mm	000 323 3785	02.20888 
BM 387/389/393 (L/LS) --Id-No. 4707618	<ul style="list-style-type: none"> EN Bushing DE Buchse FR Bague ES Casquillo PT Bucha RU Втулка 		000 326 1581	02.20961 
BM 385/387/389, 395 Id-No. 4707918--; BM 619, 620/621/623/625, 645/646/647.110, 648/649; 652/653/654/655, 656/657/658/659	<ul style="list-style-type: none"> EN Bushing, stabilizer DE Buchse, Stabilisator FR Bague, barre stabilisatrice ES Casquillo, Estabilizador PT Bucha, estabilizadora RU Втулка, Стабилизатор 	Ø 37 / 70 x 62 mm	387 323 0285	02.20891 

Application	Description	Details	Ref.	Erqo No.
BM 387/389/393 (L/LS) Id-No. 4707619--;	<ul style="list-style-type: none"> EN Bushing DE Buchse FR Bague ES Casquillo PT Bucha RU Втулка 		387 323 0385	02.20893 
BM 615/616/617/619, 621/624/625, 650/651/652 (L/LS/A/AK)	<ul style="list-style-type: none"> EN Bushing DE Buchse FR Bague ES Casquillo PT Bucha RU Втулка 		620 323 0250	02.20882 
4 BM 621/623/624, 645/646/647/649, 650/651/652/653, 654/655/656/657, 658/659	<ul style="list-style-type: none"> EN Bushing DE Buchse FR Bague ES Casquillo PT Bucha RU Втулка 		387 326 0181	02.20966 
BM 389/393, 620/621/623 (L/LS) 625 (BIK) --Id-No. 5184731	<ul style="list-style-type: none"> EN Bushing DE Buchse FR Bague ES Casquillo PT Bucha RU Втулка 		387 326 0281	02.20967 
BM 389/393, 620/621/623 (L/LS) 625 (B/K) Id-No. 5184732--	<ul style="list-style-type: none"> EN Bushing, stabilizer DE Buchse, Stabilisator FR Bague, barre stabilisatrice ES Casquillo, Estabilizador PT Bucha, estabilizadora RU Втулка, Стабилизатор 	Ø 46 / 86 x 63 mm	387 326 0281	02.20967 
BM 389/395, 616/617/619, 620/621/623/624, 625, 645/646, 650/651/652/653, 654/655/656/657, 658/659	<ul style="list-style-type: none"> EN Bushing, stabilizer DE Buchse, Stabilisator FR Bague, barre stabilisatrice ES Casquillo, Estabilizador PT Bucha, estabilizadora RU Втулка, Стабилизатор 	Ø 32 / 44 x 25 mm	000 323 2150	02.20878 

Stabilizer, Front AxleStabilisator, Vorderachse • Stabilisateur, Essieu Avant • Estabilizador, Eje Delantero >
Estabilizador, Eixo Dianteiro • Стабилизатор, передняя ось

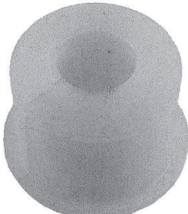
Application	Description	Details	Ref.	Erqo No.
BM 385/387/389, 391/393/395, 648/653/658	EN Bushing, stabilizer DE Buchse, Stabilisator FR Vague, barre stabilisatrice ES Casquillo, Estabilizador PT Vucha, estabilizadora RU Втулка, Стабилизатор	Ø 25 / 35 x 28 mm	000 323 0950	02.20876 
				
BM 387/389, 615/616/617/619, 620/621/623/624, 625, 645/646/647/648, 655/656/657/658, 659	EN Bushing, stabilizer DE Buchse, Stabilisator FR Vague, barre stabilisatrice ES Casquillo, Estabilizador PT Vucha, estabilizadora RU Втулка, Стабилизатор	Ø 41 / 52 x 25 mm	000 326 0650	02.20957 
				
BM 387/389, 391/393	EN Bushing, stabilizer DE Buchse, Stabilisator FR Vague, barre stabilisatrice ES Casquillo, Estabilizador PT Vucha, estabilizadora RU Втулка, Стабилизатор	Ø 32 / 44 x 35 mm	000 326 0250	02.20955 
				
BM 619, 620/621/623/624, 625	EN Bushing DE Buchse FR Vague ES Casquillo PT Vucha RU Втулка		620 323 0050	02.20880 
				
BM 621/624/625, 646/649, 655/656/659	EN Bushing DE Buchse FR Vague ES Casquillo PT Vucha RU Втулка		621 323 0085	02.20894 
				

THE ORIGINAL NUMBERS OF THE VEHICLE MANUFACTURER MAY BE USED FOR COMPARISON PURPOSES ONLY AND MUST NOT BE MENTIONED ON INVOICES TO VEHICLE OWNERS.

Application	Description	Details	Ref.	Erqo No.
BM 620/621/622/623, 624/625, 645/646/647/648, 655/656/657/658, 659	<ul style="list-style-type: none"> EN Bushing DE Buchse FR Vague ES Casquillo PT Vucha RU Втулка 		387 326 0050	02.20959 
4 BM 620/621/622/623, 625, 645/646/647/648, 655/656/657/658	<ul style="list-style-type: none"> EN Bushing DE Buchse FR Vague ES Casquillo PT Vucha RU Втулка 		620 323 0150	02.20881 
BM 620/621/622/623, 645/646/647/648, 652/655/656/657, 658	<ul style="list-style-type: none"> EN Bushing DE Buchse FR Vague ES Casquillo PT Vucha RU Втулка 		620 323 0350	02.20883 
BM 380/381/383/385	<ul style="list-style-type: none"> EN Bushing DE Buchse FR Vague ES Casquillo PT Vucha RU Втулка 		360 323 0085	02.20890 
BM 651/652/653	<ul style="list-style-type: none"> EN Bushing DE Buchse FR Silentbloc ES Casquillo PT Vucha RU Втулка 		000 326 2481	02.20964 

THE ORIGINAL NUMBERS OF THE VEHICLE MANUFACTURER MAY BE USED FOR COMPARISON PURPOSES ONLY AND MUST NOT BE MENTIONED ON INVOICES TO VEHICLE OWNERS.

Stabilizer, Front Axle









Stabilisator, Vorderachse • Stabilisateur, Essieu Avant • Estabilizador, Eje Delantero >
Estabilizador, Eixo Dianteiro • Стабилизатор, передняя ось

Application	Description	Details	Ref.	Erqo No.
BM 650/651/652/653, 654 Id-No. 5903514--	EN Bushing DE Buchse FR Vague ES Cásquillo PT Vucha RU Втулка		000 323 5885	02.20889 

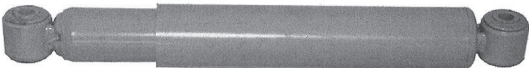



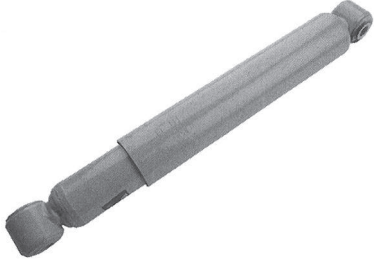



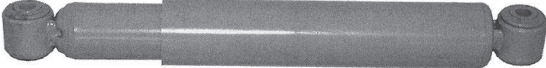

Shock Absorber, Front Axle

Stoßdämpfer, Vorderachse • Amortisseur, Essieu Avant • Amortiguador, Eje Trasero
 Amortecedor, Eixo Dianteiro • Амортизаторы, передняя ось

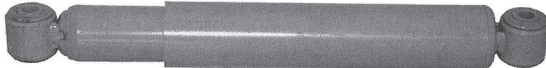
Application	Description	Details	Ref.	Erqo No.
BM 387/389, 391/393/395, 621.214/215,312, 621,322, 624.032/033/131, 646.322, 659 (L/LS)	<ul style="list-style-type: none"> EN Shock absorber front axle DE Stoßdämpfer Vorderachse FR Amortisseur essieu avant ES Amortiguador eje delantero PT Amortecedor eixo frente RU Амортизатор передней оси 		004 323 4500	02.20863 
4 BM 620/621/623/625, 645/646, 655/656/658 (L/LS/S) --Id-No. 4866170	<ul style="list-style-type: none"> EN Shock absorber Vorderachse DE Stoßdämpfer Vorderachse FR Amortisseur essieu avant ES Amortiguador eje delantero PT Amortecedor eixo frente RU Амортизатор передней оси 		006 323 0900	02.20874 
BM 387/389, 395, 621/624/625, 655/656/658/659 (A/AK)	<ul style="list-style-type: none"> EN Shock absorber DE Stoßdämpfer FR Amortisseur ES Amortiguador PT Amortecedor RU Амортизатор 		006 323 0700	02.20872 
BM 620/621/623, 645/648, 655/657/658 (S/LS) Id-No. 4866171--	<ul style="list-style-type: none"> EN Shock absorber front axle DE Stoßdämpfer Vorderachse FR Amortisseur essieu avant ES Amortiguador eje delantero PT Amortecedor eixo frente RU Амортизатор передней оси 		006 323 0800	02.20873 

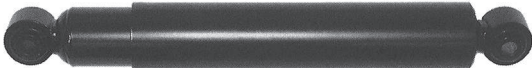
THE ORIGINAL NUMBERS OF THE VEHICLE MANUFACTURER MAY BE USED FOR COMPARISON PURPOSES ONLY AND MUST NOT BE MENTIONED ON INVOICES TO VEHICLE OWNERS.

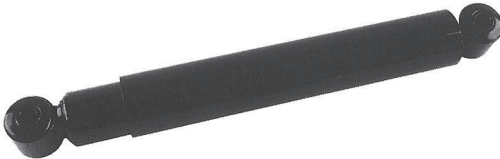
Shock Absorber, Front AxleStoßdämpfer, Vorderachse • Amortisseur, Essieu Avant • Amortiguador, Eje Trasero
Amortecedor, Eixo Dianteiro • Амортизаторы, передняя ось



Application	Description	Details	Ref.	Erqo No.
BM 387/389, 621/624/625, 649, 655/656/659 (A/AK)	<p>EN Shock absorber front axle</p> <p>DE Stoßdämpfer Vorderachse</p> <p>FR Amortisseur essieu avant</p> <p>ES Amortiguador eje delantero</p> <p>PT Amortecedor eixo frente</p> <p>RU Амортизатор передней оси</p>		003 323 9700	02.20860 
BM 615/616/617, 650/651/652 (S/LS) --Id-No. 5903513	<p>EN Shock absorber front axle</p> <p>DE Stoßdämpfer Vorderachse</p> <p>FR Amortisseur essieu avant</p> <p>ES Amortiguador eje delantero</p> <p>PT Amortecedor eixo frente</p> <p>RU Амортизатор передней оси</p>		004 323 6800	02.20867 
BM 625 -- chassis 6900225	<p>EN Shock absorber front axle</p> <p>DE Stoßdämpfer Vorderachse</p> <p>FR Amortisseur essieu avant</p> <p>ES Amortiguador eje delantero</p> <p>PT Amortecedor eixo frente</p> <p>RU Амортизатор передняя ось</p>		004 323 4700	02.20865 
BM 625	<p>EN Shock absorber 2nd front axle</p> <p>DE Stoßdämpfer 2. Vorderachse</p> <p>FR Amortisseur 2ème essieu avant</p> <p>ES Amortiguador 2o eje delantero</p> <p>PT Amortecedor 2o eixo da frente</p> <p>RU Амортизатор 2-й передней оси</p>		004 323 9700	02.20870 

Sample

Sample







Shock Absorber, Front Axle



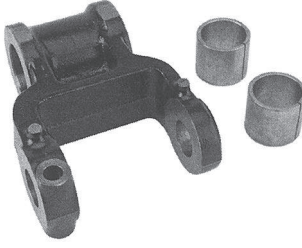

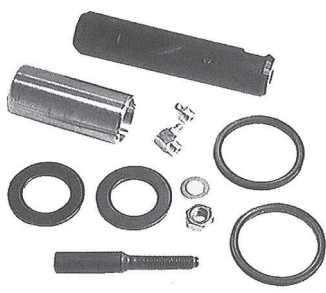
Stoßdämpfer, Vorderachse • Amortisseur, Essieu Avant • Amortiguador, Eje Trasero
 Amortecedor, Eixo Dianteiro • Амортизаторы, передняя ось

Application	Description	Details	Ref.	Erqo No.
NG/MK/SK	<ul style="list-style-type: none"> EN Rubber bearing, shock absorber DE Gummilager, Stoßdämpfer FR Silentbloc, amortisseur ES Cojinete de goma, amortiguador PT Coxim, amortecedor RU Саленблок, Амортизатор 		000 323 2885	02.20886 

4

MK/SK	<ul style="list-style-type: none"> EN Rubber bearing, shock absorber DE Gummilager, Stoßdämpfer FR Silentbloc, amortisseur ES Cojinete de goma, Amortiguador PT Coxim, amortecedor RU Сайлентблок, Амортизатор 		000 323 3144	02.20875 
-------	--	---	--------------	--

Application	Description	Details	Ref.	Erqo No.
BM 389, 621, 655/656	<ul style="list-style-type: none"> EN Spring shackle rear axle DE Federschwinge Hinterachse FR Jumelle essieu arrière ES Gemela de ballesta eje trasero PT Jumelo molejo eixo trazeiro RU Серьга рессоры задней оси 		621 325 0020	02.20923 
BM 381/385, 616/617/619	<ul style="list-style-type: none"> EN Spring bolt kit DE Federbolzensatz FR Axe de ressort ES Juego de pernos de resorte PT Jogo reparo parafuso RU Комплект пальцев ушка рессоры 		385 320 0065	02.20824 
BM 387/389/393, 620/621/623, 645/646/647/648, 655/656/657/658	<ul style="list-style-type: none"> EN Spring bolt kit DE Federbolzensatz FR Jeu d'axes ES Juego de pernos de muelle PT Jogo reparo parafuso RU Комплект пальцев ушка рессоры 	Ø 30 x 148	389 320 0065	02.20826 
BM 620/621/623, 645/646/648, 655/656/658	<ul style="list-style-type: none"> EN Spring bolt kit DE Federbolzensatz FR Jeu d'axes ES Juego de pernos de muelle PT Jogo reparo parafuso RU Комплект пальцев ушка рессоры 	Ø 30 x 160	658 320 0065	02.20830 

Application	Description	Details	Ref.	Erqo No.
BM 387/389, 621, 646, 655 (A/AK)	<ul style="list-style-type: none"> EN Spring bolt kit DE Federbolzensatz FR Axe de ressort ES Juego de pernos de resorte PT Jogo reparo parafuso RU Комплект пальцев ушка рессоры 		389 320 0265	02.20827 
4 BM 395/624/625/649, 659	<ul style="list-style-type: none"> EN U-bolt DE U-Bolzen FR Bride de ressort ES Bulón en U PT Parafuso-U RU Скоба 	340 x 101 mm / M 24	395 351 0125	02.21102 
BM 625.392 -- chassis 6900031	<ul style="list-style-type: none"> EN U-bolt DE U-Bolzen FR Bride de ressort ES Bulón en U PT Parafuso-U RU Скоба 	470 x 101 mm / M 24 x 1,5	395 351 0425	02.21103 
BM 387/389/620/621, 645/647/655/656	<ul style="list-style-type: none"> EN U-bolt DE U-Bolzen FR Bride de ressort ES Bulón en U PT Parafuso-U RU Скоба 	515 x 1 01 mm / M 24 x 1,5	620 351 0125	02.21104 
BM 387/389/656	<ul style="list-style-type: none"> EN U-bolt DE U-Bolzen FR Bride de ressort ES Bulón en U PT Parafuso-U RU Скоба 	555 x 101 mm / M 24 x 1,5	389 351 0025	02.21101 

THE ORIGINAL NUMBERS OF THE VEHICLE MANUFACTURER MAY BE USED FOR COMPARISON PURPOSES ONLY AND MUST NOT BE MENTIONED ON INVOICES TO VEHICLE OWNERS.

Application	Description	Details	Ref.	Erqo No.
BM 385/393/395/619, 623/624/625/648, 649/653/658/659	EN Washer, for u-bolt DE Scheibe, für U-Bolzen FR Rondelle, pour bride de ressort ES Arandela, para bulón en U PT Arruela, para parafuso-u RU Шайба, для скобы		343 325 0070	02.20930 
				
BM 387/391/395/624, 625/645/649/659	EN Center bolt DE Zentrierbolzen FR Boulon centre ES Perno central PT Parafuso central RU Центровочный болт	M 18 x 1,5	347 324 0271	02.20897 
				
BM 625.392 -- chassis 6900031	EN Center bolt DE Zentrierbolzen FR Boulon centre ES Perno central PT Parafuso central RU Центровочный болт	M 18 x 1,5	346 324 5271	02.20896 
				
BM 625.015/018/019, 648.137 --Id-No. 5248933	EN Spring bracket DE Federhalter FR Support de ressort ES Portamuelles PT Suporte feixe mola RU Кронштейн рессоры	92 mm	624 325 0219	02.20909 
				
BM 625.015/018/019, 648.137 --Id-No. 5248933	EN Spring bracket DE Federhalter FR Support de ressort ES Portamuelles PT Suporte feixe mola RU Кронштейн рессоры	92 mm	624 325 0319	02.20910 
				

THE ORIGINAL NUMBERS OF THE VEHICLE MANUFACTURER MAY BE USED FOR COMPARISON PURPOSES ONLY AND MUST NOT BE MENTIONED ON INVOICES TO VEHICLE OWNERS.

Suspension, Rear Axle

Federung, Hinterachse • Suspension, Essieu Arrière • Suspensión, Eje Trasero Suspensão, Eixo Traseiro • Подвеска, задняя ось



Application	Description	Details	Ref.	Erqo No.
BM 625, 648.137, 658.132/134/137, 658.139/147/149 -- Id-No. 5248933	<ul style="list-style-type: none"> EN Spring bracket DE Federhalter FR Support de ressort ES Portamuelles PT Suporte feixe mola RU Кронштейн рессоры 	108 mm	625 325 0319	02.20920 
				
BM 625, 648.137, 658.132/134/137, 658.139/147/149 -- Id-No. 5248933	<ul style="list-style-type: none"> EN Spring bracket DE Federhalter FR Support de ressort ES Portamuelles PT Suporte feixe mola RU Кронштейн рессоры 	108 mm	625 325 0219	02.20919 
				
BM 395, 624/625, 649, 659 Id-No. 5248934--	<ul style="list-style-type: none"> EN Spring bracket DE Federhalter FR Support de ressort ES Portamuelles PT Suporte feixe mola RU Кронштейн рессоры 	76 mm	625 325 0019	02.20917 
				
BM 395, 624/625, 649, 659 Id-No. 5248934--	<ul style="list-style-type: none"> EN Spring bracket DE Federhalter FR Support de ressort ES Portamuelles PT Suporte feixe mola RU Кронштейн рессоры 	76 mm	625 325 0119	02.20918 
				

THE ORIGINAL NUMBERS OF THE VEHICLE MANUFACTURER MAY BE USED FOR COMPARISON PURPOSES ONLY AND MUST NOT BE MENTIONED ON INVOICES TO VEHICLE OWNERS.







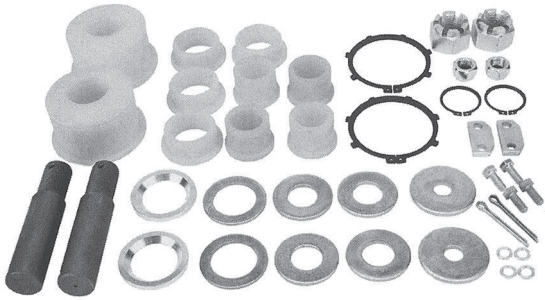

Application	Description	Details	Ref.	Erqo No.
BM 625.052/054/057, 625.249, 625.258/259/269, 625.374/382/387, 625.392 K007937--	<ul style="list-style-type: none"> EN Spring bracket DE Federhalter FR Axe de ressort ES Soporte de ballesta PT Suporte feixe mola RU Кронштейн рессоры 		659 325 0019	02.20921 
BM 625.052/054/057, 625.249, 625.258/259/269, 625.374/382/387, 625.392 K007937--	<ul style="list-style-type: none"> EN Spring bracket DE Federhalter FR Axe de ressort ES Soporte de ballesta PT Suporte feixe mola RU Кронштейн рессоры 		659 325 0119	02.20922 
BM 395, 624/625, 658/659	<ul style="list-style-type: none"> EN Bearing bracket DE Lagerbock FR Axe de palier ES Soporte de cojinete PT Suporte feixe mola RU Кронштейн подшипника 		395 325 1109	02.20902 
BM 395, 624/625, 649, 659	<ul style="list-style-type: none"> EN Rubber mounting DE Gummipuffer FR Silentbloc ES Tope de goma PT Coxim RU Резиновый буфер 		343 325 0044	02.20924 
NG/MK/SK	<ul style="list-style-type: none"> EN Screw DE Schraube FR Vis ES Tornillo PT Parafuso RU Болт 	M 20 x 1,5 x 205	659 990 0001	02.22433 
				

Sample

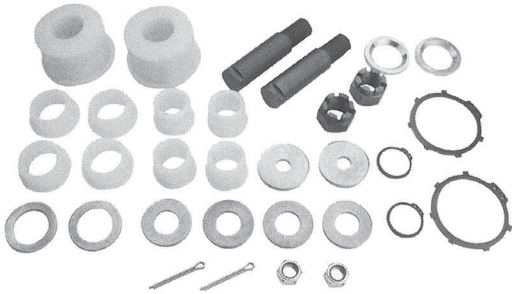
Suspension, Rear AxleFederung, Hinterachse • Suspension, Essieu Arrière • Suspensión,
Eje Trasero Suspensão, Eixo Traseiro • Подвеска, задняя ось

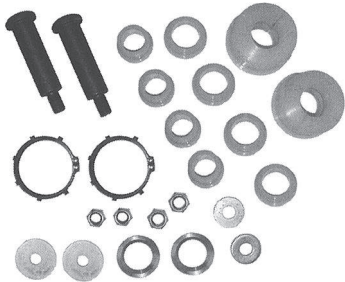

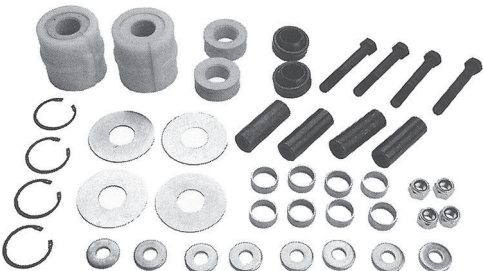



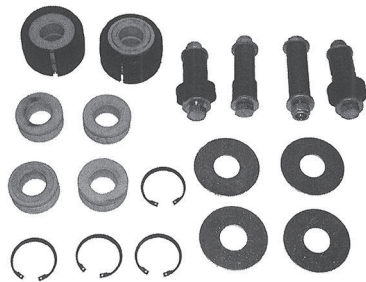

Application	Description	Details	Ref.	Erqo No.
NG/MK/SK	<ul style="list-style-type: none">EN Spherical washerDE KugelscheibeFR Rondelle sphériqueES Arandela esféricaPT Aruela esférica apolo molaRU Сферическая шайба		659 997 0126	02.22587 

Stabilizer, Rear AxleStabilisator, Hinterachse • Stabilisateur, Essieu Arrière • Estabilizador, Eje Trasero
Estabilizador, Eixo Traseiro • Стабилизатор, задняя ось

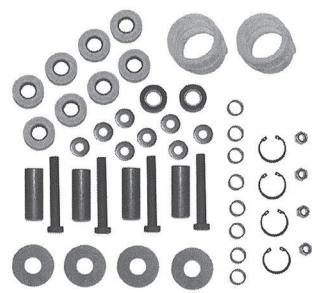
Application	Description	Details	Ref.	Erqo No.
BM 387/389 --Id-No. 4707917	<ul style="list-style-type: none"> EN Repair kit, stabilizer DE Reparatursatz, Stabilisator FR Kit de réparation, barre stabilisatrice ES Kit de reparación, Estabilizador PT Reparo barra estabilizadora RU Ремонтный комплект, Стабилизатор 		387 320 0128	02.20802 
BM 387/389 Id-No. 4707918--	<ul style="list-style-type: none"> EN Repair kit, stabilizer DE Reparatursatz, Stabilisator FR Kit de réparation, barre stabilisatrice ES Kit de reparación, Estabilizador PT Reparo barra estabilizadora RU Ремонтный комплект 		387 320 0528	02.20804 
BM 620/621, 645/647/648, 650, 655/656/657/658	<ul style="list-style-type: none"> EN Repair kit, stabilizer DE Reparatursatz, Stabilisator FR Kit de réparation, Stabilisateur ES Kit de reparación, Estabilizador PT Reparo barra estabilizadora RU Ремкомплект, Стабилизатор 		620 320 0028	02.20807 
BM 387/393, 620/622/623, 645/647/648, 655/657/658 (L/LS) --Id-No. 5554754	<ul style="list-style-type: none"> EN Repair kit, stabilizer DE Reparatursatz, Stabilisator FR Kit de réparation, Stabilisateur ES Kit de reparación, Estabilizador PT Reparo barra estabilizadora RU Ремкомплект, Стабилизатор 		387 320 0328	02.20803 

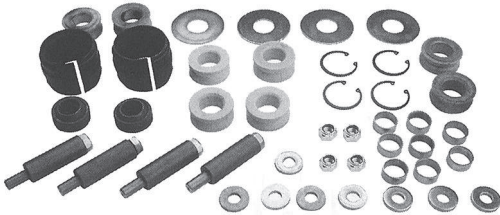
Stabilizer, Rear Axle







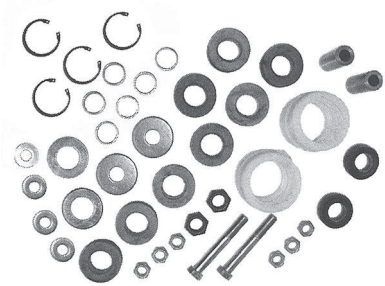

Stabilisator, Hinterachse • Stabilisateur, Essieu Arrière • Estabilizador, Eje Trasero
Estabilizador, Eixo Traseiro • Стабилизатор, задняя ось

Application	Description	Details	Ref.	Erqo No.
BM 620/622/623, 645/647/648, 655/657/658 (L/LS) Id-No. 5554755--	EN Repair kit, stabilizer DE Reparatursatz, Stabilisator FR Kit de réparation, Stabilisateur ES Kit de reparación, Estabilizador PT Reparo barra estabilizadora RU Ремкомплект, Стабилизатор		620 320 0111	02.20796 
4 BM 389.213/223, 621, 646 (LS), 656.416 --Id-No. 5554754	EN Repair kit, stabilizer DE Reparatursatz, Stabilisator FR Kit de réparation, Stabilisateur ES Kit de reparación, Estabilizador PT Reparo barra estabilizadora RU Ремкомплект, Стабилизатор		621 320 0128	02.20813 
BM 621, 646 (LS), 656.416, 657/658 (L/LS) Id-No. 5554755--	EN Repair kit, stabilizer DE Reparatursatz, Stabilisator FR Kit de réparation, Stabilisateur ES Kit de reparación, Estabilizador PT Reparo barra estabilizadora RU Ремкомплект, Стабилизатор		621 320 0011	02.20797 
BM 385, 619, 653 (L/LL)	EN Repair kit, stabilizer trailing axle DE Reparatursatz, Stabilisator Nachlaufachse FR Kit de réparation, Stabilisateur essieu trainard ES Kit de reparación, Estabilizador eje de arrastre PT Reparo barra estabilizadora eixo morto RU Ремонтный комплект, Стабилизатор поддерживающей оси		620 320 0328	02.20810 

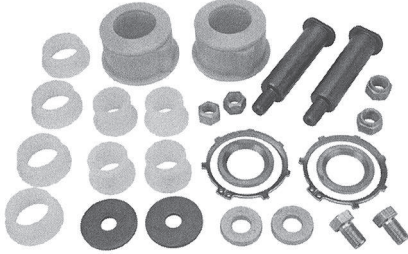
THE ORIGINAL NUMBERS OF THE VEHICLE MANUFACTURER MAY BE USED FOR COMPARISON PURPOSES ONLY AND MUST NOT BE MENTIONED ON INVOICES TO VEHICLE OWNERS.

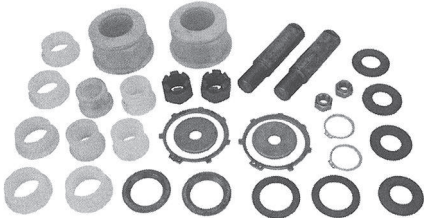
Stabilizer, Rear Axle

Stabilisator, Hinterachse • Stabilisateur, Essieu Arrière • Estabilizador, Eje Trasero
Estabilizador, Eixo Traseiro • Стабилизатор, задняя ось

Application	Description	Details	Ref.	Erqo No.
BM 383/385, 616/619 (L)	EN Repair kit, stabilizer DE Reparatursatz, Stabilisator FR Kit de réparation, Stabilisateur ES Kit de reparación, Estabilizador PT Reparo barra estabilizadora RU Ремонтный комплект, Стабилизатор		380 320 0028	02.20800 
BM 623/625, 648/658	EN Repair kit, stabilizer DE Reparatursatz, Stabilisator FR Kit de réparation, Stabilisateur ES Kit de reparación, Estabilizador PT Reparo barra estabilizadora RU Ремонтный комплект, Стабилизатор		623 320 0041	02.20820 
BM 393	EN Repair kit, stabilizer DE Reparatursatz, Stabilisator FR Kit de réparation, Stabilisateur ES Kit de reparación, Estabilizador PT Reparo barra estabilizadora RU Ремонтный комплект, Стабилизатор		393 320 0228	02.20805 
BM 387/389	EN Bushing, stabilizer DE Buchse, Stabilisator FR Bague, barre stabilisatrice ES Casquillo, Estabilizador PT Bucha, estabilizadora RU Втулка, Стабилизатор	Ø 45 / 85 x 62 mm	000 326 1681	02.20962 
BM 389/393, 620/621/623 (L/LS) 625 (B/K) Id-No. 5184732--	EN Bushing, stabilizer DE Buchse, Stabilisator FR Bague, barre stabilisatrice ES Casquillo, Estabilizador PT Bucha, estabilizadora RU Втулка, Стабилизатор	Ø 46 / 86 x 63 mm	387 326 0281	02.20968 

THE ORIGINAL NUMBERS OF THE VEHICLE MANUFACTURER MAY BE USED FOR COMPARISON PURPOSES ONLY AND MUST NOT BE MENTIONED ON INVOICES TO VEHICLE OWNERS.





Stabilizer, Rear Axle

Stabilisator, Hinterachse • Stabilisateur, Essieu Arrière • Estabilizador, Eje Trasero
Estabilizador, Eixo Traseiro • Стабилизатор, задняя ось

Application	Description	Details	Ref.	Erqo No.
BM 620/621/622/623, 624/625, 645/646/647/648, 655/656/657/658, 659	<ul style="list-style-type: none"> EN Bushing DE Buchse FR Vague ES Casquillo PT Vucha RU Втулка 		387 326 0050	02.20960 
4 BM 381/383/385/387, 393, 616/617/619, 620/621/622, 648, 655/657/658,	<ul style="list-style-type: none"> EN Bushing DE Buchse FR Vague ES Casquillo PT Vucha RU Втулка 		393 326 0281	02.20971 
BM 620/622/623, 645/647/648, 655/657 (LS)	<ul style="list-style-type: none"> EN Bushing DE Buchse FR Vague ES Casquillo PT Vucha RU Втулка 		655 326 0581	02.20977 
BM 389.213/223, 621, 646, 656 (L/LS)	<ul style="list-style-type: none"> EN Bushing DE Buchse FR Vague ES Casquillo PT Vucha RU Втулка 		389 326 0081	02.20970 
BM 621, 646, 655/656/657/658 (L/LS)	<ul style="list-style-type: none"> EN Bushing DE Buchse FR Vague ES Casquillo PT Vucha RU Втулка 		655 326 0481	02.20976 

THE ORIGINAL NUMBERS OF THE VEHICLE MANUFACTURER MAY BE USED FOR COMPARISON PURPOSES ONLY AND MUST NOT BE MENTIONED ON INVOICES TO VEHICLE OWNERS.

Stabilizer, Rear AxleStabilisator, Hinterachse • Stabilisateur, Essieu Arrière • Estabilizador, Eje Trasero
Estabilizador, Eixo Traseiro • Стабилизатор, задняя ось

Application	Description	Details	Ref.	Erqo No.
BM 385/387/389, 395 Id-No. 4707918--; BM 619, 620/621/623/625, 645/646/647.110, 648/649; 652/653/654/655, 656/657/658/659	EN Bushing, stabilizer DE Buchse, Stabilisator FR Bague, barre stabilisatrice ES Casquillo, Estabilizador PT Vucha, estabilizadora RU Втулка, Стабилизатор	Ø 37 / 70 x 62	387 323 0285	02.20892 
BM 387/389, 615/616/617/619, 620/621/623/624, 625, 645/646/647/648, 655/656/657/658, 659	EN Bushing, stabilizer DE Buchse, Stabilisator FR Bague, barre stabilisatrice ES Casquillo, Estabilizador PT Vucha, estabilizadora RU Втулка, Стабилизатор	Ø 41 / 52 x 25 mm	000 326 0650	02.20958 
BM 387/389, 391/393	EN Bushing, stabilizer DE Buchse, Stabilisator FR Bague, barre stabilisatrice ES Casquillo, Estabilizador PT Vucha, estabilizadora RU Втулка, Стабилизатор	Ø 32 / 44 x 35 mm	000 326 0250	02.20956 
BM 389/393, 620/621/623 (L/LS) 625 (B/K) Id-No. 5184732--	EN Bushing, stabilizer DE Buchse, Stabilisator FR Bague, barre stabilisatrice ES Casquillo, Estabilizador PT Vucha, estabilizadora RU Втулка, Стабилизатор	Ø 46 / 86 x 63 mm	387 326 0281	02.20968 
BM 387/393, 616/617/619, 620/621/622/623, 645/646/647, 651/652/653/654, 655/656/658	EN Bushing DE Buchse FR Bague ES Casquillo PT Vucha RU Втулка		380 323 0160	02.20884 









Stabilizer, Rear Axle

Stabilisator, Hinterachse • Stabilisateur, Essieu Arrière • Estabilizador, Eje Trasero
Estabilizador, Eixo Traseiro • Стабилизатор, задняя ось

Application	Description	Details	Ref.	Erqo No.
BM 380/381/383/385, 387/389, 393, 616/617/619, 620/621/622/623, 645/646/647/648, 655/656/657/658	<ul style="list-style-type: none"> EN Bushing DE Buchse FR Bague ES Casquillo PT Bucha RU Втулка 		380 323 0260	02.20885 
4 BM 389/395, 616/617/619, 620/621/623/624, 625, 645/646, 650/651/652/653, 654/655/656/657, 658/659	<ul style="list-style-type: none"> EN Bushing, stabilizer DE Buchse, Stabilisator FR Bague, barre stabilisatrice ES Casquillo, Estabilizador PT Bucha, estabilizadora RU Втулка, Стабилизатор 	Ø 32 / 44 x 25 mm 	000 323 2150	02.20879 
BM 385/387/389, 391/393/395, 648/653/658	<ul style="list-style-type: none"> EN Bushing, stabilizer DE Buchse, Stabilisator FR Bague, barre stabilisatrice ES Casquillo, Estabilizador PT Bucha, estabilizadora RU Втулка, Стабилизатор 	Ø 25 / 35 x 28 mm 	000 323 0950	02.20877 
BM 625, 650/651/652/654	<ul style="list-style-type: none"> EN Bushing, stabilizer DE Buchse, Stabilisator FR Silentbloc, stabilisateur ES Casquillo, estabilizador PT Bucha, estabilizador RU Втулка, Стабилизатор 		000 326 2681	02.20965 
BM 625, 650/651/652/653, 654	<ul style="list-style-type: none"> EN Bushing DE Buchse FR Bague ES Casquillo PT Bucha RU Втулка 		000 326 2381	02.20963 

THE ORIGINAL NUMBERS OF THE VEHICLE MANUFACTURER MAY BE USED FOR COMPARISON PURPOSES ONLY AND MUST NOT BE MENTIONED ON INVOICES TO VEHICLE OWNERS.









Stabilizer, Rear AxleStabilisator, Hinterachse • Stabilisateur, Essieu Arrière • Estabilizador, Eje Trasero
Estabilizador, Eixo Traseiro • Стабилизатор, задняя ось

Application	Description	Details	Ref.	Erqo No.
BM 651/652/653/654, 655/656/657/658 Id-No, K100578--	<ul style="list-style-type: none"> EN Rubber bearing, stabilizer DE Gummilager, Stabilisator FR Silentbloc, stabilisateur ES Cojinete de goma, estabilizador PT Coxim, estabilizador RU Сайлентблок, Стабилизатор 		653 326 0481	02.20975 
				
BM 651/652/653/654 Id-No. K100578--	<ul style="list-style-type: none"> EN Rubber bearing, stabilizer DE Gummilager, Stabilisator FR Silentbloc, stabilisateur ES Cojinete de goma, estabilizador PT Coxim, estabilizador RU Сайлентблок, Стабилизатор 	Ø 65 mm	652 326 0381	02.20973 
				
BM 651/652/653/654, 655 Id-No. K100578--	<ul style="list-style-type: none"> EN Rubber bearing, stabilizer rear axle DE Gummilager, Stabilisator Hinterachse FR Silentbloc, stabilisateur essieu arrière ES Cojinete de goma, estabilizador eje trasero PT Coxim, estabilizador eixo traseiro RU Сайлентблок задней оси 	Ø 70 mm	652 326 0481	02.20974 
				
BM 393, BM 623/625, BM 658	<ul style="list-style-type: none"> EN Bushing DE Buchse FR Bague ES Casquillo PT Bucha RU Втулка 		393 326 0481	02.20972 
	<ul style="list-style-type: none"> EN 2nd rear axle DE 2. Hinterachse FR 2ème essieu arrière ES 2º eje trasero PT 2o eixo traseiro RU 2. задней оси 			
				

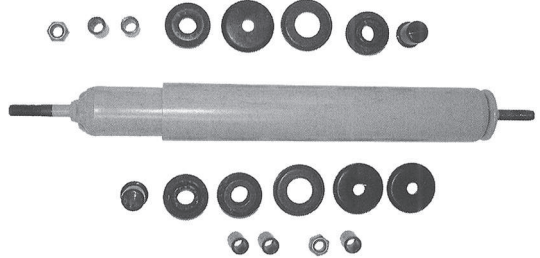
THE ORIGINAL NUMBERS OF THE VEHICLE MANUFACTURER MAY BE USED FOR COMPARISON PURPOSES ONLY AND MUST NOT BE MENTIONED ON INVOICES TO VEHICLE OWNERS.

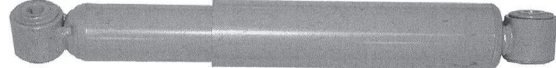

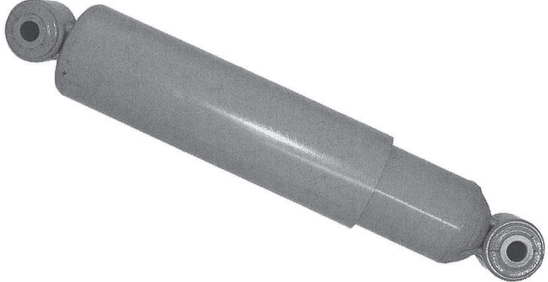



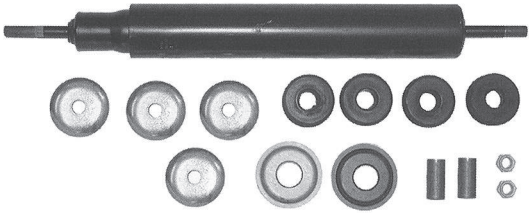

Shock Absorber, Rear Axle

Stoßdämpfer, Hinterachse • Amortisseur, Essieu Arrière • Amortiguador, Eje trasero
 Amortecedor, Eixo Traseiro • Амортизаторы, задняя ось

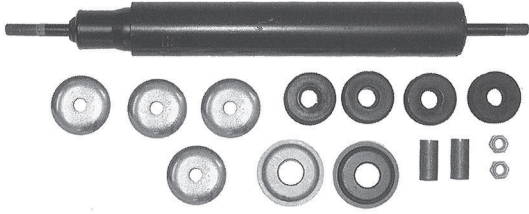
Application	Description	Details	Ref.	Erqo No.
BM 387/389	<ul style="list-style-type: none"> EN Shock absorber rear axle DE Stoßdämpfer Hinterachse FR Amortisseur essieu arrière ES Amortiguador eje trasero PT Amortecedor eixo traseiro RU Амортизатор задней оси 		391 326 0100	02.20952 
BM 621, 655/656	<ul style="list-style-type: none"> EN Shock absorber rear axle DE Stoßdämpfer Hinterachse FR Amortisseur essieu arrière ES Amortiguador eje trasero PT Amortecedor eixo traseiro RU Амортизатор задней оси 		621 326 0000	02.20954 
BM 620/621, 645/646/647, 655/657 (S)	<ul style="list-style-type: none"> EN Shock absorber rear axle DE Stoßdämpfer Hinterachse FR Amortisseur essieu arrière ES Amortiguador eje trasero PT Amortecedor eixo traseiro RU Амортизатор задней оси 		003 326 4400	02.20943 
BM 387, 393, 621, 645/646, 655 (LS)	<ul style="list-style-type: none"> EN Shock absorber rear axle DE Stoßdämpfer Hinterachse FR Amortisseur essieu arrière ES Amortiguador eje trasero PT Amortecedor eixo traseiro RU Амортизатор задней оси 		005 326 2000	02.20950 

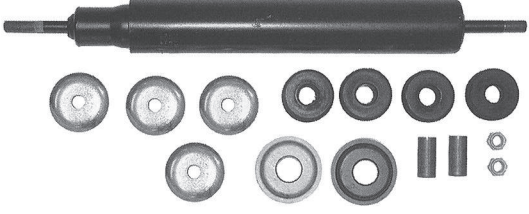
THE ORIGINAL NUMBERS OF THE VEHICLE MANUFACTURER MAY BE USED FOR COMPARISON PURPOSES ONLY AND MUST NOT BE MENTIONED ON INVOICES TO VEHICLE OWNERS.

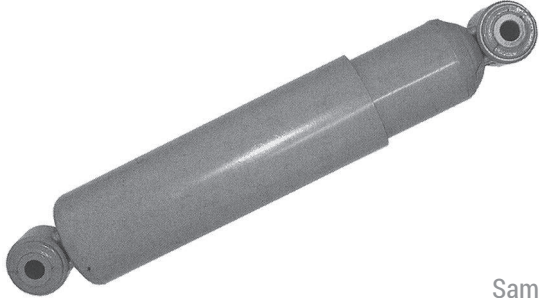
Shock Absorber, Rear AxleStoßdämpfer, Hinterachse • Amortisseur, Essieu Arrière • Amortiguador, Eje trasero
Amortecedor, Eixo Traseiro • Амортизаторы, задняя ось

Application	Description	Details	Ref.	Erqo No.
BM 387/389, 621, 656 (K)	<ul style="list-style-type: none"> EN Shock absorber rear axle DE Stoßdämpfer Hinterachse FR Amortisseur essieu arrière ES Amortiguador eje trasero PT Amortecedor eixo traseiro RU Амортизатор задняя ось 		387 326 0000	02.20951 
BM 651/652/653 (L)	<ul style="list-style-type: none"> EN Shock absorber rear axle DE Stoßdämpfer Hinterachse FR Amortisseur essieu arrière ES Amortiguador eje trasero PT Amortecedor eixo traseiro RU Амортизатор задней оси 		004 326 7000	02.20949 
BM 620, 645, 655	<ul style="list-style-type: none"> EN Shock absorber rear axle DE Stoßdämpfer Hinterachse FR Amortisseur essieu arrière ES Amortiguador eje trasero PT Amortecedor eixo traseiro RU Амортизатор задней оси 		620 326 0000	02.20953 
BM 655/656/658 (L) Id-No. 5922799--	<ul style="list-style-type: none"> EN Shock absorber rear axle DE Stoßdämpfer Hinterachse FR Amortisseur essieu arrière ES Amortiguador eje trasero PT Amortecedor eixo traseiro RU Амортизатор задней оси 		004 326 6400	02.20947 

Sample





Sample

Sample

THE ORIGINAL NUMBERS OF THE VEHICLE MANUFACTURER MAY BE USED FOR COMPARISON PURPOSES ONLY AND MUST NOT BE MENTIONED ON INVOICES TO VEHICLE OWNERS.

Shock Absorber, Rear Axle

Stoßdämpfer, Hinterachse • Amortisseur, Essieu Arrière • Amortiguador, Eje trasero
 Amortecedor, Eixo Traseiro • Амортизаторы, задняя ось

Application	Description	Details	Ref.	Erqo No.
BM 393, 623/625, 648, 658 (S/LS)	<ul style="list-style-type: none"> EN Shock absorber 1st and 2nd rear axle DE Stoßdämpfer 1. und 2. Hinterachse FR Amortisseur 1 er et 2ème essieu arrière ES Amortiguador 1º y 2º eje trasero PT Amortecedor 1º e 2º eixo traseiro RU Амортизатор 1-й и 2-й задней оси 		002 326 9200	02.20938 
4 NG/MK/SK	<ul style="list-style-type: none"> EN Rubber bearing, shock absorber DE Gummilager, Stoßdämpfer FR Silentbloc, amortisseur ES Cojinete de goma, amortiguador PT Coxim, amortecedor RU Саленблок, Амортизатор 		000 323 2885	02.20887 

Application	Description	Details	Ref.	Erqo No.
BM 619/620/622/645, 646/647/655/657	<ul style="list-style-type: none"> EN Air spring DE Luftfederbalg FR Coussin d'air ES Fuelle de suspensión neumática PT Câmara pneumática RU Пневматическая рессора 	repl. Conti: 673 N	383 327 0001	02.20978 
				
BM 385/389/393 621/623/648/653, 656/658	<ul style="list-style-type: none"> EN Air spring DE Luftfederbalg FR Coussin d'air ES Fuelle de suspensión neumática PT Câmara pneumática RU Пневматическая рессора 	repl. Conti: 737 N	363 328 0201	02.20981 
				
BM 385, 625/647/648/653 654/657/658	<ul style="list-style-type: none"> EN Air spring DE Luftfederbalg FR Coussin d'air ES Fuelle de suspensión neumática PT Câmara pneumática RU Пневматическая рессора 	repl. Conti: 757 N	363 328 0201	02.20981 
				

Air Spring

Luftfederbalg • Coussinet d'air pneumatique • Fuelle suspensión neumática
 Câmara ar • Пневматическая рессора

Application	Description	Details	Ref.	Erqo No.
BM 381/383/385/387, 393, BM 616/617/619/620, 623/645/651/652, 653/655/658	<ul style="list-style-type: none"> EN Air spring DE Luftfederbalg FR Coussin d'air ES Fuelle de suspensión neumática PT Câmara pneumática RU Пневматическая рессора 	repl. Conti: 720 N	387 328 0001	02.20982 



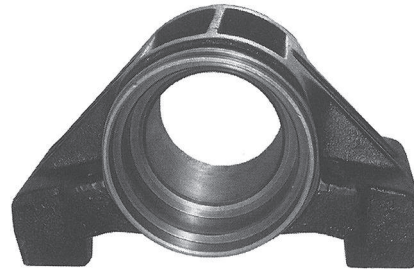

Spring SaddleFederwiege • Boîtier de bogie • Sillín / Balancín de apoyo central ballesta
Манкай де Мола • Седло пружины

Application	Description	Details	Ref.	Erqo No.
BM 395, 624/625, 659	<ul style="list-style-type: none"> EN Spring saddle DE Federwiege FR Boîtier de bogie ES Sillín de ballesta PT Assento mola apoio RU Поддрессоренная люлька 		624 325 0112	02.20906 

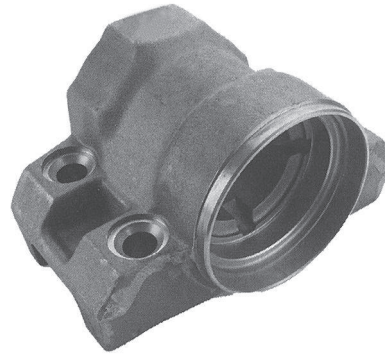

BM 385, 619, 624 (6x6), 623/625, 653/658	<ul style="list-style-type: none"> EN Spring bracket DE Federhalter FR Support de ressort ES Soporte de Ballesta PT Suporte feixe mola RU Кронштейн рессоры 		383 325 0112	02.20904 
---	---	--	--------------	---





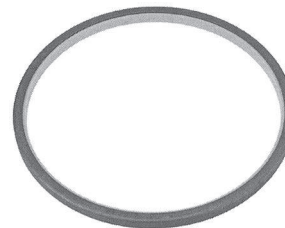











BM 395 BM 624/625/649/659	<ul style="list-style-type: none"> EN Oil seal DE Wellendichtring FR Joint speed ES Anillo retén PT Anel RU Сальник, 	200 x 218 x 10	395 320 0067	02.20832 
------------------------------------	--	----------------	--------------	---

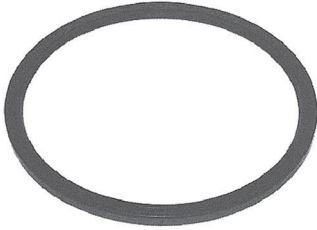

BM 395 BM 624/625/649/659	<ul style="list-style-type: none"> EN Seal ring DE O-Ring FR Joint torique ES Junta tórica PT Anel vedação caneca reduzida RU Уплотнительное кольцо 	114,0 x 5,6 mm	007 997 6048	02.22711 
------------------------------------	---	----------------	--------------	---

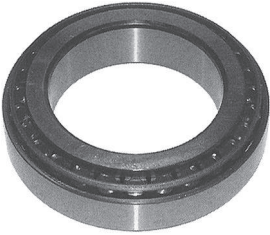

Application	Description	Details	Ref.	Erqo No.
BM 395/624/625/649, 659	<ul style="list-style-type: none"> EN O-ring DE O-Ring FR Joint torique ES Junta tórica PT Anel-o RU Уплотнительное кольцо 	139,2 x 5,7 mm	007 997 5948	02.22710 
4 BM 395, 624/625, 649, 659	<ul style="list-style-type: none"> EN Thrust washer DE Druckscheibe FR Rondelle de calage ES Disco de presión PT Arruela encosto RU Упорная шайба 		389 325 1062	02.20929 
BM 393, 619, 623/625, 624 (6x6), 653/658	<ul style="list-style-type: none"> EN Thrust washer DE Druckscheibe FR Rondelle de calage ES Arandela PT Arruela encosto RU Упорная шайба 		387 325 0162	02.20928 
BM 395, BM 624/625/649/659	<ul style="list-style-type: none"> EN Oil seal DE Wellendichtring FR Joint speed ES Anillo retén PT Retentor RU Сальник 	170 x 190 x 8 / 9	005 997 8447	02.22658 
BM 395, BM 624/625/659 428	<ul style="list-style-type: none"> EN Oil seal DE Wellendichtring FR Joint speed ES Anillo retén PT Retentor RU Сальник 	170 x 190 x 8,5	009 997 8846	02.22634 

Application	Description	Details	Ref.	Erqo No.
BM 385/393, BM 619/623/624/625, 653/658	EN Seal ring DE Dichtring FR Bague d'étanchéité ES Retén PT Anel RU Уплотнительное кольцо	143 x 165 x 8,5 /9,5	011 997 3746	02.22642 
				Sample
BM 395/624/625/649, 659	EN Tapered roller bearing DE Kegelrollenlager FR Roulement à rouleaux coniques ES Rodamiento de rodillos cónicos PT Rolamento eixo RU Конический роликоподшипник	repl. FAG 529065	003 981 6805	02.22334 
				4
BM 395/624/625/649, 659	EN Tapered roller bearing DE Kegelrollenlager FR Roulement à rouleaux coniques ES Rodamiento de rodillos cónicos PT Rolamento eixo RU Роликоподшипник	repl. FAG 32022X	002 981 5305	02.22331 
				
BM 385/393/619/623, 624/625/648/653, 658	EN Tapered roller bearing DE Kegelrollenlager FR Roulement à rouleaux coniques ES Rodamiento de rodillos cónicos PT Rolamento eixo RU Роликоподшипник	repl. FAG 32018X	004 981 4305	02.22338 
				
BM 385/393/619/623, 624/625/648/653, 658	EN Tapered roller bearing DE Kegelrollenlager FR Roulement à rouleaux coniques ES Rodamiento de rodillos cónicos PT Rolamento eixo RU Роликоподшипник	repl. FAG 529065	004 981 1805	02.22337 
				Sample







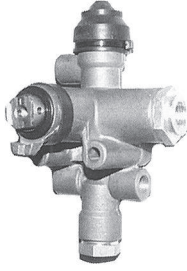

THE ORIGINAL NUMBERS OF THE VEHICLE MANUFACTURER MAY BE USED FOR COMPARISON PURPOSES ONLY AND MUST NOT BE MENTIONED ON INVOICES TO VEHICLE OWNERS.

Application	Description	Details	Ref.	Erqo No.
BM 395, 624/625, 649, 659	<ul style="list-style-type: none"> EN Spacer washer DE Abstandscheibe FR Entretoise ES Arandela distanciadora PT Porga espaçadora RU Дистанционная шайба 	M 80 x 2	389 325 2152	02.20926 
4 BM 385, 393, 623/625, 624 (6x6), 648, 653/658	<ul style="list-style-type: none"> EN Spacer washer DE Abstandscheibe FR Rondelle entretoise ES Arandela distanciadora PT Porga espaçadora RU Дистанционная шайба 		393 325 0052	02.20927 
BM 395, 624/625, 649, 659	<ul style="list-style-type: none"> EN Nut DE Mutter FR Ecrou ES Tuercas PT Porga RU Гайка 	M 80 x 2	389 990 5060	02.22479 
BM 385, 393, 623/625, 624 (6x6), 648, 653/658	<ul style="list-style-type: none"> EN Nut DE Mutter FR Ecrou ES Tuercas PT Porga RU Гайка 	M 70 x 2	393 990 0060	02.22480 
BM 395, 624/625, 649, 659	<ul style="list-style-type: none"> EN Gasket DE Dichtung FR Joint ES Junta PT Junta RU Уплотнение 		389 325 0280	02.20934 

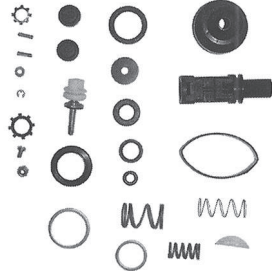
THE ORIGINAL NUMBERS OF THE VEHICLE MANUFACTURER MAY BE USED FOR COMPARISON PURPOSES ONLY AND MUST NOT BE MENTIONED ON INVOICES TO VEHICLE OWNERS.

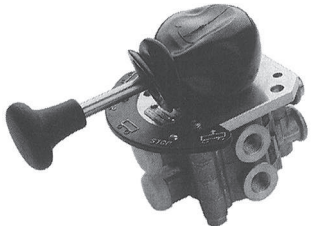
Application	Description	Details	Ref.	Erqo No.
BM 385, 393, 624/625, 648, 653/658	<ul style="list-style-type: none"> EN Gasket DE Dichtung FR Joint ES Junta PT Junta RU Уплотнение 		383 325 0080	02.20933 
BM 395, 624/625, 649, 659	<ul style="list-style-type: none"> EN Cover, spring saddle DE Abdeckung, Federwiege FR Couvercle, boîtier de bogie ES Cubierta, Resorte elástico PT Tampa, mancai de mola RU Колпак ступицы, Подрессоренная люлька 		389 320 0684	02.20834 
BM 385, 393, 619, 623/625, 624 (6x6), 648, 653/658	<ul style="list-style-type: none"> EN Cover DE Abdeckung FR Couvercle ES Tapa PT Tampa RU Колпак 		383 320 0084	02.20833 
NG/MK/SK	<ul style="list-style-type: none"> EN Screw DE Schraube FR Vis ES Tornillo PT Parafuso RU Болт 	M 8 x 18	000933 008145	02.22823 
OM 401/421/441 + A/LA, OM 402/422/442 + A/LA, OM 403/423/443 + A/LA	<ul style="list-style-type: none"> EN Drain plug DE Verschlusschraube FR Bouchon de vidange ES Tapón roscado PT Vujão RU Резьбовая пробка 	M 14 x 1,5	007604 014110	02.22884 
NG/MK/SK				

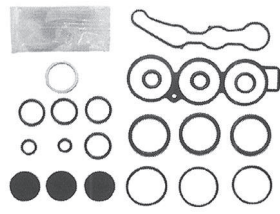
THE ORIGINAL NUMBERS OF THE VEHICLE MANUFACTURER MAY BE USED FOR COMPARISON PURPOSES ONLY AND MUST NOT BE MENTIONED ON INVOICES TO VEHICLE OWNERS.

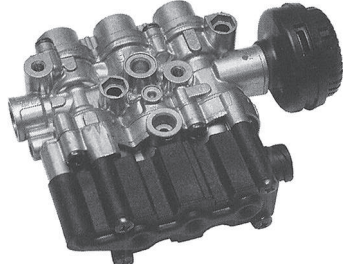
Application	Description	Details	Ref.	Erqo No.
MK/SK	<ul style="list-style-type: none"> EN Level valve DE Niveauventil FR Valve ES Válvula niveladora PT Válvula nível RU Клапан уровня 	repl. Knorr SV1280	000 328 3230	02.20984 
				
MK/SK	<ul style="list-style-type: none"> EN Repair kit DE Reparatursatz FR Kit de réparation ES Kit de reparación PT Jogo reparo RU Ремонтный комплект 	repl. Knorr I74651	000 320 1067	02.20831 
				
NG, MK (L/LS)	<ul style="list-style-type: none"> EN Level valve DE Niveauventil FR Valve ES Válvula niveladora PT Válvula nível RU Клапан уровня 	repl. Knorr SV3111 / Wabco 463 032 020	000 329 0825	02.20985 
				
MK/SK	<ul style="list-style-type: none"> EN Repair kit DE Reparatursatz FR Kit de réparation ES Kit de reparación PT Jogo reparo RU Ремонтный комплект 	repl. Wabco 472 900 009 2	000 420 7355	02.21238 
				
BM 652/655/656	<ul style="list-style-type: none"> EN Solenoid valve DE Magnetventil FR Electro-valve ES Válvula magnética PT Válvula solenóide RU Электромагнитный клапан 	repl. Wabco 472 900 053 0	000 327 6725	02.20980 
				

THE ORIGINAL NUMBERS OF THE VEHICLE MANUFACTURER MAY BE USED FOR COMPARISON PURPOSES ONLY AND MUST NOT BE MENTIONED ON INVOICES TO VEHICLE OWNERS.

Level ValveNiveauventil • Valves Niveau • Válvula Niveladora
Válvula de Nivel • Уровневый клапан

Application	Description	Details	Ref.	Erqo No.
BM 619, 623/624/625, 648, 650/651/652/653, 654/655/657/658, 659	<ul style="list-style-type: none"> EN Valve DE Ventil FR Soupape ES Válvula PT Válvula RU Клапан 		001 260 4957	02.20476 



NG/MK/SK

- EN Double check valve
- DE Doppelprüfventil
- FR Valve de frein
- ES Válvula antirretorno bidireccional
- PT Válvula bidireccional
- RU Двойной контрольный клапан



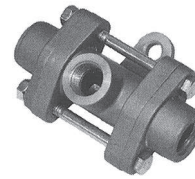

repl. Wabco 434 208 009 0

**02.23194**

4



Reaction Rod & V-Stay

Achsstrebe & V-Strebe • Barre de Réaction & Stabilisateur en V • Tirante/Barra de Reacción & Tirante en V
Barra de Reação & Barra-V • Стойка оси и V - образная тяга

Application	Description	Details	Ref.	Erqo No.
BM 395	<ul style="list-style-type: none"> EN Reaction rod DE Achsstrebe FR Barre de réaction ES Barra de reacción PT Haste reação RU Стойка оси 	638 mm	395 320 1432	02.20818 
4 BM 393/395/397, BM 623/624/625/658	<ul style="list-style-type: none"> EN Reaction rod DE Achsstrebe FR Barre de réaction ES Barra de reacción PT Haste reação RU Стойка оси 	585 mm	659 350 2706	02.21084 
BM 395, BM 624/625/649/659	<ul style="list-style-type: none"> EN Reaction rod DE Achsstrebe FR Barre de réaction ES Barra de reacción PT Haste reação RU Стойка оси 	579 mm	659 350 1206	02.21082 
BM 620/621/622/645, 646/647/655/656, 657/658	<ul style="list-style-type: none"> EN Reaction rod DE Achsstrebe FR Barre de réaction ES Barra de reacción PT Haste reação RU Стойка оси 	595 mm	655 350 0306	02.21077 
BM 395, BM 624/625/659	<ul style="list-style-type: none"> EN Reaction rod DE Achsstrebe FR Barre de réaction ES Barra de reacción PT Haste reação RU Стойка оси 	579 mm	659 350 3406	02.21086 

THE ORIGINAL NUMBERS OF THE VEHICLE MANUFACTURER MAY BE USED FOR COMPARISON PURPOSES ONLY AND MUST NOT BE MENTIONED ON INVOICES TO VEHICLE OWNERS.







Reaction Rod & V-StayAchsstrebe & V-Strebe • Barre de Réaction & Stabilisateur en V • Tirante/Barra de Reacción & Tirante en V
Barra de Reação & Barra-V • Стойка оси и V - образная тяга

Application	Description	Details	Ref.	Erqo No.
BM 395 BM 619/623/625/648, 653/658	<ul style="list-style-type: none"> EN Reaction rod DE Achsstrebe FR Barre de réaction ES Barra de reacción PT Haste reação RU Стойка оси 	585 mm	659 350 0106	02.21078 
BM 381/383/385 BM 616/617/619/651, 652/653/655	<ul style="list-style-type: none"> EN Reaction rod DE Achsstrebe FR Barre de réaction ES Barra de reacción PT Haste reação RU Стойка оси 	522 mm	652 350 0306	02.21073 
BM 625	<ul style="list-style-type: none"> EN Reaction rod DE Achsstrebe FR Barre de réaction ES Barra de reacción PT Haste reação RU Стойка оси 	635 mm	659 350 3206	02.21085 
BM 654	<ul style="list-style-type: none"> EN Reaction rod DE Achsstrebe FR Barre de réaction ES Barra de reacción PT Haste reação RU Стойка оси 	652 mm	654 350 0506	02.21076 



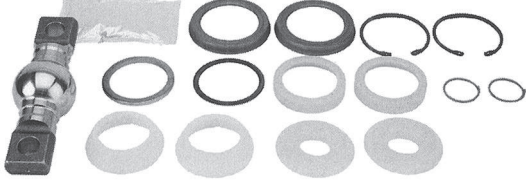

Sample

Reaction Rod & V-Stay

Achsstrebe & V-Strebe • Barre de Réaction & Stabilisateur en V • Tirante/Barra de Reacción & Tirante en V
 Barra de Reação & Barra-V • Стойка оси и V - образная тяга





Application	Description	Details	Ref.	Erqo No.
BM 617/622/652/653, 654	<ul style="list-style-type: none"> EN V-stay DE V-Strebe FR Stabilisateur en V ES Tirante en V PT Barra-V RU V - образная стойка оси 	623 mm	654 350 0105	02.21063 
				
BM 617/622/652/653, 654	<ul style="list-style-type: none"> EN Repair kit DE Reparatursatz FR Kit de réparation ES Kit de reparación PT Jogo reparo RU Ремонтный комплект 		000 350 0213	02.21089 
				
BM 652/653/654/655, 656/657/658	<ul style="list-style-type: none"> EN Repair kit DE Reparatursatz FR Collection reparation ES Juego de reparación PT Jogo reparo RU Ремонтный комплект 	Ø 85 mm / 142 mm / 22 mm	000 350 1805	02.21062 
				
BM 395, BM 623/624/625/649, 659	<ul style="list-style-type: none"> EN Repair kit DE Reparatursatz FR Kit de réparation ES Kit de reparación PT Jogo reparo RU Ремонтный комплект 	Ø 95 mm / 152 mm / 21 mm	000 350 0413	02.21090 
				





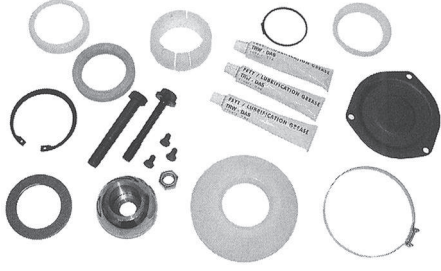

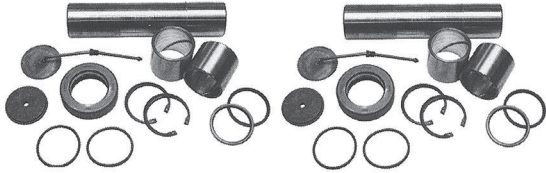

THE ORIGINAL NUMBERS OF THE VEHICLE MANUFACTURER MAY BE USED FOR COMPARISON PURPOSES ONLY AND MUST NOT BE MENTIONED ON INVOICES TO VEHICLE OWNERS.

Application	Description	Details	Ref.	Erqo No.
BM 625	<ul style="list-style-type: none"> EN Repair kit DE Reparatursatz FR Kit de réparation ES Kit de reparación PT Jogo reparo RU Ремонтный комплект 	Ø 108 mm / 152 mm / 21 mm	000 350 0113	02.21088 
BM 385/395, BM 616/619/623/624, 625/648/649/651, 652/653/654/655, 656/657/658/659	<ul style="list-style-type: none"> EN Repair kit DE Reparatursatz FR Kit de réparation ES Kit de reparación PT Jogo reparo RU Ремонтный комплект 	Ø 85 mm / 152 mm / 21 mm	000 350 0613	02.21091 
BM 381/383/385, BM 616/617/619/651, 652/653/654	<ul style="list-style-type: none"> EN Repair kit DE Reparatursatz FR Kit de réparation ES Kit de reparación PT Jogo reparo RU Ремонтный комплект 		000 350 0205	02.21057 
BM 616/617/619/620, 621/622/623/645, 646/647/648/655, 656/657/658	<ul style="list-style-type: none"> EN Repair kit DE Reparatursatz FR Kit de réparation ES Kit de reparación PT Jogo reparo RU Ремонтный комплект 		000 586 1533	02.22081 
BM 381/383/385/387, 389/397, BM 616/617/619/620, 621/622/623/625, 645/646/647/648, 655/656/657/658	<ul style="list-style-type: none"> EN Repair kit DE Reparatursatz FR Kit de réparation ES Kit de reparación PT Jogo reparo RU Ремонтный комплект 		000 586 1433	02.22080 

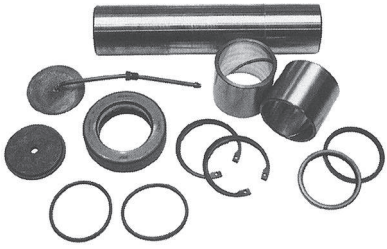

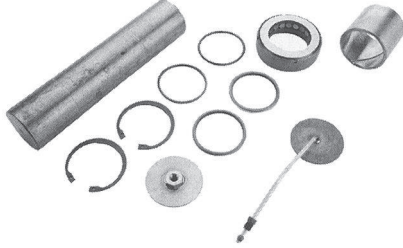



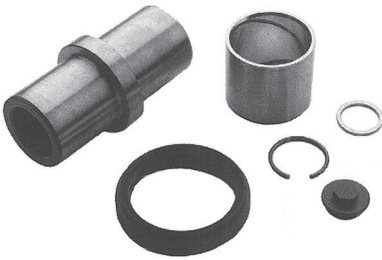

Reaction Rod & V-Stay

Achsstrebe & V-Strebe • Barre de Réaction & Stabilisateur en V • Tirante/Barra de Reacción & Tirante en V
 Barra de Reação & Barra-V • Стойка оси и V - образная тяга







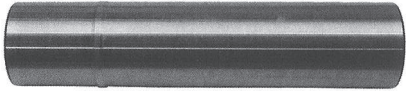

Application	Description	Details	Ref.	Erqo No.
BM 381/383/385/387, 389/393 BM 616/617/619/620, 621/622/623/645, 646/647/648/655, 656/657/658	EN Repair kit DE Reparatursatz FR Kit de réparation ES Kit de reparación PT Jogo reparo RU Ремонтный комплект		000 350 0405	02.21059 
4 BM 651/652/653/654, 655/656/657/658	EN Repair kit, v-stay DE Reparatursatz, V-Strebe FR Kit de réparation, stabilisateur en V ES Kit de reparación, Tirante en V PT Jogo reparo, barra-v RU Ремонтный комплект, V - образная стойка оси		000 350 1705	02.21061 

Application	Description	Details	Ref.	Erqo No.
VL 4 /... (BM 733/739)	<ul style="list-style-type: none"> EN King pin kit, double kit DE Achsschenkelbolzensatz, Doppelsatz FR Kit pivot, double kit ES Juego King Pin, Juego doble PT Jogo pino mestre, duplo RU Комплект шкворней, двойной комплект 		391 330 0019 S	02.23195 
VL 4 /... (BM 733/739)	<ul style="list-style-type: none"> EN King pin kit DE Achsschenkelbolzensatz FR Kit pivot ES Juego King Pin PT Jogo pino mestre RU Комплект шкворней 		391 330 0019	02.21002 
VL 4 /... (BM 733/739)	<ul style="list-style-type: none"> EN King pin kit 1 st oversize DE Achsschenkelbolzensatz 1. Übergröße FR Kit de pivot 1er surdimensionné ES Juego de pivotes de mangueta, King pin 1° extragrandes PT Jogo pino mestre 1° extra grande RU Комплект шкворней 1. негабарит 		391 330 0119	02.21003 
AL 7 /... (BM 730/731)	<ul style="list-style-type: none"> EN King pin kit upper DE Achsschenkelbolzensatz oben FR Kit de pivot supérieur ES Juego de pivotes de mangueta, King pin superior PT Jogo pino mestre superior RU Комплект шкворней верхняя 		346 330 0019	02.20998 

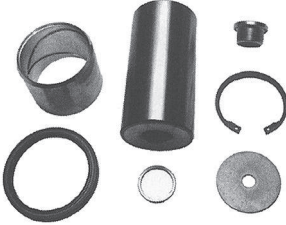





THE ORIGINAL NUMBERS OF THE VEHICLE MANUFACTURER MAY BE USED FOR COMPARISON PURPOSES ONLY AND MUST NOT BE MENTIONED ON INVOICES TO VEHICLE OWNERS.



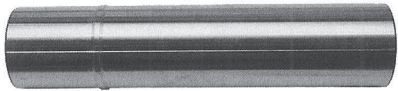

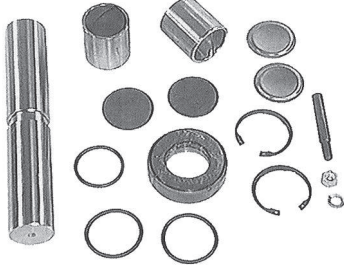





Application	Description	Details	Ref.	Erqo No.
AL 7/... (BM 730/731) --axle V492663, axle 004323--	<ul style="list-style-type: none"> EN King pin kit lower DE Achsschenkelbolzensatz unten FR Kit de pivot Inférieur ES Juego de pivotes de mangueta, King pin inferior PT Jogo pino mestre inferior RU Комплект шкворней нижн. 		346 330 0119	02.20999 
AL 7/... (BM 730/731) axle V492664--	<ul style="list-style-type: none"> EN King pin kit lower DE Achsschenkelbolzensatz unten FR Kit de pivot inférieur ES Juego de pivotes de mangueta, King pin inferior PT Jogo pino mestre inferior RU Комплект шкворней нижн. 		346 330 0219	02.21000 
VL 4/... (BM 739)	<ul style="list-style-type: none"> EN King pin kit DE Achsschenkelbolzensatz FR Kit de pivot ES Juego de pivotes de mangueta, King pin PT Jogo pino mestre RU Комплект шкворней 		655 330 0019	02.21006 
VL 4/... (BM 739)	<ul style="list-style-type: none"> EN King pin kit DE Achsschenkelbolzensatz FR Kit de pivot ES Juego de pivotes de mangueta, King pin PT Jogo pino mestre RU Комплект шкворней 		655 330 0119	02.21007 

THE ORIGINAL NUMBERS OF THE VEHICLE MANUFACTURER MAY BE USED FOR COMPARISON PURPOSES ONLY AND MUST NOT BE MENTIONED ON INVOICES TO VEHICLE OWNERS.

Application	Description	Details	Ref.	Erqo No.
VL4/... (BM 739)	<ul style="list-style-type: none"> EN King pin DE Achsschenkelbolzen FR Axe de pivot ES Pivote de mangueta PT Pino manga eixo RU Шкворень поворотного кулака 	Ø 50 mm	942 332 0006	02.21034 
				
AL7/...; AD 7/... (BM 730/731)	<ul style="list-style-type: none"> EN King pin kit upper DE Achsschenkelbolzensatz oben FR Kit de pivot supérieur ES Juego de pivotes de mangueta superior PT Jogo pino mestre superior RU Комплект шкворней верхняя 		625 330 0119	02.21004 
				
AL7/...; AD 7/... (BM 730/731)	<ul style="list-style-type: none"> EN King pin kit lower DE Achsschenkelbolzensatz unten FR Kit de pivot inférieur ES Juego de pivotes de mangueta inferior PT Jogo pino mestre inferior RU Комплект шкворней нижн. 		625 330 0419	02.21005 
				
VL 5/... (BM 739)	<ul style="list-style-type: none"> EN King pin kit DE Achsschenkelbolzensatz FR Kit de pivot ES Juego de pivotes de mangueta, King pin PT Jogo pino mestre RU Комплект шкворней 		942 330 0219	02.21008 
				
VL 5/... (BM 739)	<ul style="list-style-type: none"> EN King pin kit DE Achsschenkelbolzensatz FR Kit de pivot ES Juego de pivotes de mangueta, King pin PT Jogo pino mestre RU Комплект шкворней 		942 330 0319	02.21009 
				









THE ORIGINAL NUMBERS OF THE VEHICLE MANUFACTURER MAY BE USED FOR COMPARISON PURPOSES ONLY AND MUST NOT BE MENTIONED ON INVOICES TO VEHICLE OWNERS.

Application	Description	Details	Ref.	Erqo No.
VL 5/... (BM 739)	<ul style="list-style-type: none"> EN King pin DE Achsschenkelbolzen FR Axe de pivot ES Pivote de mangueta PT Pino manga eixo RU Шкворень поворотного кулака 		942 332 0806	02.21035 
				
VL 3 /... (BM 730)	<ul style="list-style-type: none"> EN King pin kit DE Achsschenkelbolzensatz FR Kit de pivot ES Juego de pivotes de mangueta, King pin PT Jogo pino mestre RU Комплект шкворней 		360 330 0719	02.21001 
				
AL 7 / A D 7 /... (BM 730/731)	<ul style="list-style-type: none"> EN Spacer ring, king pin DE Abstandring, Achsschenkel FR Entretoise, Fusée ES Anillo distanciador, Mangueta PT Espaçador flange, pino mestre RU Распорное кольцо, Поворотная цапфа 		346 332 0151	02.21036 
				
VL 3/... (BM730/732), VL 41... (BM733/739)	<ul style="list-style-type: none"> EN Pressure screw DE Druckschraube FR Vis de serrage ES Tornillo de presión PT Parafuso pressão com porca RU Нажимной болт с гайкой 	M 16 x 1,5	387 332 0271	02.21040 
				







Application	Description	Details	Ref.	Erqo No.
V 733/739/749	EN Drag link DE Lenkstange FR Barre de direction ES Barra de dirección PT Barra direção RU Рулевая тяга	1620 mm	393 330 0303	02.20989 
				
V 739	EN Drag link DE Lenkstange FR Barre de direction ES Barra de dirección PT Barra direção RU Рулевая тяга	1625 mm	949 330 0903	02.20997 
				
V 730/732/733/739	EN Ball joint, left hand thread DE Kuglgelenk, Linksgewinde FR Rotule, filetage à gauche ES Rótula, rosca izquierda PT Articulação alavanca, rosca esquerda RU Шариковый шарнир, Левая резьба	C:26/TH:M30x1,5L/L:115	302 330 0235	02.21020 
				
V 730/731/732/733, 739 BM 381/383	EN Ball joint, right hand thread DE Kuglgelenk, Rechtsgewinde FR Rotule, filetage à droite ES Rótula, rosca derecha PT Articulação alavanca, rosca direita RU Шариковый шарнир, Правая резьба	C:26/TH:M30x1,5R/L:115	001 330 0135	02.21013 
				
V 730/733/739 BM 385/391, BM 619/625/647/652, 654/657	EN Ball joint, left hand thread DE Kuglgelenk, Linksgewinde FR Rotule, filetage à gauche ES Rótula, rosca izquierda PT Articulação alavanca, rosca esquerda RU Шариковый шарнир, Левая резьба	C:30/TH:M30x1,5 L; L120	000 460 3548	02.21589 
				

THE ORIGINAL NUMBERS OF THE VEHICLE MANUFACTURER MAY BE USED FOR COMPARISON PURPOSES ONLY AND MUST NOT BE MENTIONED ON INVOICES TO VEHICLE OWNERS.

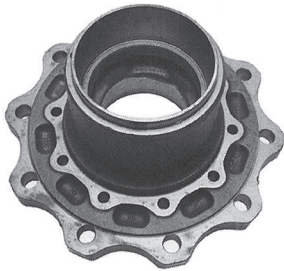

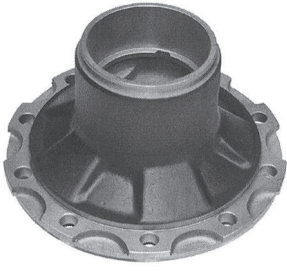

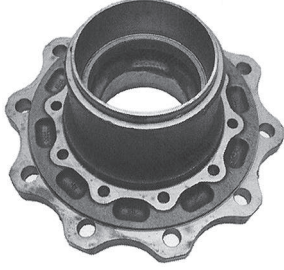



Application	Description	Details	Ref.	Erqo No.
V 730/731/733/739 BM 385/389/391/393, 397, BM 616/617/619/620, 621/622/623/624, 625/645/646/647, 648/649/652/653, 654/655/656/657, 658/659	<ul style="list-style-type: none"> EN Ball joint, right hand thread DE Kugelgelenk, Rechtsgewinde FR Rotule, filetage à droite ES Rótula, rosca derecha PT Articulação alavanca, rosca direita RU Шариковый шарнир, Правая резьба 	C:30/TH:M30x1,5R/L:120	000 460 2948	02.21585 
V 739, H 749, BM 625	<ul style="list-style-type: none"> EN Ball joint, left hand thread DE Kugelkopf, Linksgewinde FR Rotule direction filetage à gauche ES Rótula, rosca izquierda PT Articulação alavanca, rosca esquerda RU Шаровая головка, Левая резьба 	C:32/TH:M30x1,5L/L:120	001 460 2548	02.21620 
V 730/731/739, H 749, BM 625	<ul style="list-style-type: none"> EN Ball joint DE Kugelkopf FR Rotule ES Rótula PT Articulação alavanca RU Шаровая головка 	C:32/TH:M30x1,5L/L:120	001 460 0548	02.21607 
V 730/731/733/739, BM 385/389/391/393, 397 BM 617/619/620/621, 622/623,625/645, 646/647/648/649, 651/652/653/654, 655/656/657/658, 659	<ul style="list-style-type: none"> EN Boot DE Manschette FR Manchon ES Retén PT Guarda-pó terminal barra direção curta RU Манжета 	23 / 50 mm	000 462 1796	02.21656 
V 730/731/739, H 749, BM 625, 652/653/655/656	<ul style="list-style-type: none"> EN Nut DE Mutter FR Ecrou ES Tuercas PT Porca RU Гайка 	M 27 x 1,5	001 990 7651	02.22473 

Application	Description	Details	Ref.	Erqo No.
AL 7 / A D 7 / ... (BM 730/731)	<ul style="list-style-type: none"> EN Repair kit king pin side DE Reparatursatz achsschenkelseitig FR Kit de réparation kit pivot ES Kit de reparación para el lado de la mangueta PT Jogo reparo pino mestre lateral RU Ремонтный комплект со стороны шкворня 		659 330 0251	02.21026 
AL 7 / ... , AD 7 / ... (BM 730/731)	<ul style="list-style-type: none"> EN Repair kit axle bridge side DE Reparatursatz achsbrückenseitig FR Kit de réparation moyeu avant ES Kit de reparación para el lado puente del eje PT Jogo reparo semi eixo lateral RU Ремонтный комплект со стороны балки моста 		659 330 0351	02.21027 
V 730/731	<ul style="list-style-type: none"> EN Needle bearing DE Nadellager FR Roulement à aiguilles ES Rodamiento de agujas PT Rolamento agulha RU Игольчатый подшипник 		004 981 6310	02.22361 
V 730/731, H 740/746/748	<ul style="list-style-type: none"> EN Oil seal DE Well lendichtring FR Joint speed ES Anillo retén PT Retentor RU Сальник 	72 x 105 x 19	020 997 0647	02.22697 
				



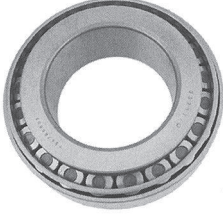

THE ORIGINAL NUMBERS OF THE VEHICLE MANUFACTURER MAY BE USED FOR COMPARISON PURPOSES ONLY AND MUST NOT BE MENTIONED ON INVOICES TO VEHICLE OWNERS.

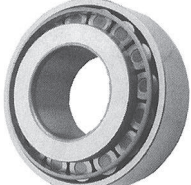
Application	Description	Details	Ref.	Erqo No.
VL 4 /...; VD 4 /... (BM 739)	<ul style="list-style-type: none"> EN Wheel hub front axle DE Radnabe Vorderachse FR Moyeu de roue essieu avant ES Buje de rueda eje delantero PT Cubo roda eixo frente RU Ступица колеса передний мост 		623 334 0101	02.21044 
VL4/... (BM 733/739)	<ul style="list-style-type: none"> EN Wheel hub front axle DE Radnabe Vorderachse FR Moyeu de roue essieu avant ES Buje de rueda eje delantero PT Cubo roda eixo frente RU Ступица колеса передний мост 		624 334 0301	02.21045 
VL 4 /...; VD 4 /... (BM 733/739); NL 4 /...; NS 4 /... (BM 749)	<ul style="list-style-type: none"> EN Wheel hub DE Radnabe FR Moyeu de roue ES Buje de rueda PT Cubo roda RU Ступица колеса 		942 334 1201	02.21047 
730/732/733/739, 749	<ul style="list-style-type: none"> EN Tapered roller bearing DE Kegelrollenlager FR Roulement ES Rodamiento de rodillos cónicos PT Rolamento eixo RU Роликоподшипник 	repl. FAG 33210	002 981 7905	02.22332 

Sample

Application	Description	Details	Ref.	Erqo No.
730/732/733	<ul style="list-style-type: none"> EN Tapered roller bearing DE Kegelrollenlager FR Roulement à rouleaux coniques ES Rodamiento de rodillos cónicos PT Rolamento eixo RU Конический роликоподшипник 	repl. FAG: 33213	006 981 6305	02.22342 
				
733/739, 746/749	<ul style="list-style-type: none"> EN Tapered roller bearing DE Kegelrollenlager FR Roulement ES Rodamiento de rodillos cónicos PT Rolamento eixo RU Роликоподшипник 	repl. FAG 534565	005 981 3105	02.22339 
				
			Sample	
733/739, 746/749	<ul style="list-style-type: none"> EN Tapered roller bearing DE Kegelrollenlager FR Roulement ES Rodamiento de rodillos cónicos PT Rolamento eixo RU Конический роликоподшипник 	repl. FAG: 32310	001 981 7605	02.22330 
				
739, 749	<ul style="list-style-type: none"> EN Tapered roller bearing DE Kegelrollenlager FR Roulement ES Rodamiento de rodillos cónicos PT Rolamento eixo RU Конический роликоподшипник 	repl. FAG: 33217	007 981 7005	02.22344 
				
739, 749	<ul style="list-style-type: none"> EN Tapered roller bearing DE Kegelrollenlager FR Roulement ES Rodamiento de rodillos cónicos PT Rolamento eixo RU Конический роликоподшипник 	repl. FAG: 32311	006 981 0805	02.22341 
				







Application	Description	Details	Ref.	Erqo No.
H 747, V 730/731/733/737	<ul style="list-style-type: none"> EN Oil seal DE Wellendichtring FR Joint speed ES Anillo retén PT Retentor RU Сальник 	160 x 180 x 10	015 997 5847	02.22687 
V 730/731/733/737, H 747/748	<ul style="list-style-type: none"> EN Oil seal DE Wellendichtring FR Joint speed ES Anillo retén PT Retentor RU Сальник 	160 x 180 x 10	015 997 5747	02.22686 
V 730/732/733 H 749	<ul style="list-style-type: none"> EN Oil seal DE Wellendichtring FR Joint speed ES Anillo retén PT Retentor RU Сальник 	100 x 120 x 13	007 997 3646	02.22630 
V 733/739, H 749	<ul style="list-style-type: none"> EN Oil seal DE Wellendichtring FR Joint speed ES Anillo retén PT Retentor RU Сальник 	100 x 130 x 13	009 997 6747	02.22666 
V 733/739, H 746/749	<ul style="list-style-type: none"> EN Oil seal DE Wellendichtring FR Joint speed ES Anillo retén PT Retentor RU Сальник 	70 x 81,5 x 6	002 997 6547	02.22650 

Application	Description	Details	Ref.	Erqo No.
V 733/739	<ul style="list-style-type: none"> EN Oil seal DE Wellendichtring FR Joint speed ES Anillo retén PT Retentor RU Сальник 	120 x 150 x 15 / 12	004 997 1847	02.22653 
V 733/739 H 749	<ul style="list-style-type: none"> EN Oil seal DE Wellendichtring FR Joint speed ES Anillo retén PT Retentor RU Сальник 	120 x 150 x 15 / 20,2	013 997 7346	02.22647 
VL 5 / ... (BM 739,400-442); HL 4 / ... (BM 744); HL 5 / ... (BM 745)	<ul style="list-style-type: none"> EN Repair kit DE Reparatursatz FR Kit de réparation ES Kit de reparación PT Jogo reparo RU Ремонтный комплект 		385 350 0268	02.21099 
730/731/733 748	<ul style="list-style-type: none"> EN O-ring DE O-Ring FR Joint torique ES Junta tórica PT Anel RU Уплотнительное кольцо 	269,0 x 6,0 mm	494 334 0059	02.21052 
VL 3 / ... (BM 730)	<ul style="list-style-type: none"> EN Ring, left DE Ring, links FR Bague, gauche ES Anillo, izquierdo PT Anel, esquerdo RU Кольцо, лев. 		360 334 0115	02.21048 

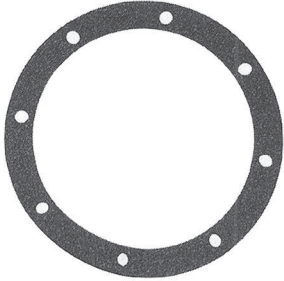

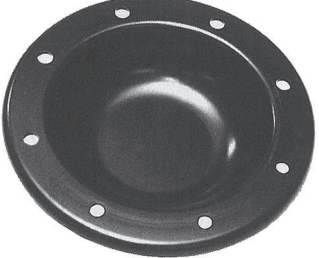

Application	Description	Details	Ref.	Erqo No.
VL 3 /... (B M 730)	<ul style="list-style-type: none"> EN Ring, right DE Ring, rechts FR Bague, droite ES Anillo, derecho PT Anel, direito RU Кольцо, прав. 		360 334 0215	02.21049 
VL 4 /... (BM 733/739)	<ul style="list-style-type: none"> EN Ring DE Ring FR Bague ES Anillo PT Anel RU Кольцо 		389 334 0215	02.21050 
VL 3 /... (BM 730/732/733)	<ul style="list-style-type: none"> EN Thrust washer DE Druckscheibe FR Rondelle de calage ES Arandela PT Arruela encosto RU Упорная шайба 		355 332 0062	02.21037 
VL 4 / V D 4 /... (BM 739)	<ul style="list-style-type: none"> EN Thrust washer DE Druckscheibe FR Rondelle de calage ES Disco de presión PT Arruela encosto RU Упорная шайба 	50 x 107 x 6 mm 	386 332 0062	02.21038 
VL 5 /... (BM 739)	<ul style="list-style-type: none"> EN Thrust washer DE Druckscheibe FR Rondelle de calage ES Arandela de presión PT Arruela encosto RU Упорная шайба 		656 332 0062	02.21039 

THE ORIGINAL NUMBERS OF THE VEHICLE MANUFACTURER MAY BE USED FOR COMPARISON PURPOSES ONLY AND MUST NOT BE MENTIONED ON INVOICES TO VEHICLE OWNERS.







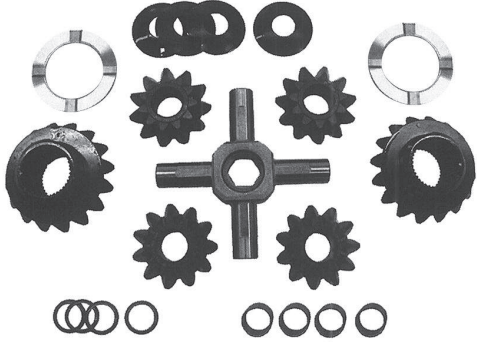

Application	Description	Details	Ref.	Erqo No.
VL 3/... (BM 730/732/733)	<ul style="list-style-type: none"> EN Nut DE Mutter FR Ecrou ES Tuerca PT Porca RU Гайка 	M 39 x 1,5	360 332 0372	02.21041 
				
VL 3/... (BM 730/732), VL4/... (BM 733/739)	<ul style="list-style-type: none"> EN Nut DE Mutter FR Ecrou ES Tuerca PT Porca RU Гайка 	M 40 x 1,5	652 330 0088	02.21029 
				
VL 4/... (BM 733/739)	<ul style="list-style-type: none"> EN Nut DE Mutter FR Ecrou ES Tuerca PT Porca RU Гайка 	M 45 x 1,5	656 330 0088	02.21030 
				
VL3/... (BM 730/733), VL4/... (BM 739)	<ul style="list-style-type: none"> EN Screw DE Schraube FR Vis ES Tornillo PT Parafuso RU Болт 	M 10 x 1,5 x 40		
				
VL 3 /... (BM 730/732/733)	<ul style="list-style-type: none"> EN Lock DE Sicherung FR Arrêtoir ES Seguro PT Trava RU Предохранитель 		355 332 0273	02.21043 
				
VL 4 /... (BM 739)	<ul style="list-style-type: none"> EN Gasket DE Dichtung FR Joint ES Junta PT Junta RU Уплотнение 		389 334 0080	02.21053 
				

Application	Description	Details	Ref.	Erqo No.
VL 5 / ... (BM 739)	<ul style="list-style-type: none"> EN Gasket DE Dichtung FR Joint ES Junta PT Junta RU Уплотнение 		943 334 0080	02.21054 
VL 4 / ... (BM 739)	<ul style="list-style-type: none"> EN Hub cap DE Nabendeckel FR Bouchon de pignon ES Taracubo PT Calota cubo RU Колпак ступицы 		389 334 0025	02.21051 
VL 5 / ... (BM 739)	<ul style="list-style-type: none"> EN Hub cap DE Nabendeckel FR Bouchon de pignon ES Taracubo PT Calota cubo RU Колпак ступицы 		327 356 0120	02.21129 

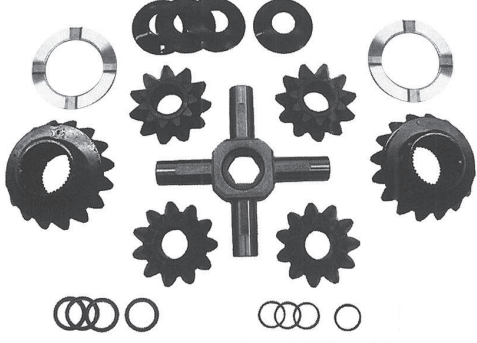

5

Application	Description	Details	Ref.	Erqo No.
V 730/731, H 740/746/748	<ul style="list-style-type: none"> EN Screw DE Schraube FR Vis ES Tornillo PT Parafuso RU Болт 	M 12 x 1,5 x 40	355 990 0604	02.22437 
				
H 740,748	<ul style="list-style-type: none"> EN Bolt DE Bolzen FR Axe ES Tornillo PT Perno RU Болт 	M 12 x 1,5 x 85	355 990 1804	02.22439 
				
V 730/731, H 740/746/748	<ul style="list-style-type: none"> EN Seal ring holder DE Dichtringhalter FR Joint raccord ES Soporte de anillo obturador PT Suporte anel vedador eixo traseiro RU Кронштейн 		355 353 0158	02.21117 
				
H 740/746/748	<ul style="list-style-type: none"> EN Seal ring holder DE Dichtringhalter FR Joint raccord ES Soporte de anillo obturador PT Suporte anel vedador eixo traseiro RU Кронштейн 		942 353 0117	02.21111 
				

THE ORIGINAL NUMBERS OF THE VEHICLE MANUFACTURER MAY BE USED FOR COMPARISON PURPOSES ONLY AND MUST NOT BE MENTIONED ON INVOICES TO VEHICLE OWNERS.

Application	Description	Details	Ref.	Erqo No.
HL 7/...; HD 7 / ... (B M 740/746/748)	<ul style="list-style-type: none"> EN Repair kit, spider DE Reparatursatz, Ausgleichstern FR Kit de réparation, Etoile de différentiel ES Kit de reparación, Cruceta del diferencial PT Jogo engrenagem caixa satélite RU Ремонтный комплект, крестовины дифференциала 		387 350 0040	02.21096 
HL 7 / H D 7 /... (BM 740/748)	<ul style="list-style-type: none"> EN Repair kit, spider DE Reparatursatz, Ausgleichstern FR Kit de réparation, Etoile de différentiel ES Kit de reparación, Cruceta del diferencial PT Jogo engrenagem caixa satélite RU Ремонтный комплект, крестовины дифференциала 		395 350 0040	02.21097 
HL7/...; HD 7/... (BM 740/746/748)	<ul style="list-style-type: none"> EN Thrust washer DE Druckscheibe FR Rondelle de calage ES Arandela PT Arruela encosto RU Упорная шайба 		346 353 2262	02.21118 
HL 7/...; HD 7/... (BM 740/746/748)	<ul style="list-style-type: none"> EN Thrust washer DE Druckscheibe FR Rondelle de calage ES Arandela PT Arruela encosto RU Упорная шайба 		346 353 0124	02.21112 







THE ORIGINAL NUMBERS OF THE VEHICLE MANUFACTURER MAY BE USED FOR COMPARISON PURPOSES ONLY AND MUST NOT BE MENTIONED ON INVOICES TO VEHICLE OWNERS.

Application	Description	Details	Ref.	Erqo No.
HL 7/...; HD 7/... (BM 740/746/748)	<ul style="list-style-type: none"> EN Bushing DE Buchse FR Vague ES Casquillo PT Vucha RU Втулка 		346 353 0950	02.21115 
				
V 730/731, H 740/746/748	<ul style="list-style-type: none"> EN Oil seal DE Wellendichtring FR Joint speed ES Retén PT Retentor RU Сальник 	75 x 95 x 10	017 997 3047	02.22690 
				
H 740/748	<ul style="list-style-type: none"> EN Oil seal DE Wellendichtring FR Joint speed ES Retén PT Retentor RU Сальник 	75 x 95 x 10 / 9,5	017 997 3147	02.22691 
				
H 740/745/746/748	<ul style="list-style-type: none"> EN Oil seal DE Wellendichtring FR Joint speed ES Anillo retén PT Retentor RU Сальник 	85 x 145 x 12 / 37	015 997 4747	02.22684 
				
H 740/746/748	<ul style="list-style-type: none"> EN Oil seal DE Wellendichtring FR Joint speed ES Anillo retén PT Retentor RU Сальник 	75 x 95 x 12	008 997 2246	02.22631 
				

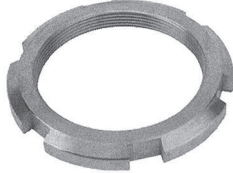





THE ORIGINAL NUMBERS OF THE VEHICLE MANUFACTURER MAY BE USED FOR COMPARISON PURPOSES ONLY AND MUST NOT BE MENTIONED ON INVOICES TO VEHICLE OWNERS.

Application	Description	Details	Ref.	Erqo No.
H 740/746/748	<ul style="list-style-type: none"> EN Oil seal DE Wellendichtring FR Joint speed ES Anillo retén PT Retentor RU Сальник 	85 x 105 x 13	009 997 1146	02.22632 
				Sample
HL 7/...; HD 7 / ... (BM 740/748)	<ul style="list-style-type: none"> EN Protecting cap DE Schutzkappe FR Bouchon de protection ES Caperuza de protección PT Capa proteção retentor RU Защитный колпачок 		346 353 0090	02.21121 
				
HL7/...; HD 7/... (BM 740/746/748)	<ul style="list-style-type: none"> EN Thread ring DE Gewinding FR Ecrou crénelé ES Anillo roscado PT Roscado RU Резьбовое кольцо 		652 353 0025	02.21113 
				
HD 7/... (BM 740.500-549)	<ul style="list-style-type: none"> EN Adjusting ring DE Einstellring FR Bague de réglage ES Anillo de ajuste PT Anel ajuste RU Установочное кольцо 		346 353 0725	02.23196 
				
H 740, 746, 748	<ul style="list-style-type: none"> EN Nut spider, rear axle DE Mutter Ausgleichstern, Hinterachse FR Ecrou Etoile de différentiel, essieu arrière ES Tuerca Cruceta del diferencial, eje trasero PT Porca engrenagem caixa satélite, eixo tr. RU Гайка крестовины дифференциала, з: 	M 60 x 1,5	346 353 0126	02.21114 
				

THE ORIGINAL NUMBERS OF THE VEHICLE MANUFACTURER MAY BE USED FOR COMPARISON PURPOSES ONLY AND MUST NOT BE MENTIONED ON INVOICES TO VEHICLE OWNERS.

Application	Description	Details	Ref.	Erqo No.
H 740, 742, 746, 748	<ul style="list-style-type: none"> EN Grooved nut DE Nutmutter FR Ecrou à gorge ES Tuerca ranurada PT Porca ranhurada RU Шлицевая гайка 	M 60 x 1,5	674 356 0226	02.21131 
				
V 731, 733, H 741, 742, 743, 744, 745, 746	<ul style="list-style-type: none"> EN Flat collar nut old version DE Flachbundmutter alte Ausführung FR Ecrou à embase ancien modèle ES Tuerca de collar plano version antigua PT Porca versão anterior RU Гайка с цилиндрическим пояском старое исполнение 	M 40 x 1,5	385 351 0072	02.21105 
				
V 731, 733, H 741, 742, 743, 744, 745, 746	<ul style="list-style-type: none"> EN Flat collar nut new version DE Flachbundmutter neue Ausführung FR Ecrou à embase nouveau modèle ES Tuerca de collar plano version nueva PT Porca cubo traseiro nova versão RU Гайка с цилиндрическим пояском нового типа 	M 40 x 1,5	385 351 0172	02.21106 
				
H 740, 741, 743, 744, 745, 746, 747, 748	<ul style="list-style-type: none"> EN Flat collar nut old version DE Flachbundmutter alte Ausführung FR Ecrou à embase ancien modèle ES Tuerca de collar plano version antigua PT Porca cubo traseiro versão anterior RU Гайка с цилиндрическим пояском старое исполнение 	M 45 x 1,5	366 353 0072	02.21120 
				

THE ORIGINAL NUMBERS OF THE VEHICLE MANUFACTURER MAY BE USED FOR COMPARISON PURPOSES ONLY AND MUST NOT BE MENTIONED ON INVOICES TO VEHICLE OWNERS.

Application	Description	Details	Ref.	Erqo No.
V 730, 731, H 740, 741, 743, 744, 745, 746, 747, 748	<p>EN Flat collar nut new version</p> <p>DE Flachbundmutter neue Ausführung</p> <p>FR Ecrou à embase nouveau modèle</p> <p>ES Tuerca de collar plano version nueva</p> <p>PT Porca cubo traseiro nova versão</p> <p>RU Гайка с цилиндрическим пояском новое исполнение</p>	M 45 x 1,5	385 351 0672	02.21108 
				
H 740, 748	<p>EN Flat collar nut old version</p> <p>DE Flachbundmutter alte Ausführung</p> <p>FR Ecrou à embase ancien modèle</p> <p>ES Tuerca de collar plano version antigua</p> <p>PT Porca cubo traseiro versão anterior</p> <p>RU Гайка с цилиндрическим пояском старое исполнение</p>	M 55 x 1,5	346 353 0072	02.23197 
				
V 730, H 740, 741, 746, 748	<p>EN Flat collar nut new version</p> <p>DE Flachbundmutter neue Ausführung</p> <p>FR Ecrou à embase nouveau modèle</p> <p>ES Tuerca de collar plano version actual</p> <p>PT Porca cubo traseiro nova versão</p> <p>RU новая версия новое исполнение</p>	M 55 x 1,5	946 351 0072	02.21109 
				

Application	Description	Details	Ref.	Erqo No.
HL 7 / ...; HD 7 / ... (BM 740/746/748)	<ul style="list-style-type: none"> EN Wheel hub rear axle DE Radnabe Hinterachse FR Moyeu de roue essieu arrière ES Buje de rueda eje trasero PT Cubo roda eixo traseiro RU Ступица колеса задней оси 		346 356 2401	02.21126 

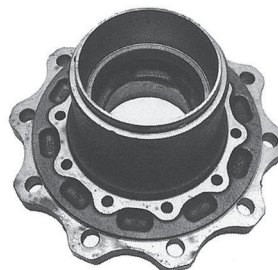

Sample

5

HL 7 / ... (BM 740/746/748)	<ul style="list-style-type: none"> EN Bell hub rear axle DE Glockennabe Hinterachse FR Moyeu a cloche essieu arrière ES Cubo de campana eje trasero PT Cubo eixo traseiro RU задняя ось задней оси 		346 350 1533	02.21092 
--------------------------------	--	--	--------------	--

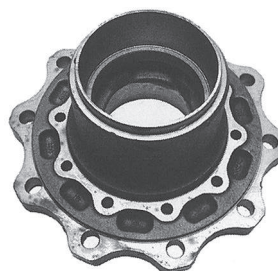



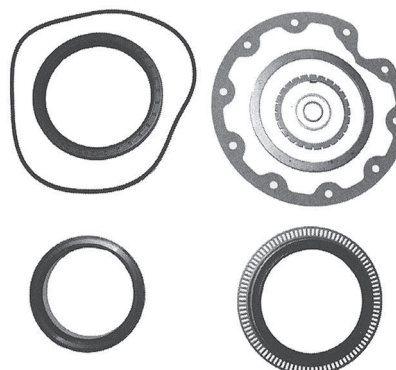

Sample

HL 7/...; HD II... (BM 740/746/748)	<ul style="list-style-type: none"> EN Repair kit, outer planetary axle DE Reparatursatz, Außenplanetenachse FR Kit de réparation, Essieu planétaire externe ES Kit de reparación, Eje de cubos reductores PT Jogo reparo, eixo planetário externo RU Ремонтный комплект 		940 350 0135	02.21094 
--	---	--	--------------	---







Application	Description	Details	Ref.	Erqo No.
HL II...; HD II ... (BM 740/746/748)	<ul style="list-style-type: none"> EN Repair kit, outer planetary axle DE Reparatursatz, Außenplanetenachse FR Kit de réparation, Essieu planétaire externe ES Kit de reparación, Eje de cubos reductores PT Jogo reparo, eixo planetário externo RU Ремонтный комплект 		940 350 0435	02.21095
HL7/...; HD 7/... (BM 740/746/748)	<ul style="list-style-type: none"> EN Repair kit, wheel hub planetary gear, ABS DE Reparatursatz, Radnabe Planetengetriebe, ABS FR Kit de réparation, moyeu de roue relais réducteur, ABS ES Juego reparación, buje de rueda engranaje planetario, ABS PT Kit reparo, cubo roda planetário, ABS RU Ремонтный комплект, Ступица колеса планетарного механизма, ABS 		659 350 0035	02.21093
H 740/741/746/748, 749	<ul style="list-style-type: none"> EN Seal ring kit DE Dichtringsatz FR Jeu de bagues d'étanchéité ES Juego de retenes PT Jogo anel vedação RU Комплект уплотнительных колец 			02.23377
H 740/741/746/748, 749	<ul style="list-style-type: none"> EN Seal ring kit DE Dichtringsatz FR Jeu de bagues d'étanchéité ES Juego de retenes PT Jogo anel vedação RU Комплект уплотнительных колец 			02.23378







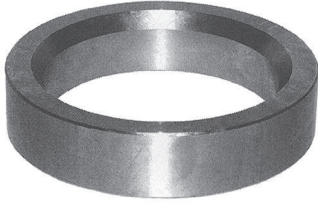

Sample

Application	Description	Details	Ref.	Erqo No.
H 740/748	<ul style="list-style-type: none"> EN O-ring DE O-Ring FR Joint torique ES Junta tórica PT Anel RU Уплотнительное кольцо 	255,0 x 5,0 mm	027 997 2248	02.22735 
H 740/746/748/749	<ul style="list-style-type: none"> EN Oil seal DE Wellendichtring FR Joint speed ES Anillo retén PT Retentor RU Сальник 	145 x 175 x 14 / 12	016 997 5647	02.22689 
H 740/748	<ul style="list-style-type: none"> EN Oil seal DE Wellendichtring FR Joint speed ES Anillo retén PT Retentor RU Сальник 	145 x 175 x 205 x 18 / 20	020 997 0547	02.22696 
H 740/741/746/748, 749	<ul style="list-style-type: none"> EN Oil seal DE Wellendichtring FR Joint speed ES Anillo retén PT Retentor RU Сальник 	145 x 175 x 13 / 12	013 997 9447	02.22677 

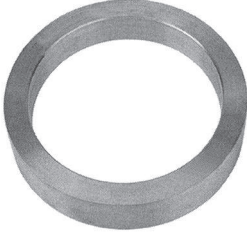







Sample

THE ORIGINAL NUMBERS OF THE VEHICLE MANUFACTURER MAY BE USED FOR COMPARISON PURPOSES ONLY AND MUST NOT BE MENTIONED ON INVOICES TO VEHICLE OWNERS.

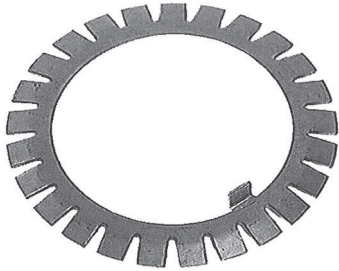

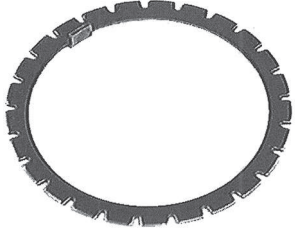





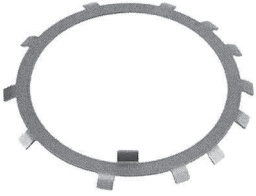

Application	Description	Details	Ref.	Erqo No.
H 740/748	<ul style="list-style-type: none"> EN Oil seal DE Wellendichtring FR Joint speed ES Anillo retén PT Retentor RU Сальник 	145 x 175 x 205 x 9/14	015 997 4947	02.22685 
H 740/746/748	<ul style="list-style-type: none"> EN Oil seal DE Wellendichtring FR Joint speed ES Anillo retén PT Retentor RU Сальник 	145 x 175 x 17/21	020 997 3947	02.22698 
H 746/748	<ul style="list-style-type: none"> EN Seal ring DE Dichtring FR Bague d'étanchéité ES Retén PT Anel vedação RU Уплотнительное кольцо 		013 997 8946	02.22648 
H 741/746/748	<ul style="list-style-type: none"> EN Oil seal DE Wellendichtring FR Joint speed ES Anillo retén PT Retentor RU Сальник 		013 997 3546	02.22644 
H 746/748	<ul style="list-style-type: none"> EN Oil seal DE Wellendichtring FR Joint speed ES Anillo retén PT Retentor RU Сальник 		014 997 0546	02.22649 

Application	Description	Details	Ref.	Erqo No.
HL 7/...; HD 7/ (B M 740/748)	<ul style="list-style-type: none"> EN Thrust ring DE Druckring FR Fret de joint speed ES Anillo de presión PT Anel pressão RU Упорное кольцо 	Ø 110 / 145 x 32 mm	355 356 1215	02.21128 
				
HL7/...; HD 7 /... (BM 740/748)	<ul style="list-style-type: none"> EN Thrust ring DE Druckring FR Fret de joint speed ES Anillo de presión PT Anel pressão RU Упорное кольцо 	Ø 115 / 145 x 32 mm	346 356 1415	02.21127 
				
740/746/748	<ul style="list-style-type: none"> EN Tapered roller bearing DE Kegelrollenlager FR Roulement à rouleaux coniques ES Rodamiento de rodillos cónicos PT Rolamento eixo RU Роликоподшипник 	repl. FAG 33022	004 981 0905	02.22336 
				
740/746/748	<ul style="list-style-type: none"> EN Tapered roller bearing DE Rollenlager FR Roulement à rouleaux coniques ES Rodamiento de rodillos cónicos PT Rolamento eixo RU Конический роликоподшипник 	repl. FAG: 567549	009 981 4305	02.22346 
				
740/748	<ul style="list-style-type: none"> EN Tapered roller bearing DE Kegelrollenlager FR Roulement à rouleaux coniques ES Rodamiento de rodillos cónicos PT Rolamento eixo RU Конический роликоподшипник 	repl. FAG: 33021	005 981 4905	02.22340 
				

THE ORIGINAL NUMBERS OF THE VEHICLE MANUFACTURER MAY BE USED FOR COMPARISON PURPOSES ONLY AND MUST NOT BE MENTIONED ON INVOICES TO VEHICLE OWNERS.

Application	Description	Details	Ref.	Erqo No.
HL 7/...; HD 7 /... (BM 740/748)	EN Cover plate DE Abdeckplatte FR Tôle Roulement ES Placa cobertera PT Cobertura RU Защитная пластина		946 356 0127	02.21135 
HL 7/...; HD 7/... (BM 740/748)	EN Lock sheet DE Sicherungsblech FR Arrêtoir ES Chapa de seguridad PT Anel trava RU Стопорная шайба		355 356 0173	02.21137 
HL7/...; HD 7/... (BM 740/748)	EN Lock sheet DE Sicherungsblech FR Toile d'arrêtoir ES Chapa de seguridad PT Anel trava RU Стопорная шайба		346 356 0073	02.21136 
V 730, 731, H 740, 744, 746, 748	EN Grooved nut DE Nutmutter FR Ecrou à gorge ES Tuercas ranurada PT Porca ranhurada RU Шлицевая гайка	M 88 x 1,5	942 356 0026	02.21132 
V 730, 731, 733, H 740, 746, 748	EN Grooved nut DE Nutmutter FR Ecrou à gorge ES Tuercas ranurada PT Porca ranhurada RU Шлицевая гайка	M 88 x 1,5	942 356 0126	02.21133 







THE ORIGINAL NUMBERS OF THE VEHICLE MANUFACTURER MAY BE USED FOR COMPARISON PURPOSES ONLY AND MUST NOT BE MENTIONED ON INVOICES TO VEHICLE OWNERS.

Application	Description	Details	Ref.	Erqo No.
HL 7/...; HD 7/... (BM 740/746/748)	<ul style="list-style-type: none"> EN Washer DE Scheibe FR Rondelle ES Arandela PT Arruela RU Шайба 		346 336 0062	02.21055 
HL 6 / ...; H 06 / ... HL 8/...; HO 8/... (BM 741/746/748)	<ul style="list-style-type: none"> EN Lock washer DE Sicherungsscheibe FR Disque de sécurité ES Arandela de seguridad PT Arruela trava RU Стопорная шайба 		946 356 0073	02.21138 
HL 7/...; HD 7 /... (BM 740/746/748)	<ul style="list-style-type: none"> EN Spacer washer, 0,10 mm DE Abstandscheibe, 0,10 mm FR Entretoise, 0,10 mm ES Arandela distanciadora, 0,10 mm PT Arruela espaçadora, 0,10 mm RU Дистанционная шайба, 0,10 мм 		355 354 0752	02.21124 
HL 7/...; HD 7/... (BM 740/746/748)	<ul style="list-style-type: none"> EN Spacer washer, 0,50 mm DE Abstandscheibe, 0,50 mm FR Entretoise, 0,50 mm ES Arandela distanciadora, 0,50 mm PT Arruela espaçadora, 0,50 mm RU Дистанционная шайба, 0,50 мм 		355 354 0552	02.21123 
				Sample
HL 7/...; HD 7/... (BM 740/746/748)	<ul style="list-style-type: none"> EN Spacer washer, 1,50 mm DE Abstandscheibe, 1,50 mm FR Entretoise, 1,50 mm ES Arandela distanciadora, 1,50 mm PT Arruela espaçadora, 1,50 mm RU Дистанционная шайба, 1,50 мм 		498 354 0152	02.21125 
				Sample

THE ORIGINAL NUMBERS OF THE VEHICLE MANUFACTURER MAY BE USED FOR COMPARISON PURPOSES ONLY AND MUST NOT BE MENTIONED ON INVOICES TO VEHICLE OWNERS.

Application	Description	Details	Ref.	Erqo No.
V 730, 731, H 740, 746, 748	<ul style="list-style-type: none"> EN Lock ring DE Sicherungsring FR Clip de verrouillage ES Anillo de seguridad PT Anel trava RU Стопорное кольцо 			02.22644 
HL7/...; HD 7/... (BM 740/746/748)	<ul style="list-style-type: none"> EN Gasket DE Dichtung FR Joint ES Junta PT Junta RU Уплотнение 		650 356 0180	02.21142 
HL7/...; HD 7/... (BM 740/746/748)	<ul style="list-style-type: none"> EN Gasket DE Dichtung FR Joint ES Junta PT Junta RU Уплотнение 		650 356 0080	02.21141 
H 748	<ul style="list-style-type: none"> EN Screw DE Schraube FR Vis ES Tornillo PT Parafuso RU Болт 		M 12 x 1,5 x 30	02.22458 
H 740, 748	<ul style="list-style-type: none"> EN Screw DE Schraube FR Vis ES Tornillo PT Parafuso RU Болт 		M 12 x 1,5 x 25	005 990 6104 02.22436 

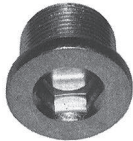
THE ORIGINAL NUMBERS OF THE VEHICLE MANUFACTURER MAY BE USED FOR COMPARISON PURPOSES ONLY AND MUST NOT BE MENTIONED ON INVOICES TO VEHICLE OWNERS.

Application	Description	Details	Ref.	Erqo No.
H 743, 744, 745	<ul style="list-style-type: none"> EN Stud DE Stiftschraube FR Goujon ES Prisionero PT Prisioneiro RU Шпилька 	M 12 x 1,5	312 990 2105	02.22458 
				
OM 401 LA Euro I, OM 402 LA Euro I, OM 441 + LA, OM 442 + LA (motor 789374--) V 730, 731, 733 H 740, 741, 742, 744, 745, 746, 748 GM 710/717	<ul style="list-style-type: none"> EN Drain plug DE Verschlusschraube FR Bouchon de vidange ES Tapón roscado PT Vujão RU Резьбовая пробка 	M 24 x 1,5	352 997 0032	02.22600 
				
V 730, 731, 733 H 740, 746, 748	<ul style="list-style-type: none"> EN Drain plug DE Verschlusschraube FR Bouchon de vidange ES Tapón roscado PT Vujão RU Резьбовая пробка 	M 24 x 1,5	624 997 0032	02.22605 
				
V 730, 731, 733 H 740, 746, 748	<ul style="list-style-type: none"> EN Drain plug DE Verschlusschraube FR Bouchon de vidange ES Tapón roscado PT Vujão RU Резьбовая пробка 	M 45 x 1,5	355 997 0232	02.22601 
				









THE ORIGINAL NUMBERS OF THE VEHICLE MANUFACTURER MAY BE USED FOR COMPARISON PURPOSES ONLY AND MUST NOT BE MENTIONED ON INVOICES TO VEHICLE OWNERS.

Application	Description	Details	Ref.	Erqo No.
BM 730, 731, 739 BM 742, 744, 749	<ul style="list-style-type: none"> EN Wheel bolt, complete with wheel bolt DE Radbolzen, komplett mit Radbolzen FR Goujon de roue, complet avec goujon de roue ES Perno de rueda, completo con perno de rueda PT Parafuso roda, completo com parafuso RU Колесные болты, в сборе с болтом крепления колеса 		000 401 2471 S1	02.23198 
BM 381/383/385/387, 393/395 616/617/619, 620/621/622/623/ 624/625, 645/646/647/648/649, 652/653/654/655/ 656/657/658/659	<ul style="list-style-type: none"> EN Wheel bolt, complete with wheel bolt DE Radbolzen, komplett mit Radbolzen FR Goujon de roue, complet avec goujon de roue ES Perno de rueda, completo con pivotes de rueda PT Parafuso roda, completo com parafuso RU Колесные болты, в сборе с болтом крепления колеса 		000 401 2471 S2	02.23199 
BM 730, 731, 739 B M 742, 744, 749	<ul style="list-style-type: none"> EN Wheel bolt, complete with wheel bolt DE Radbolzen, komplett mit Radbolzen FR Goujon de roue, complet avec goujon de roue ES Perno de rueda, completo con pivotes de rueda PT Parafuso roda, completo com parafuso RU Колесные болты, в сборе с болтом крепления колеса 		000 401 2471 S3	02.23200 
BM 381/383/385/387, 393/395 616/617/619, 620/621/622/623/ 624/625, 645/646/647/648/649, 652/653/654/655/ 656/657/658/659	<ul style="list-style-type: none"> EN Wheel bolt, complete with wheel bolt DE Radbolzen, komplett mit Radbolzen FR Goujon de roue, complet avec goujon de roue ES Perno de rueda, completo con perno de rueda PT Parafuso roda, completo com parafuso RU Колесные болты, в сборе с болтом крепления колеса 		000 401 2471 S4	02.23201 









THE ORIGINAL NUMBERS OF THE VEHICLE MANUFACTURER MAY BE USED FOR COMPARISON PURPOSES ONLY AND MUST NOT BE MENTIONED ON INVOICES TO VEHICLE OWNERS.

Wheel Bolts

Radbolzen • Goujons de roue • Pernos de rueda
Parafusos de roda • Болты крепления колеса

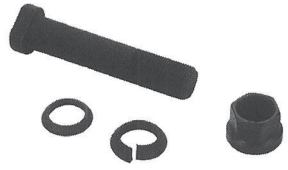
Application	Description	Details	Ref.	Erqo No.
732, 797, 739 391/399 744 400/401/402, 405/407/412/413/414, 430/431/434/435/438, 442/443/445/508/532, 745 100/101/113/131/142	<p>EN Wheel bolt, complete with wheel bolt</p> <p>DE Radbolzen, komplett mit Radbolzen</p> <p>FR Goujon de roue, complet avec goujon de roue</p> <p>ES Perno de rueda, completo con perno de rueda</p> <p>PT Parafuso roda, completo com parafuso</p> <p>RU Колесные болты, в сборе с болтом крепления колеса</p>		381 401 0571 S1	02.23202 
732, 797, 739 391/399 744 400/401/402, 405/407/412/413/414, 430/431/434/435/438, 442/443/445/508/532, 745 100/101/113/131/142	<p>EN Wheel bolt, complete with wheel bolt</p> <p>DE Radbolzen, komplett mit Radbolzen</p> <p>FR Goujon de roue, complet avec goujon de roue</p> <p>ES Perno de rueda, completo con perno de rueda</p> <p>PT Parafuso roda, completo com parafuso</p> <p>RU Колесные болты, в сборе с болтом крепления колеса</p>		381 401 0571 S2	02.23203 
BM 740, 748, 749 BM 381/385/387/393, 616/617/619, 620/622/623, 645/647/655	<p>EN Wheel bolt, complete with wheel bolt</p> <p>DE Radbolzen, komplett mit Radbolzen</p> <p>FR Goujon de roue, complet avec goujon de roue</p> <p>ES Perno de rueda, completo con perno de rueda</p> <p>PT Parafuso roda, completo com parafuso</p> <p>RU Колесные болты, в сборе с болтом крепления колеса</p>		381 401 0571 S3	02.23204 
BM 740, 748, 749 BM 381/385/387/393, 616/617/619, 620/622/623, 645/647/655	<p>EN Wheel bolt, complete with wheel bolt</p> <p>DE Radbolzen, komplett mit Radbolzen</p> <p>FR Goujon de roue, complet avec goujon de roue</p> <p>ES Perno de rueda, completo con perno de rueda</p> <p>PT Parafuso roda, completo com parafuso</p> <p>RU Колесные болты, в сборе с болтом крепления колеса</p>		381 401 0671 S1	02.23205 

THE ORIGINAL NUMBERS OF THE VEHICLE MANUFACTURER MAY BE USED FOR COMPARISON PURPOSES ONLY AND MUST NOT BE MENTIONED ON INVOICES TO VEHICLE OWNERS.

Application	Description	Details	Ref.	Erqo No.
BM 740	<ul style="list-style-type: none"> EN Wheel bolt, complete with wheel bolt DE Radbolzen, komplett mit Radbolzen FR Goujon de roue, complet avec goujon de roue ES Perno de rueda, completo con perno de rueda PT Parafuso roda, completo com parafuso RU Колесные болты, в сборе с болтом крепления колеса 		381 401 0671 S2	02.23206 
BM 381/383/385 616/617/619				
BM 740	<ul style="list-style-type: none"> EN Wheel bolt, complete with wheel bolt DE Radbolzen, komplett mit Radbolzen FR Goujon de roue avec goujon de roue ES Perno de rueda, completo con perno de rueda PT Parafuso roda, completo com parafuso RU Колесные болты, в сборе с болтом крепления колеса 		381 401 0671 S3	02.23207 
BM 381/383/385 616/617/619				
BM 740,748	<ul style="list-style-type: none"> EN Wheel bolt, complete with wheel bolt DE Radbolzen, komplett mit Radbolzen FR Goujon de roue, complet avec goujon de roue ES Perno de rueda, completo con pivotes de rueda PT Parafuso roda, completo com parafuso RU Колесные болты, в сборе с болтом крепления колеса 		000 401 3771 S1	02.23208 
BM 385/387/389/393/395 617/619, 620/621/624/625, 645/646/649, 655/656/659				
BM 740,748	<ul style="list-style-type: none"> EN Wheel bolt, complete with wheel bolt DE Radbolzen, komplett mit Radbolzen FR Goujon de roue, complet avec goujon de roue ES Perno de rueda, completo con pivotes de rueda PT Parafuso roda, completo com parafuso RU Колесные болты, в сборе с болтом крепления колеса 		000 401 3771 S2	02.23209 
BM 385/387/389/393/395 617/619, 620/621/624/625, 645/646/649, 655/656/659				

THE ORIGINAL NUMBERS OF THE VEHICLE MANUFACTURER MAY BE USED FOR COMPARISON PURPOSES ONLY AND MUST NOT BE MENTIONED ON INVOICES TO VEHICLE OWNERS.

Wheel Bolts

Radbolzen • Goujons de roue • Pernos de rueda
Parafusos de roda • Болты крепления колеса

Application	Description	Details	Ref.	Erqo No.
BM 740,748 BM 385/387/389/393/395 617/619, 620/621/624/625, 645/646/649, 655/656/659	<ul style="list-style-type: none"> EN Wheel bolt, complete with wheel bolt DE Radbolzen, komplett mit Radbolzen FR Goujon de roue, complet avec goujon de roue ES Perno de rueda, completo con pivotes de rueda PT Parafuso roda, completo com parafuso RU Колесные болты, в сборе с болтом крепления колеса 		000 401 3771 S3	02.23210 
BM 740,748 BM 385/387/389/393/395 617/619, 620/621/624/625, 645/646/649, 655/656/659	<ul style="list-style-type: none"> EN Wheel bolt, complete with wheel bolt DE Radbolzen, komplett mit Radbolzen FR Goujon de roue, complet avec goujon de roue ES Perno de rueda, completo con pivotes de rueda PT Parafuso roda, completo com parafuso RU Колесные болты, в сборе с болтом крепления колеса 		000 401 3771 S4	02.23211 
BM 730, 731, 739 BM 742, 744, 749 BM 381/383/385/387, 393/395 616/617/619, 620/621/622/623/ 624/625, 645/646/647/648/649, 652/653/654/655/ 656/657/658/659	<ul style="list-style-type: none"> EN Wheel bolt DE Radbolzen FR Goujon de roue ES Perno de rueda PT Parafuso roda RU Колесный болт 	M 22 x 1,5 x 90,5 / 80 mm	389 401 0071	02.21158 
732, 797, 739 391/399 744 400/401/402, 405/407/412/413/414, 430/431/434/435/438, 442/443/445/508/532, 745 100/101/113/131/142	<ul style="list-style-type: none"> EN Wheel bolt DE Radbolzen FR Goujon de roue ES Perno de rueda PT Parafuso roda RU Колесный болт 	M 22 x 1,5 x 99 / 88,5 mm	389 401 0171	02.21159 
BM 739, BM 741, 746, 748	<ul style="list-style-type: none"> EN Wheel bolt DE Radbolzen FR Goujon de roue ES Perno de rueda PT Parafuso roda RU Колесный болт 	M 22 x 1,5 x 96,5 / 86 mm	948 401 0271	02.21160 

THE ORIGINAL NUMBERS OF THE VEHICLE MANUFACTURER MAY BE USED FOR COMPARISON PURPOSES ONLY AND MUST NOT BE MENTIONED ON INVOICES TO VEHICLE OWNERS.





Application	Description	Details	Ref.	Erqo No.
BM 730/731, BM 742, 744, 749 BM 381/383/385/387/389, 395 616/617/619, 620/621, 623/624/625, 646, 648/649, 652, 655/656, 658/659	(EN) Wheel bolt (DE) Radbolzen (FR) Goujon de roue (ES) Perno de rueda (PT) Parafuso roda (RU) Колесный болт	22 x 1,5 x 108,5 / 98 mm	381 401 0571	02.21151 
B M 740, 748, 749 BM 381/385/387/393, 616/617/619, 620/622/623, 645/647/655	(EN) Wheel bolt (DE) Radbolzen (FR) Goujon de roue (ES) Perno de rueda (PT) Parafuso roda (RU) Колесный болт	M 22 x 1,5 x 115,5 / 105 mm	381 401 0671	02.21152 
BM 740 BM 381/383/385 616/617/619	(EN) Wheel bolt (DE) Radbolzen (FR) Goujon de roue (ES) Perno de rueda (PT) Parafuso roda (RU) Колесный болт	M 22 x 1,5 x 125,5 / 115 mm	381 401 0871	02.21155 
BM 740,748 BM 385/387/389/393/395 617/619, 620/621/624/625, 645/646/649, 655/656/659	(EN) Wheel bolt, surface: geomet (DE) Radbolzen, Oberfläche: geometisiert (FR) Goujon de roue, surface: geomet (ES) Perno de rueda, revestimiento: geomet (PT) Parafuso roda, superfície: geomat (RU) Колесный болт, поверхность: геомет	M 22 x 1,5 x 121 / 110,5 mm	381 401 0771	02.21153 
BM 740,748 BM 385/387/389/393/395 617/619, 620/621/624/625, 645/646/649, 655/656/659	(EN) Wheel bolt, surface: phosphated (DE) Radbolzen, Oberfläche: phosphatiert (FR) Goujon de roue, surface: phosphate (ES) Perno de rueda, revestimiento: galvanizado (PT) Parafuso roda, superfície: fosfatizada (RU) Колесный болт, поверхность: фосфатизирована	M 22 x 1,5 x 121 / 110,5 mm	381 401 0771	02.21154 

THE ORIGINAL NUMBERS OF THE VEHICLE MANUFACTURER MAY BE USED FOR COMPARISON PURPOSES ONLY AND MUST NOT BE MENTIONED ON INVOICES TO VEHICLE OWNERS.

Wheel Bolts

Radbolzen • Goujons de roue • Pernos de rueda
Parafusos de roda • Болты крепления колеса







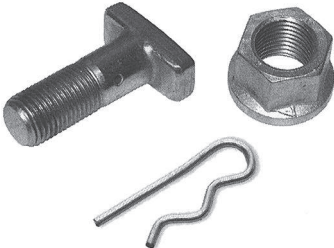

Application	Description	Details	Ref.	Erqo No.
NG/MK/SK	<ul style="list-style-type: none"> EN Wheel nut DE Radmutter FR Ecrou de roue ES Tuerca de la rueda PT Porca roda RU Гайка крепления колеса 	M 22 x 1,5	385 400 0124	02.21143 
				
NG/MK/SK	<ul style="list-style-type: none"> EN Wheel nut DE Radmutter FR Ecrou de roue ES Tuerca de la rueda PT Porca roda disco RU Гайка крепления колеса 	M 22 x 1,5	000 401 0672	02.21161 
				
NG/MK/SK	<ul style="list-style-type: none"> EN Wheel nut DE Radmutter FR Ecrou de roue ES Tuerca de la rueda PT Porca roda RU Гайка крепления колеса 	M 22 x 1,5	000 401 1072	02.21162 
				
NG/MK/SK	<ul style="list-style-type: none"> EN Wheel nut DE Radmutter FR Ecrou de roue ES Tuerca de la rueda PT Porca roda RU Гайка крепления колеса 	M 18 x 1,5	074361 018205	02.22928 
				
NG/MK/SK	<ul style="list-style-type: none"> EN Wheel nut DE Radmutter FR Ecrou de roue ES Tuerca de perno de rueda PT Porca roda RU Гайка крепления колеса 	M 22 x 1,5	074361 022204	02.22934 
				
NG/MK/SK	<ul style="list-style-type: none"> EN Wheel nut DE Radmutter FR Ecrou de roue ES Tuerca de perno de rueda PT Porca roda RU Гайка крепления колеса 	M 22 x 1,5	074361 022205	02.22935 
				

Application	Description	Details	Ref.	Erqo No.
NG/MK/SK	EN Washer DE Scheibe FR Rondelle ES Arandela PT Arruela RU Шайба		324 997 0026	02.22586 
NG/MK/SK	EN Coil washer DE Federring FR Rondelle ressort ES Arandela elástica PT Arruela elástica RU Пружинное кольцо		074361 018352	02.22929 
NG/MK/SK	EN Coil washer DE Federring FR Rondelle ressort ES Anillo PT Arruela elástica RU Пружинное кольцо		074361 020352	02.22932 
NG/MK/SK	EN Coil washer DE Federring FR Rondelle ressort ES Anillo PT Arruela elástica RU Пружинное кольцо		074361 022351	02.22936 
NG/MK/SK	EN Spherical ring DE Zentrierring FR Bague de centrage ES Anillo esférico PT Anel esférico RU Центрирующее кольцо		066 402 0075	02.21169 
NG/MK/SK	EN Spherical ring DE Zentrierring FR Bague de centrage ES Anillo esférico PT Anel esférico RU Центрирующее кольцо		317 402 0175	02.21170 

THE ORIGINAL NUMBERS OF THE VEHICLE MANUFACTURER MAY BE USED FOR COMPARISON PURPOSES ONLY AND MUST NOT BE MENTIONED ON INVOICES TO VEHICLE OWNERS.

Wheel Bolts

Radbolzen • Goujons de roue • Pernos de rueda
Parafusos de roda • Болты крепления колеса

Application	Description	Details	Ref.	Erqo No.
NG/MK/SK	<ul style="list-style-type: none"> EN Wheel bolt, complete with wheel bolt DE Radbolzen, komplett mit Radbolzen FR Goujon de roue, complet avec goujon de roue ES Perno de rueda, completo con perno de rueda PT Parafuso roda, completo com parafuso RU Колесные болты, в сборе с болтом крепления колеса 		395 401 0070 S	02.23212 
NG/MK/SK	<ul style="list-style-type: none"> EN Wheel bolt, complete with wheel bolt DE Radbolzen, komplett mit Radbolzen FR Goujon de roue avec goujon de roue ES Perno de rueda, completo con perno de rueda PT Parafuso roda, completo com parafuso RU Колесные болты, в сборе с болтом крепления колеса 		315 402 0070 S	02.23213 
NG/MK/SK	<ul style="list-style-type: none"> EN Wheel bolt, complete with wheel bolt DE Radbolzen, komplett mit Radbolzen FR Goujon de roue avec goujon de roue ES Perno de rueda, completo con perno de rueda PT Parafuso roda, completo com parafuso RU Колесные болты, в сборе с болтом крепления колеса 		315 402 0170 S	02.23214 
NG/MK/SK	<ul style="list-style-type: none"> EN Wheel bolt, complete with wheel bolt DE Radbolzen, komplett mit Radbolzen FR Goujon de roue avec goujon de roue ES Perno de rueda, completo con perno de rueda PT Parafuso roda, completo com parafuso RU Колесные болты, в сборе с болтом крепления колеса 		387 402 0470 S	02.23215 

THE ORIGINAL NUMBERS OF THE VEHICLE MANUFACTURER MAY BE USED FOR COMPARISON PURPOSES ONLY AND MUST NOT BE MENTIONED ON INVOICES TO VEHICLE OWNERS.











Application	Description	Details	Ref.	Erqo No.
NG/MK/SK	<ul style="list-style-type: none"> EN Wheel bolt, complete with wheel bolt DE Radbolzen, komplett mit Radbolzen FR Goujon de roue avec goujon de roue ES Perno de rueda, completo con perno de rueda PT Parafuso roda, completo com parafuso RU Колесные болты, в сборе с болтом крепления колеса 		395 401 0070 S	02.23212 
SK/MK/NG	<ul style="list-style-type: none"> EN Wheel bolt, complete with wheel bolt DE Radbolzen, komplett mit Radbolzen FR Goujon de roue, complet avec goujon de roue ES Perno de rueda, completo con perno de rueda PT Parafuso roda, completo com parafuso RU Колесные болты, в сборе с болтом крепления колеса 		315 402 0070 S	02.23213 
NG/MK/SK	<ul style="list-style-type: none"> EN Wheel bolt, trilex-system DE Radbolzen, Trilex-System FR Goujon de roue, trilex-system ES Perno de rueda, trilex-system PT Parafuso roda, sistema trilex RU Колесный болт, Система Trilex 	M 20 x 2 x 57 mm 	620 401 0070	02.21148 
NG/MK/SK	<ul style="list-style-type: none"> EN Wheel bolt, trilex-system DE Radbolzen, Trilex-System FR Goujon de roue, trilex-system ES Perno de rueda, Sistema-trilex PT Parafuso roda, sistema trilex RU Колесный болт, Система Trilex 	M 20 x 2 x 115 mm 	620 401 0170	02.21149 
NG/MK/SK	<ul style="list-style-type: none"> EN Wheel bolt, Trilex-system DE Radbolzen, Trilex-System FR Goujon de roue, système Trilex ES Perno de llanta, sistema Trilex PT Parafuso, sistema Trilex RU Болт крепления обода, Система Trilex 	M 18 x 2 x 80 mm 	387 402 0470	02.21168 

THE ORIGINAL NUMBERS OF THE VEHICLE MANUFACTURER MAY BE USED FOR COMPARISON PURPOSES ONLY AND MUST NOT BE MENTIONED ON INVOICES TO VEHICLE OWNERS.

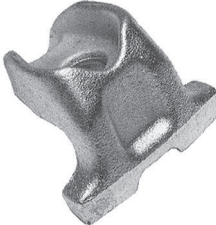
Wheel Bolts

Radbolzen • Goujons de roue • Pernos de rueda
Parafusos de roda • Болты крепления колеса









Application	Description	Details	Ref.	Erqo No.
NG/MK/SK	<ul style="list-style-type: none"> EN Wheel bolt, Trilex-system DE Radbolzen, Trilex-System FR Goujon de roue, système Trilex ES Perno de llanta, sistema Trilex PT Parafuso, sistema Trilex RU Болт крепления обода, Система Trilex 	M 18 x 2 x 110 mm	315 402 0070	02.21166 
				
NG/MK/SK	<ul style="list-style-type: none"> EN Wheel bolt, Trilex-system DE Radbolzen, Trilex-System FR Goujon de roue, système Trilex ES Perno de llanta, sistema Trilex PT Parafuso, sistema Trilex RU Болт крепления обода, Система Trilex 	M 18 x 2 x 125 mm	315 402 0170	02.21167 
				
NG/MK/SK	<ul style="list-style-type: none"> EN Wheel bolt, Trilex-system DE Radbolzen, Trilex-System FR Goujon de roue, système Trilex ES Perno de llanta, sistema Trilex PT Parafuso, sistema Trilex RU Болт крепления обода, Система Trilex 	M 20 x 2 x 75 mm	395 401 0070	02.21147 
				
NG/MK/SK	<ul style="list-style-type: none"> EN Wheel nut DE Radmutter FR Ecrou de roue ES Tuerca de perno de rueda PT Porca roda RU Гайка крепления колеса 	M 20 x 1,5	074361 020205	02.23216 
				
NG/MK/SK	<ul style="list-style-type: none"> EN Wheel nut, trilex-system DE Radmutter, Trilex-System FR Ecrou, trilex-system ES Tuerca de la rueda, Sistema Trilex PT Porca roda, sistema trilex RU Гайка, Система Trilex 	M 20 x 2	346 401 5072	02.21163 
				
NG/MK/SK	<ul style="list-style-type: none"> EN Wheel nut, trilex-system DE Radmutter, Trilex-System FR Ecrou, trilex-system ES Tuerca de la rueda, Sistema Trilex PT Porca roda, sistema trilex RU Гайка, Система Trilex 	M 20 x 2	346 401 5072	02.21164 
				







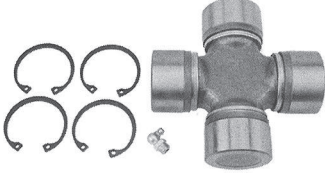

Application	Description	Details	Ref.	Erqo No.
NG/MK/SK	<ul style="list-style-type: none"> EN Washer DE Scheibe FR Rondelle ES Arandela PT Arruela RU Шайба 		620 990 0240	02.22469 
NG/MK/SK	<ul style="list-style-type: none"> EN Lock spring DE Sicherungsfeder FR Ressort de sécurité ES Resorte de seguridad PT Mola RU Стопорная пружина 		000 994 2260	02.22564 
NG/MK/SK	<ul style="list-style-type: none"> EN Clamping piece, trilex-system DE Klemmstück, Trilex-System FR Agrafe, trilex-system ES Pieza de apriete, Sistema-trilex PT Abraçadeira roda, sistema trilex RU Зажимный элемент, Система Trilex 		620 401 0169	02.21146 
NG/MK/SK	<ul style="list-style-type: none"> EN Clamping piece, trilex-system DE Klemmstück, Trilex-System FR Agrafe, trilex-system ES Pieza de apriete, Sistema-trilex PT Abraçadeira cubo, sistema trilex RU Зажимный элемент, Система Trilex 		620 402 0068	02.21165 
BPW	<ul style="list-style-type: none"> EN Wheel bolt DE Radbolzen FR Boulon de roue ES Pivote de rueda PT Parafuso roda RU Колесный болт 	M 22 x 2 x 87 mm	381 401 0671	02.21152 
				

THE ORIGINAL NUMBERS OF THE VEHICLE MANUFACTURER MAY BE USED FOR COMPARISON PURPOSES ONLY AND MUST NOT BE MENTIONED ON INVOICES TO VEHICLE OWNERS.

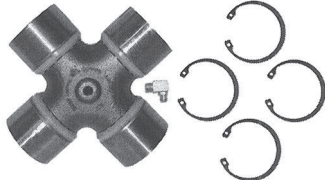
Wheel Bolts

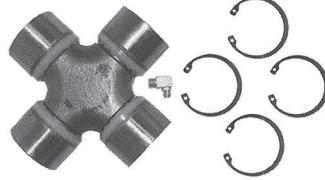
Radbolzen • Goujons de roue • Pernos de rueda
Parafusos de roda • Болты крепления колеса

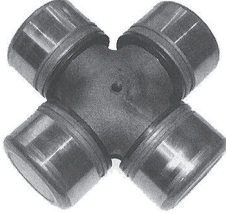
Application	Description	Details	Ref.	Erqo No.
BPW	<ul style="list-style-type: none"> EN Wheel bolt DE Radbolzen FR Goujon de roue ES Perno de rueda PT Parafuso roda RU Колесный болт 		03.296.23.17.0	02.23379 
BPW	<ul style="list-style-type: none"> EN Wheel bolt DE Radbolzen FR Goujon de roue ES Perno de rueda PT Parafuso roda RU Колесный болт 		03.296.13.09.0	02.23380 
BPW	<ul style="list-style-type: none"> EN Nut DE Radmutter FR Ecrou ES Tuerca de la rueda PT Porca RU Гайка 		03.260.04.06.0	02.23381 
BPW	<ul style="list-style-type: none"> EN Wheel nut DE Radmutter FR Ecrou ES Tuerca de la rueda PT Porca RU Гайка 		03.260.04.01.0	02.23382 

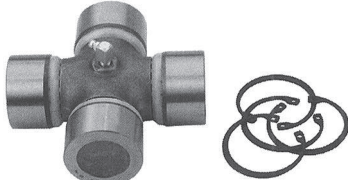
Application	Description	Details	Ref.	Erqo No.
NG/MK/SK	<ul style="list-style-type: none"> EN Joint cross DE Zapfenkreuz FR Croisillon ES Cruceta PT Cruzeta RU Крестовина карданного шарнира 	53 x 135 mm	000 410 1628	02.21180 
				
BM 387/389, 393/395, 620/621/622/623, 624	<ul style="list-style-type: none"> EN Joint cross DE Zapfenkreuz FR Croisillon ES Cruceta PT Cruzeta RU Крестовина карданного шарнира 	57 x 152,5 mm	387 410 0031	02.21184 
				
NG/MK/SK	<ul style="list-style-type: none"> EN Joint cross DE Zapfenkreuz FR Croisillon ES Cruceta PT Cruzeta RU Крестовина карданного шарнира 	48 x 126 mm	973 410 0031	02.21190 
				
3535, 3538, 3548, 1824,1827,1838, 1844,1850, 2538, 2544,1748,1850, 1935, 2435, 2550, 1929,1945,1948, 2538, 2544, 2550, 2448, 2550, 2553, 3248, 3255	<ul style="list-style-type: none"> EN Joint cross DE Zapfenkreuz FR Croisillon ES Cruceta PT Cruzeta RU Крестовина карданного шарнира 	68 x 166 mm	656 410 0131	02.21187 
				
NG/MK/SK	<ul style="list-style-type: none"> EN Joint cross DE Zapfenkreuz FR Croisillon ES Cruceta PT Cruzeta RU Крестовина карданного шарнира 	68 x 166 mm	942 410 0131	02.21189 
				

THE ORIGINAL NUMBERS OF THE VEHICLE MANUFACTURER MAY BE USED FOR COMPARISON PURPOSES ONLY AND MUST NOT BE MENTIONED ON INVOICES TO VEHICLE OWNERS.

Application	Description	Details	Ref.	Erqo No.
BM 625.374, 649.196, 655.327, 656.322/327, 659.196	<ul style="list-style-type: none"> EN Joint cross DE Zapfenkreuz FR Croisillon ES Cruceta PT Cruzeta RU Крестовина карданного шарнира 	65 x 172 mm 	645 410 0131	02.21186 
NG/MK/SK	<ul style="list-style-type: none"> EN Joint cross DE Zapfenkreuz FR Croisillon ES Cruceta PT Cruzeta RU Крестовина карданного шарнира 	57 x 152 mm 	940 410 0031	02.21188 
BM 383/385/387/389, 393/395, 620/621/623 --Id-No. 5092170	<ul style="list-style-type: none"> EN Housing, complete DE Gehäuse, komplett FR Carter, complet ES Caja, completo PT Carcaça, completa RU Корпус, в сборе 	Ø 60 mm 	387 410 0010	02.21171 
BM 383/385/387/389, 393/395, 620/621/623	<ul style="list-style-type: none"> EN Housing DE Gehäuse FR Carter ES Caja PT Carcaça RU Корпус 	Ø 128 mm 	363 413 0001	02.21192 
BM 383/385/387/389, 393/395, 620/621/623	<ul style="list-style-type: none"> EN Rubber mounting DE Gummilager FR Silentbloc ES Cojinete de goma PT Coxim cardan RU Саленблок 	102 x 128 x 40 mm 	363 413 0012	02.21193 

THE ORIGINAL NUMBERS OF THE VEHICLE MANUFACTURER MAY BE USED FOR COMPARISON PURPOSES ONLY AND MUST NOT BE MENTIONED ON INVOICES TO VEHICLE OWNERS.

Application	Description	Details	Ref.	Erqo No.
BM 383/385/387/389, 393/395, 620/621/623	<ul style="list-style-type: none"> EN Ball bearing, center bearing DE Kugellager, Mittellager FR Roulement à billes, palier de transmission ES Rodamiento de bolas, Rodamiento central PT Rolamento cardan, Rolamento intermedio RU Шариковый, подшипник 	Ø 60 mm	363 410 0151	02.21191 
BM 387/389, 391/393, 617/619, 620/621/623/625, 651/652/653, 656	<ul style="list-style-type: none"> EN Center bearing DE Mittellager FR Palier relais de transmission ES Cojinete intermedio PT Rolamento central RU Промежуточный подшипник 	Ø 60 mm	654 410 0022	02.21177 
Id-No. 5092171--				
BM 620/621/624/625, 645/646/648/649, 652/653/654/655/ 656/658/659	<ul style="list-style-type: none"> EN Center bearing DE Mittellager FR Palier de transmisson ES Cojinete intermedio PT Rolamento central RU Промежуточный подшипник 	Ø 70 mm	655 410 0022	02.21178 
BM 385/387, 615/616/617/619, 621, 650/651/652/653, 654/656	<ul style="list-style-type: none"> EN Rubber bearing DE Gummilager FR Silentbloc ES Cojinete de goma PT Coxim RU Сайлентблок 	Ø 55 mm	385 410 0922	02.21173 
-- Id-No. 5722264				
BM 381/383/385, 616/617/619, 621, 651/652/653/654, 656	<ul style="list-style-type: none"> EN Center bearing DE Mittellager FR Palier relais de transmission ES Cojinete intermedio PT Rolamento central RU Промежуточный подшипник 	Ø 55 mm	973 410 0022	02.21179 
Id-No. 5722265--				

THE ORIGINAL NUMBERS OF THE VEHICLE MANUFACTURER MAY BE USED FOR COMPARISON PURPOSES ONLY AND MUST NOT BE MENTIONED ON INVOICES TO VEHICLE OWNERS.

Application	Description	Details	Ref.	Erqo No.
BM 620/621/624/625, 645/646/648/649, 652/653/654/655/ 656/658/659	<p>EN Center bearing without bearing old version</p> <p>DE Mittellager ohne Kugellager alte Ausführung</p> <p>FR Palier relais de transmission, sans roulement ancienne version</p> <p>ES Cojinete intermedio, sin rodamiento versión antigua</p> <p>PT Borracha cardã, sem rolamento versão antiga</p> <p>RU Корпус подшипника, без Конический роликоподшипник старая версия</p>		395 410 0022	02.21175 
BM 383/385/387/389, BM 616/617/619, BM 621/624/625, B M 646/649	<p>EN Bolt with safety nut</p> <p>DE Bolzen mit Mutter</p> <p>FR Jeu d'axes</p> <p>ES Perno con tuerca</p> <p>PT Parafuso com porca segurança</p> <p>RU Болт с гайкой</p>	M 12 x 1,25	360 990 3001	02.22418 
BM 395	<p>EN Bolt with safety nut</p> <p>DE Bolzen mit Mutter</p> <p>FR Jeu d'axes</p> <p>ES Perno con tuerca</p> <p>PT Parafuso com porca segurança</p> <p>RU Болт с гайкой</p>	M 16 x 1,5	395 990 0001	02.22419 
NG/MK/SK	<p>EN Bolt with safety nut</p> <p>DE Bolzen mit Mutter</p> <p>FR Jeu d'axes</p> <p>ES Perno con tuerca</p> <p>PT Parafuso com porca segurança</p> <p>RU Болт с гайкой</p>	M 16 x 1,5	395 990 0501	02.22422 
BM 383/385, 616/619, 652/653	<p>EN Bolt with safety nut</p> <p>DE Bolzen mit Mutter</p> <p>FR Jeu d'axes</p> <p>ES Perno con tuerca</p> <p>PT Parafuso com porca segurança</p> <p>RU Болт с гайкой</p>	M 10 x 1	007 990 1001	02.22416 

Application	Description	Details	Ref.	Erqo No.
731/733	<ul style="list-style-type: none"> EN Brake drum DE Bremstrommel FR Tambour de frein ES Tambor de freno PT Tambor freio RU Тормозной барабан 	410 x 160 x 250 mm	387 421 0001	02.21242 
Sample				
730/739	<ul style="list-style-type: none"> EN Brake drum old version DE Bremstrommel alte Ausführung FR Tambour de frein ancienne version ES Tambor de freno version antigua PT Tambor freio version antiga RU Тормозной барабан старое исполнение 	410 x 180 x 237 mm	624 421 0201	02.21244 
Sample				
730/739	<ul style="list-style-type: none"> EN Brake drum new version DE Bremstrommel neue Ausführung FR Tambour de frein nouvelle version ES Tambor de freno nueva versión PT Tambor freio versão nova RU Тормозной барабан новая версия 	410 x 180 x 237 mm	658 421 0001	02.21245 



Brake Drum

Bremstrommel • Tambour de frein • Tambor de freno
Tambor freio • Тормозной барабан

Application	Description	Details	Ref.	Erqo No.
731/733/739, 749	EN Brake drum DE Bremstrommel FR Tambour de frein ES Tambor de freno PT Tambor freio RU Тормозной барабан	410 x 160 x 213 mm	305 421 0401	02.21241 
				
				Sample
730/731	EN Brake drum DE Bremstrommel FR Tambour de frein ES Tambor de freno PT Tambor freio RU Тормозной барабан	410 x 180 x 260 mm	387 421 0201	02.21243 
				
				Sample
740/746/748	EN Brake drum DE Bremstrommel FR Tambour de frein ES Tambor de freno PT Tambor freio RU Тормозной барабан	410 x 180 x 280 mm	346 423 0501	02.21262 
				

Brake Drum

Bremstrommel • Tambour de frein • Tambor de freno
 Tambor freio • Тормозной барабан

Application	Description	Details	Ref.	Erqo No.
740/748	<ul style="list-style-type: none"> EN Brake drum DE Bremstrommel FR Tambour de frein ES Tambor de freno PT Tambor freio RU Тормозной барабан 	410 x 220 x 306 mm	305 423 0401	02.21261 
				
740/746/748	<ul style="list-style-type: none"> EN Brake drum DE Bremstrommel FR Tambour de frein ES Tambor de freno PT Tambor freio RU Тормозной барабан 	410 x 160 x 270 mm	346 423 0601	02.21263 
				
		Sample		
730/731/739, 740/748/749	<ul style="list-style-type: none"> EN Brake shoe welded version DE Bremsbacke geschweißte Ausführung FR Mâchoire de frein version moulée ES Zapata de freno version fundida PT Sapata freio versão aço RU Тормозная колодка сварное исполнение 	160 mm	659 420 0019	02.21198 
				

Brake Drum

Bremstrommel • Tambour de frein • Tambor de freno
Tambor freio • Тормозной барабан

Application	Description	Details	Ref.	Erqo No.
730/731/739, 740/748	(EN) Brake shoe casting version (DE) Bremsbacke Guss-Ausführung (FR) Mâchoire de frein version acier (ES) Zapata de freno version fundida (PT) Sapata freio versão ferro fundido (RU) Тормозная колодка литое исполнение	180 mm	659 420 0619	02.21200 

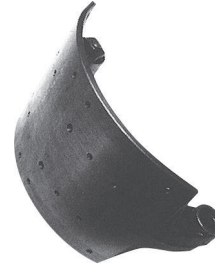

Sample

740/748	(EN) Brake shoe casting version (DE) Bremsbacke Guss-Ausführung (FR) Mâchoire de frein version acier (ES) Zapata de freno version fundida (PT) Sapata freio versão ferro fundido (RU) Тормозная колодка литое исполнение	220 mm	659 420 0519	02.21199 
---------	---	--------	--------------	--





7

730/731/739, 740/748/749	(EN) Drum brake lining kit, axle kit (DE) Trommelbremsbelagsatz, Achssatz (FR) Jeu de garnitures de frein à tambour, Jeu d'essieu (ES) Juego de forros de freno de tambor (PT) Jogo tambor freio , Jogo de eixos (RU) Комплект тормозных накладок	WVA 19494- 18,0 mm / 160 mm	617 423 1830	02.21275 
-----------------------------	---	-----------------------------	--------------	---



Sample

THE ORIGINAL NUMBERS OF THE VEHICLE MANUFACTURER MAY BE USED FOR COMPARISON PURPOSES ONLY AND MUST NOT BE MENTIONED ON INVOICES TO VEHICLE OWNERS.

Application	Description	Details	Ref.	Erqo No.
730/731/739, 740/746/748	<ul style="list-style-type: none"> EN Drum brake lining kit, axle kit DE Trommelbremsbelagsatz, Achssatz FR Jeu de garnitures de frein à tambour, Jeu d'essieu ES Juego de forros de freno de tambor PT Jogo tambor freio, Jogo de eixos RU Комплект тормозных накладок 	WVA 19495 - 18,0 mm / 180 mm	617 423 1430	02.21273 
730/731/739, 740/746/748	<ul style="list-style-type: none"> EN Drum brake lining kit, axle kit - oversize DE Trommelbremsbelagsatz, Achssatz - ÜbergroÙe FR Jeu de garnitures de frein à tambour, Jeu d'essieu - surdimensionné ES Juego de forros de freno de tambor, extragrandes PT Jogo tambor freio, Jogo de eixos - extra grande RU Комплект тормозных накладок - негабарит 	WVA 19495 - 16,7 mm / 180 mm	617 423 1330	02.21272 
730/731/739, 740/746/748	<ul style="list-style-type: none"> EN Drum brake lining kit, axle kit - oversize DE Trommelbremsbelagsatz, Achssatz - ÜbergroÙe FR Jeu de garnitures de frein à tambour, Jeu d'essieu - surdimensionné ES Juego de forros de freno de tambor, extra grandes PT Jogo tambor freio, Jogo de eixos - extra grande RU Комплект тормозных накладок - негабарит 	WVA 19495- 18,8 mm / 180 mm	617 423 1530	02.21274 

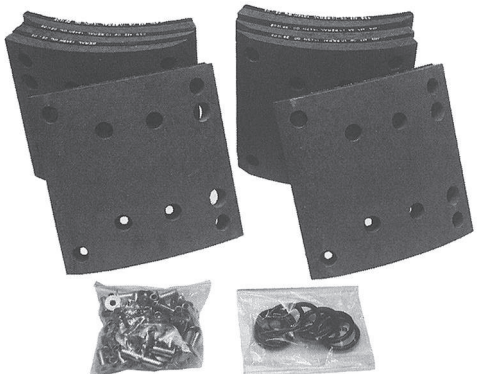
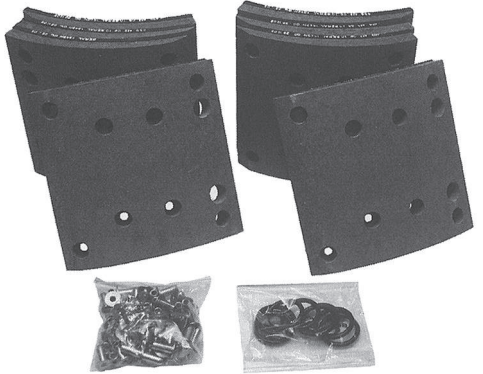
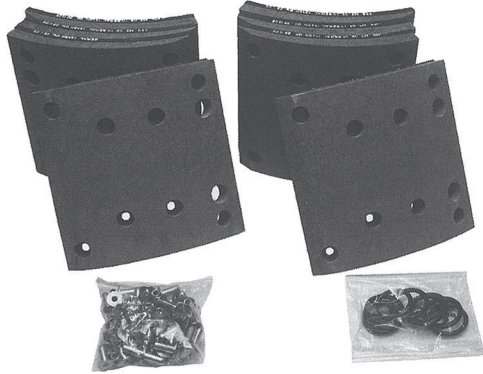

Sample

Sample







THE ORIGINAL NUMBERS OF THE VEHICLE MANUFACTURER MAY BE USED FOR COMPARISON PURPOSES ONLY AND MUST NOT BE MENTIONED ON INVOICES TO VEHICLE OWNERS.

Brake Drum





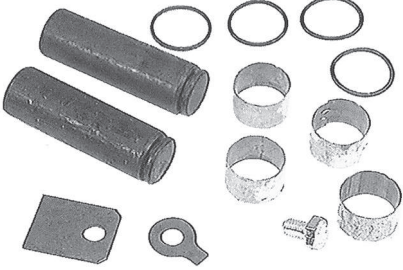

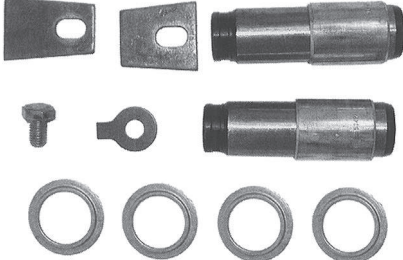
Bremstrommel • Tambour de frein • Tambor de freno
Tambor freio • Тормозной барабан

Application	Description	Details	Ref.	Erqo No.
740/748	<ul style="list-style-type: none"> EN Drum brake lining kit, axle kit DE Trommelbremsbelagsatz, Achssatz FR Jeu de garnitures de frein à tambour, Jeu d'essieu ES Juego de forros de freno de tambor PT Jogo tambor freio, Jogo de eixos RU Комплект тормозных накладок 	WVA 19496 - 18,0 mm / 220 mm	659 423 3610	02.21268 
				Sample
740/748	<ul style="list-style-type: none"> EN Drum brake lining kit, axle kit - oversize DE Trommelbremsbelagsatz, Achssatz - Übergröße FR Jeu de garnitures de frein à tambour, Jeu d'essieu - surdimensionné ES Juego de forros de freno de tambor, extragrandes PT Jogo tambor freio, Jogo de eixos - extra grande RU Комплект тормозных накладок - негабарит 	WVA 19496- 18,8 mm / 220 mm	659 423 3810	02.21269 
				Sample
730/731/733/739, 740/746/748/749	<ul style="list-style-type: none"> EN Repair kit, Brake shoe DE Reparatursatz, Bremsbacke FR Kit de réparation, mâchoire de frein ES Kit de reparación, Zapata de freno PT Jogo reparo, sapata freio RU Ремонтный комплект, Тормозная колодка 		307 420 0339	02.21232 
				
730/731/732/733, 739, 740/741/746/748, 749	<ul style="list-style-type: none"> EN Brake shoe bushing DE Bremsbackenbuchse FR Bague de mâchoire de frein ES Buje de zapata de freno PT Bucha comando RU Втулка тормозной колодки 	Ø 20 / 23 x 39 mm	620 421 0050	02.21251 
				

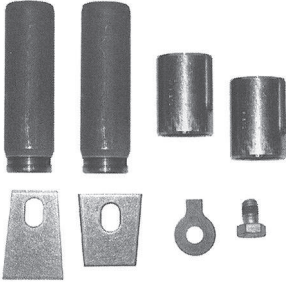

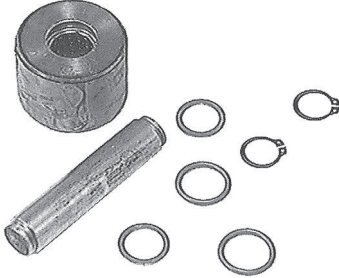







THE ORIGINAL NUMBERS OF THE VEHICLE MANUFACTURER MAY BE USED FOR COMPARISON PURPOSES ONLY AND MUST NOT BE MENTIONED ON INVOICES TO VEHICLE OWNERS.

Application	Description	Details	Ref.	Erqo No.
730/731/732/733, 739, 740/746/748/749	<p>EN Spring lock pin for brake shoe (welded version)</p> <p>DE Federhaltetestift für Bremsbacke (geschweißte Ausführung)</p> <p>FR Axe de blocage de ressort pour mâchoire de frein (version moulée)</p> <p>ES Espiga de sujeción del muelle para zapata freno (version soldada)</p> <p>PT Pino trava para patim de freio (versão aço)</p> <p>RU Штифт кронштейна рессоры для тормозных колодок (в сварном исполнении)</p>	Ø 12 x 97 mm	658 421 0074	02.21255 
				
730/731/733/739, 740/746/748/749	<p>EN Spring lock pin for brake shoe (casted version)</p> <p>DE Federhaltetestift für Bremsbacke (gegossene Ausführung)</p> <p>FR Axe de blocage de ressort pour mâchoire de frein (version acier)</p> <p>ES Espiga de bloqueo del muelle para zapata freno (version fundida)</p> <p>PT Pino trava para patim de freio (versão fundida)</p> <p>RU Штифт кронштейна рессоры для тормозных колодок (в литом исполнении)</p>	Ø 12 x 72 mm	945 421 0074	02.21256 
				
730/731/739, 740/746	<p>EN Repair kit old version</p> <p>DE Reparatursatz alte Ausführung</p> <p>FR Kit de réparation ancienne version</p> <p>ES Kit de reparación version antigua</p> <p>PT Jogo reparo versão antiga</p> <p>RU Ремонтный комплект старое исполнение</p>		395 420 0041	02.21236 
				
730/731/733/739, 740/746/748/749	<p>EN Repair kit, Brake shoe</p> <p>DE Reparatursatz, Bremsbacke</p> <p>FR Kit de réparation, mâchoire de frein</p> <p>ES Kit de reparación, Zapata de freno</p> <p>PT Jogo reparo, sapata freio</p> <p>RU Ремонтный комплект, Тормозная колодка</p>		307 420 4002	02.21194 
				



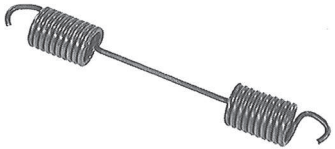







THE ORIGINAL NUMBERS OF THE VEHICLE MANUFACTURER MAY BE USED FOR COMPARISON PURPOSES ONLY AND MUST NOT BE MENTIONED ON INVOICES TO VEHICLE OWNERS.

Application	Description	Details	Ref.	Erqo No.
730/731/733/739, 740/746/748/749	<ul style="list-style-type: none"> EN Repair kit DE Reparatursatz FR Kit de réparation ES Kit de reparación PT Jogo reparo RU Ремонтный комплект 		307 420 4102	02.21195 
739, 749	<ul style="list-style-type: none"> EN Repair kit DE Reparatursatz FR Kit de réparation ES Kit de reparación PT Jogo reparo RU Ремонтный комплект 		335 420 0039	02.21233 
730/731/733/739, 740/746/748/749	<ul style="list-style-type: none"> EN Brake shoe pin included DE Bremsbackenbolzen enthalten FR Axe de mâchoire de frein compris dans ES Bulón de zapata de freno incluido PT Pino incluído na RU Опорный палец колодок тормозного механизма включено 	30 x 102 mm	497 421 0074	02.21254 
730/731/733/739, 740/746/748/749	<ul style="list-style-type: none"> EN Brake shoe bushing DE Bremsbackenbuchse FR Bague de mâchoire de frein ES Buje de zapata de freno PT Bucha comando RU Втулка тормозной колодки 	∅ 30 / 34 x 42 mm	307 421 0550	02.21249 
730/731/733/739, 740/746/748/749	<ul style="list-style-type: none"> EN Lock plate DE Sicherungsblech FR Tôle de fixation ES Chapa de seguridad PT Trava caixa RU Стопорная шайба 	44 x 32 x 3,5 mm	381 994 0009	02.22561 

THE ORIGINAL NUMBERS OF THE VEHICLE MANUFACTURER MAY BE USED FOR COMPARISON PURPOSES ONLY AND MUST NOT BE MENTIONED ON INVOICES TO VEHICLE OWNERS.

Application	Description	Details	Ref.	Erqo No.
730/731/733/739, 740/746/748/749	<ul style="list-style-type: none"> EN Lock plate DE Sicherungsblech FR Tôle de fixation ES Chapa de seguridad PT Trava caixa RU Стопорная шайба 	54 x 28 x 3,5 mm	346 994 0109	02.22560 
				
NG/MK/SK	<ul style="list-style-type: none"> EN Spring DE Feder FR Ressort ES Muelle PT Mola RU Пружина 	L = 245 mm	617 993 1110	02.22554 
				
NG/MK/SK	<ul style="list-style-type: none"> EN Spring DE Feder FR Ressort ES Muelle PT Mola RU Пружина 	L = 235 mm	346 993 0310	02.22546 
				
NG/MK/SK	<ul style="list-style-type: none"> EN Spring DE Feder FR Ressort ES Muelle PT Mola RU Пружина 	L = 228 mm	346 993 0810	02.22547 
				
NG/MK/SK	<ul style="list-style-type: none"> EN Spring DE Feder FR Ressort ES Muelle PT Mola RU Пружина 	L = 232 mm	945 993 0010	02.22557 
				
V 730/731/739 H 740/742/744/745, 748/770/771	<ul style="list-style-type: none"> EN Wear indicator DE Verschleißanzeige FR Témoin d'usure ES Indicador de desgaste PT Indicador desgaste RU Указатель износа 	Ø 18,9 mm	677 540 0717	02.21878 
				

THE ORIGINAL NUMBERS OF THE VEHICLE MANUFACTURER MAY BE USED FOR COMPARISON PURPOSES ONLY AND MUST NOT BE MENTIONED ON INVOICES TO VEHICLE OWNERS.

Application	Description	Details	Ref.	Erqo No.
V 730/731/739 H 740/742/744/745, 748/770/771	<ul style="list-style-type: none"> EN Wear indicator DE Verschleißanzeige FR Témoin d'usure ES Indicador de desgaste PT Indicador desgaste RU Указатель износа 	Ø 16,9 mm	677 540 0817	02.21879 
				
H 741	<ul style="list-style-type: none"> EN Wear indicator DE Verschleißanzeige FR Témoin d'usure ES Indicador de desgaste PT Indicador desgaste RU Указатель износа 		601 540 0617	02.21872 
				
H 741/742	<ul style="list-style-type: none"> EN Wear indicator DE Verschleißanzeige FR Témoin d'usure ES Indicador de desgaste PT Indicador desgaste RU Указатель износа 		670 540 0017	02.21877 
				
H 740/748/749	<ul style="list-style-type: none"> EN ABS sensor, left DE ABS Sensor, links FR Capteur ABS, gauche ES Sensor de ABS, Izquierdo PT Sensor ABS, esquerdo RU Датчик ABS, лев. 		655 540 0817	02.21876 
				Sample
H 740/748/749	<ul style="list-style-type: none"> EN ABS sensor, right DE ABS Sensor, rechts FR Capteur ABS, droit ES Sensor de ABS, derecho PT Sensor ABS, direito RU Датчик ABS, прав. 		655 540 0717	02.21875 
				Sample







THE ORIGINAL NUMBERS OF THE VEHICLE MANUFACTURER MAY BE USED FOR COMPARISON PURPOSES ONLY AND MUST NOT BE MENTIONED ON INVOICES TO VEHICLE OWNERS.

Brake DrumBremstrommel • Tambour de frein • Tambor de freno
Tambor freio • Тормозной барабан

Application	Description	Details	Ref.	Erqo No.
V 730, H 740/745/748/749	<ul style="list-style-type: none">EN BushingDE BuchseFR ArrêtoirES SeguroPT VuchaRU Втулка		355 542 0273	02.21925 



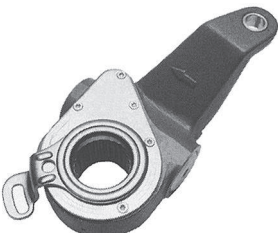

Slack Adjuster

Gestängesteller • Levier régléur • Biela/ Palanca de freno
Ajustador de freio • регулятор зазора тормозных колодок







Application	Description	Details	Ref.	Erqo No.
VL 4 / ... (BM 739)	<ul style="list-style-type: none"> EN Slack adjuster front axle DE Gestängesteller Vorderachse FR Levier régléur essieu avant ES Palanca de freno eje delantero PT Catraca freio eixo da frente RU Трещетка передняя ось 	repl. Wabco 433 506 103 0	000 420 0438	02.21204 
				
HL II...; HD 7 / ... (BM 740/748)	<ul style="list-style-type: none"> EN Slack adjuster rear axle DE Gestängesteller Hinterachse FR Levier régléur essieu arrière ES Palanca de freno eje trasero PT Catraca freio eixo traseiro RU Трещетка задняя ось 	repl. Wabco 433 506 514 0	346 420 1738	02.21205 
				
HL II...; HD 7 / ... (BM 740/748)	<ul style="list-style-type: none"> EN Slack adjuster, manual rear axle DE Gestängesteller, manuell Hinterachse FR Levier régléur, manuel essieu arrière ES Palanca manual de freno eje trasero PT Catraca freio, manual eixo traseiro RU Трещетка, ручной задняя ось 	repl. Wabco 433 506 515 0	346 420 1838	02.21206 
				
HL 7 / ...; HD 7 / ... (BM 740/746/748)	<ul style="list-style-type: none"> EN Slack adjuster, automatic DE Gestängesteller, automatisch FR Levier régléur, Automatique ES Palanca automática de freno PT Catraca freio, automática RU Трещетка, автоматический 	repl. Haldex 80001C	945 420 0338	02.21227 
				

Sample

THE ORIGINAL NUMBERS OF THE VEHICLE MANUFACTURER MAY BE USED FOR COMPARISON PURPOSES ONLY AND MUST NOT BE MENTIONED ON INVOICES TO VEHICLE OWNERS.

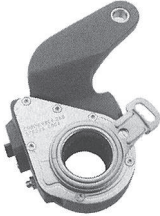
Application	Description	Details	Ref.	Erqo No.
HL 7/...; HD 7/... (B M 740/746/748)	EN Slack adjuster, automatic left - rear axle DE Gestängesteller, automatisch links - Hinterachse FR Levier régléur, Automatique gauche - essieu arrière ES Palanca automática de freno izquierdo - eje trasero PT Catraca freio, automática esquerdo - eixo traz RU Трещетка, автоматический левый - задняя ось	repl. Haldex 70952	945 420 0238	02.21226 
				
HL 7/...; HD 7/... (BM 740/746/748)	EN Slack adjuster, automatic right - rear axle DE Gestängesteller, automatisch rechts - Hinterachse FR Levier régléur, Automatique droit - essieu arrière ES Palanca automática de freno derecho - eje trasero PT Catraca freio, automática, direita direito - eixo traz RU Трещетка, автоматический правый - задняя ось	repl. Haldex 70953	617 420 0238	02.21209 
				
VL 4 / VL 5 / ... (BM 739)	EN Slack adjuster, automatic left - front axle DE Gestängesteller, automatisch links - Vorderachse FR Levier régléur, Automatique gauche - essieu avant ES Palanca automática de freno izquierdo - eje delantero PT Catraca freio, automática esquerdo - eixo da frente RU Трещетка, автоматический левый - передняя ось	repl. Haldex 80008	945 420 0038	02.21224 
				
VL 4 / VL 5 / ... (BM 739)	EN Slack adjuster, automatic right - front axle DE Gestängesteller, automatisch rechts - Vorderachse FR Levier régléur, Automatique droit - essieu central ES Palanca automática de freno derecho - eje delantero PT Catraca freio, automática direito - eixo da frente RU Трещетка, автоматический правый - передняя ось	repl. Haldex 80009	945 420 0138	02.21225 
				



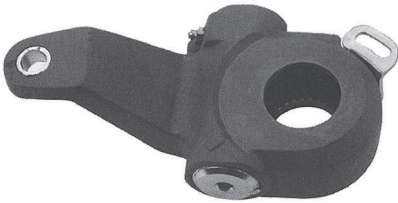



THE ORIGINAL NUMBERS OF THE VEHICLE MANUFACTURER MAY BE USED FOR COMPARISON PURPOSES ONLY AND MUST NOT BE MENTIONED ON INVOICES TO VEHICLE OWNERS.

Application	Description	Details	Ref.	Erqo No.
VL 4 /... (BM 733/739)	<ul style="list-style-type: none"> EN Slack adjuster, automatic front axle DE Gestängesteller, automatisch Vorderachse FR Levier régléur, Automatique essieu avant ES Palanca automática de freno eje delantero PT Catraca freio, automática eixo frente RU Трещетка, автоматический передней оси 	repl. Haldex 72062	619 420 0038	02.21211 
				
VL4/... (BM 733/739)	<ul style="list-style-type: none"> EN Slack adjuster, automatic front axle DE Gestängesteller, automatisch Vorderachse FR Levier régléur, Automatique essieu avant ES Palanca automática de freno eje delantero PT Catraca freio, automática eixo frente RU Трещетка, автоматический передней оси 	repl. Haldex 72063	619 420 0138	02.21213 
				
HL 7/...; HD 7/... (BM 740/748)	<ul style="list-style-type: none"> EN Slack adjuster, automatic rear axle DE Gestängesteller, automatisch Hinterachse FR Levier régléur, Automatique essieu arrière ES Palanca automática de freno eje trasero PT Catraca freio, automática eixo traseiro RU Трещетка, автоматический задней оси 	repl. Haldex 72173	387 420 0038	02.21207 
				
HL 7/...; HD 7/... (BM 740/748)	<ul style="list-style-type: none"> EN Slack adjuster, automatic rear axle DE Gestängesteller, automatisch Hinterachse FR Levier régléur, Automatique essieu arrière ES Palanca automática de freno eje trasero PT Catraca freio, automática eixo traseiro RU Трещетка, автоматический задней оси 	repl. Haldex 72174	387 420 0138	02.21208 
				

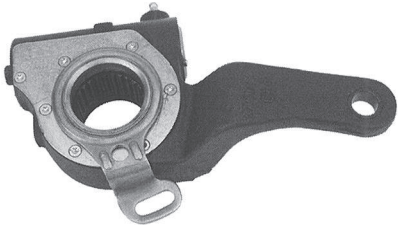
THE ORIGINAL NUMBERS OF THE VEHICLE MANUFACTURER MAY BE USED FOR COMPARISON PURPOSES ONLY AND MUST NOT BE MENTIONED ON INVOICES TO VEHICLE OWNERS.

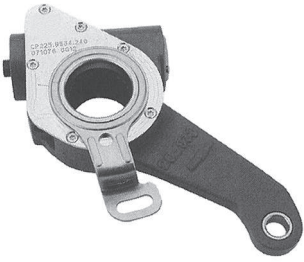

Slack Adjuster

Gestängesteller • Levier régléur • Biela/ Palanca de freno
 Ajustador de freio • регулятор зазора тормозных колодок





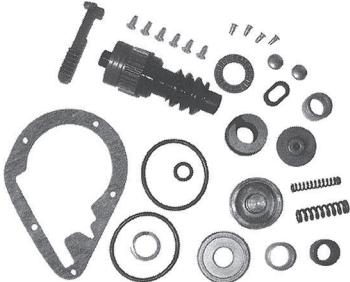

Application	Description	Details	Ref.	Erqo No.
AL 3 /... (BM 731/733)	<ul style="list-style-type: none"> EN Slack adjuster, automatic front axle DE Gestängesteller, automatisch Vorderachse FR Levier régléur, Automatique essieu avant ES Palanca automática de freno eje delantero PT Catraca freio, automática eixo frente RU Трещетка, автоматический передней оси 	repl. Haldex 80012	945 420 0538	02.21228 
				
AL 3 /... (BM 731/733)	<ul style="list-style-type: none"> EN Slack adjuster, automatic front axle DE Gestängesteller, automatisch Vorderachse FR Levier régléur, Automatique essieu avant ES Palanca automática de freno eje delantero PT Catraca freio, automática eixo frente RU Трещетка, автоматический передней оси 	repl. Haldex 80013	945 420 0638	02.21229 
				
				Sample
VL 4 /... (BM 733/739)	<ul style="list-style-type: none"> EN Slack adjuster, automatic front axle DE Gestängesteller, automatisch Vorderachse FR Levier régléur, Automatique essieu avant ES Palanca automática de freno eje delantero PT Catraca freio, automática eixo frente RU Трещетка, автоматический передней оси 	repl. Haldex 70867	620 420 0338	02.21214 
				
HL 4 /... (BM 745/746)	<ul style="list-style-type: none"> EN Slack adjuster, automatic DE Gestängesteller, automatisch FR Levier régléur, Automatique ES Palanca automática de freno PT Catraca freio, automática RU Трещетка, автоматический 	repl. Haldex 8001 OC	945 420 0838	02.21231 
				
				Sample

Slack Adjuster

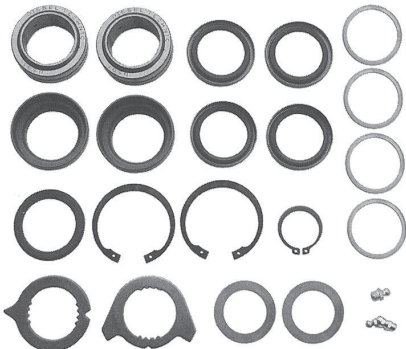
Gestängesteller • Levier régléur • Biela/ Palanca de freno
 Ajustador de freio • регулятор зазора тормозных колодок



Application	Description	Details	Ref.	Erqo No.
HL 4 / ... (BM 745/746)	EN Slack adjuster, automatic DE Gestängesteller, automatisch FR Levier régléur, Automatique ES Palanca automática de freno PT Catraca freio, automática RU Трещетка, автоматический	repl. Haldex 80011C	945 420 0738	02.21230 
				
				Sample
NG/MK/SK	EN Slack adjuster kit DE Gestängestellersatz FR Kit levier régléur ES Juego regulador de transmision PT Reparo catraca freio RU Комплект трещеток		000 420 0092	02.21240 
				

Application	Description	Details	Ref.	Erqo No.
HL 7/...; HD 7/... (BM 740/745/746/748)	<ul style="list-style-type: none"> EN Brake camshaft, left rear axle DE Bremsnockenwelle, links Hinterachse FR Arbre à cames frein, gauche essieu arrière ES Eje de leva de freno, izquierdo eje trasero PT Veio travão, esquerdo eixo traseiro RU Вал колёсного тормоза, лев. задней оси 		623 423 0136	02.21278 
HL7/...; HD 7/... (BM 740/745/746/748)	<ul style="list-style-type: none"> EN Brake camshaft, right rear axle DE Bremsnockenwelle, rechts Hinterachse FR Arbre à cames frein, droite essieu arrière ES Eje de leva de freno, derecho eje trasero PT Velo travão, direito eixo traseiro RU Вал колёсного тормоза, прав. задней оси 		623 423 0236	02.21279 
VL 3 / VL 4 / ... VL 5 / ... (BM 730/732/733/739)	<ul style="list-style-type: none"> EN Brake camshaft, left DE Bremsnockenwelle, links FR Arbre à cames frein, gauche ES Leva freno, izquierdo PT Veio travão, esquerdo RU Вал разжимного кулака, левый 		623 421 0136	02.21246 
VL 3 / VL 4 / ... VL 5 / ... (BM 730/732/733/739)	<ul style="list-style-type: none"> EN Brake camshaft, right DE Bremsnockenwelle, rechts FR Arbre à cames frein, droit ES Leva freno, derecho PT Veio travão, direito RU Вал разжимного кулака, правый 		623 421 0236	02.21247 

Application	Description	Details	Ref.	Erqo No.
HL 7/...; HD 7/... (BM 740/748) -- axle 098310	<ul style="list-style-type: none"> EN Repair kit, brake camshaft DE Reparatursatz, Bremsnockenwelle FR Kit de réparation, came de frein ES Kit de reparación, Eje de leva de freno PT Jogo reparo, catraca freio RU Ремонтный комплект, Вал разжимного кулака 		360 420 0341	02.21234 
HL 4/...; HD 4/... (BM 745/746), HL 7...; HD 7... (BM 740/748) axle 098311--	<ul style="list-style-type: none"> EN Repair kit, brake camshaft DE Reparatursatz, Bremsnockenwelle FR Kit de réparation, came de frein ES Kit de reparación, Eje de leva de freno PT Jogo reparo, catraca freio RU Ремонтный комплект, Вал разжимного кулака 		360 420 0441	02.21235 
VL 4 /... (BM 739), HL 4 / HD 4 /... (BM 746)	<ul style="list-style-type: none"> EN Bushing DE Buchse FR Bague ES Casquillo PT Bucha RU Втулка 	42 x 48 x 49 mm	305 421 0750	02.21248 
NR 4/...; NS 4/... HD 6 /... (BM 745/749)	<ul style="list-style-type: none"> EN Brake shoe bushing DE Bremswellenbuchse FR Bague de mâchoire de frein ES Buje del árbol de freno PT Bucha comando RU Втулка вала разжимного колеса 	Ø 42 / 48 x 45 mm	335 421 0250	02.21250 

Brake Camshaft

Bremsnockenwelle • Axe de came de frein • Eje de leva de freno
 Eixo excêntrico • Вал разжимного кулака колёсного

Application	Description	Details	Ref.	Erqo No.
HD 6/... (BM 745)	<ul style="list-style-type: none"> EN Brake shoe bushing DE Bremswellenbuchse FR Bague de mâchoire de frein ES Buje del árbol de freno PT Bucha comando RU Втулка вала разжимного колеса 	Ø 38 / 42 x 30 mm	304 423 0050	02.21280 
VL 3 / V O 3/... VL 4 / ...; VO4/... AL 7 / ...; VL 7 / ... BM (730/731/732/739); HL 4/...; HD 4/... HL7/...; HD 7 /... BM (740/743/745/746, 748/749)	<ul style="list-style-type: none"> EN Bushing, brake camshaft DE Buchse, Bremsnockenwelle FR Bague, Axe de came de frein ES Casquillo, Eje de leva de freno PT Bucha, eixo excêntrico RU Втулка, Вал разжимного кулака 	42 x 48 x 32 mm	658 421 0150	02.21252 



Brake CylinderBremszylinder • Cylindre de frein • Actuador/ Pulmón de freno
Câmara de freio • Тормозной цилиндр

Application	Description	Details	Ref.	Erqo No.
VL 3 /...; VL 4 /...; VL 7 /...	<ul style="list-style-type: none"> EN Brake cylinder, T 20 DE Bremszylinder, T 20 FR Cylindre de frein, T 20 ES Pulmón de freno, T 20 PT Cuica freio, T 20 RU Тормозной цилиндр, Т 2 0 	repl. Wabco 423 205 103 0	007 420 8718	02.21197











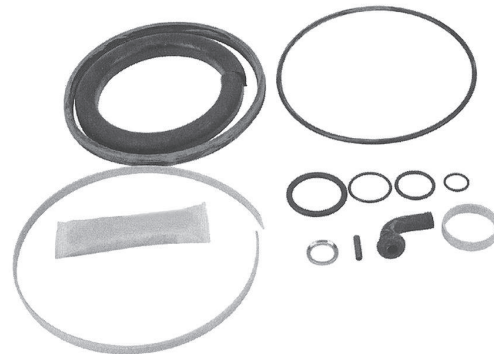

Sample

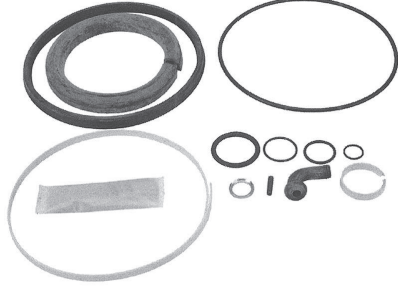
BPW 02.032.72.90.0	<ul style="list-style-type: none"> EN Brake cylinder DE Bremszylinder FR Cylindre de frein ES Pulmón de freno PT Cuica freio RU Тормозной цилиндр 	repl. Wabco 423 107 900 0	699 420 0724	02.23217
-----------------------	---	---------------------------	--------------	----------













NG/MK/SK	<ul style="list-style-type: none"> EN Repair kit, brake cylinder DE Reparatursatz, Bremszylinder FR Kit de réparation, cylindre de frein ES Kit de reparación, Cilindro de freno PT Jogo reparo, Cuica freio RU Ремонтный комплект, тормозной цилиндр 	repl. Wabco: 925 321 001 2	002 430 1560	02.21375
----------	---	----------------------------	--------------	----------



Application	Description	Details	Ref.	Erqo No.
NG/MK/SK	<ul style="list-style-type: none"> EN Repair kit, brake cylinder DE Reparatursatz, Bremszylinder FR Kit de réparation, cylindre de frein ES Kit de reparación, Cilindro de freno PT Jogo reparo, Cuica freio RU Ремонтный комплект, тормозной цилиндр 	repl. Wabco: 925 320 002 2	005 420 5424	02.21203 
				
NG/MK/SK	<ul style="list-style-type: none"> EN Diaphragm, T 9 DE Membrane, T 9 FR Membrane, T 9 ES Membrana, T 9 PT Diafragma, T 9 RU Мембрана, Т 9 	repl. Wabco: 897 120 495 4	000 144 0028	02.23218 
				
NG/MK/SK	<ul style="list-style-type: none"> EN Diaphragm, T 12 DE Membrane, T 12 FR Membrane, T 12 ES Membrana, T 12 PT Diafragma, T 12 RU Мембрана, Т 12 	repl. Wabco: 897 120 505 4	000 431 1728	02.23219 
				
NG/MK/SK	<ul style="list-style-type: none"> EN Diaphragm, T16 DE Membrane, T 16 FR Membrane, T 16 ES Membrana, T 16 PT Diafragma, T 16 RU Мембрана, Т 16 	repl. Wabco: 897 120 510 4	000 421 2986	02.23220 
				
NG/MK/SK	<ul style="list-style-type: none"> EN Diaphragm, T 20 DE Membrane, T 20 FR Membrane, T 20 ES Membrana, T 20 PT Diafragma, T 20 RU Мембрана, Т 20 	repl. Wabco: 897 120 520 4	897 120 5204	02.23221 
				

THE ORIGINAL NUMBERS OF THE VEHICLE MANUFACTURER MAY BE USED FOR COMPARISON PURPOSES ONLY AND MUST NOT BE MENTIONED ON INVOICES TO VEHICLE OWNERS.

Brake CylinderBremszylinder • Cylindre de frein • Actuador/ Pulmón de freno
Câmara de freio • Тормозной цилиндр

Application	Description	Details	Ref.	Erqo No.
NG/MK/SK	<ul style="list-style-type: none"> EN Diaphragm, T 24 DE Membrane, T 24 FR Membrane, T 24 ES Membrana, T 24 PT Diafragma, T 24 RU Мембрана, Т 24 	repl.Wabco 897 120 530 4	000 421 2086	02.21257 
				
NG/MK/SK	<ul style="list-style-type: none"> EN Diaphragm, T 30 DE Membrane, T 30 FR Membrane, T 30 ES Membrana, T 30 PT Diafragma, T 30 RU Мембрана, Т 30 	repl. Wabco: 897 120 540 4	000 423 1286	02.23222 
				
NG/MK/SK	<ul style="list-style-type: none"> EN Diaphragm, T 36 DE Membrane, T 36 FR Membrane, T 36 ES Membrana, T 36 PT Diafragma, T 36 RU Мембрана, Т 36 	repl. Wabco: 897 120 550 4		02.23223 
				
NG/MK/SK	<ul style="list-style-type: none"> EN Diaphragm, long - T 16 DE Membrane, lang - T 16 FR Membrane, longue - T 16 ES Membrana, curso largo - T 16 PT Diafragma, longo - T 16 RU Мембрана, длинная - Т 16 	repl.Wabco: 897 120 515 4	000 431 2028	02.23224 
				
NG/MK/SK	<ul style="list-style-type: none"> EN Diaphragm, long - T 20 DE Membrane, lang - T 20 FR Membrane, longue - T 20 ES Membrana, curso largo - T 20 PT Diafragma, longo - T 20 RU Мембрана, длинная - Т 20 	repl.Wabco: 897 120 526 4	000 421 4286	02.23225 
				

THE ORIGINAL NUMBERS OF THE VEHICLE MANUFACTURER MAY BE USED FOR COMPARISON PURPOSES ONLY AND MUST NOT BE MENTIONED ON INVOICES TO VEHICLE OWNERS.

Brake Cylinder

Bremszylinder • Cylindre de frein • Actuador/ Pulmón de freno
Câmara de freio • Тормозной цилиндр

Application	Description	Details	Ref.	Erqo No.
NG/MK/SK	<ul style="list-style-type: none"> EN Diaphragm, long-T 24 DE Membrane, lang - T 24 FR Membrane, longue - T 24 ES Membrana, curso largo - T 24 PT Diafragma, longo - T 24 RU Мембрана, длинная - T 24 	repl. Wabco: 897 120 536 4	000 431 1928	02.23226



NG/MK/SK	<ul style="list-style-type: none"> EN Diaphragm, long - T 30 DE Membrane, lang - T 30 FR Membrane, longue - T 30 ES Membrana, curso largo - T 30 PT Diafragma, longo - T 30 RU Мембрана, длинная - T 30 	wabc no: 897 120 546 4	000 421 6286	02.23227
----------	---	------------------------	--------------	----------



7

BM 385	<ul style="list-style-type: none"> EN Master cylinder DE Hauptzylinder FR Cylindre principal ES Cilindro principal PT Cilindro mestre RU Главный цилиндр 	Ø 34,8 mm	002 430 4101	02.21347
--------	--	-----------	--------------	----------

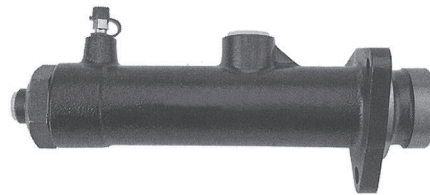



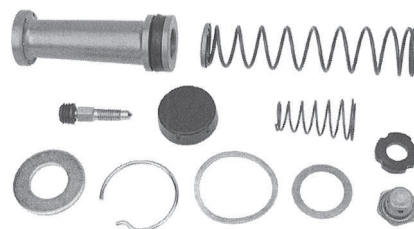



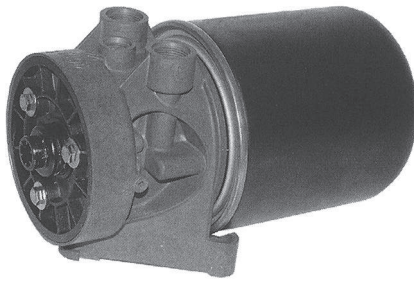

BM 385	<ul style="list-style-type: none"> EN Repair kit DE Reparatursatz FR Kit de réparation ES Kit de reparación PT Jogo reparo RU Ремонтный комплект 		000 586 1743	02.22094
--------	--	--	--------------	----------





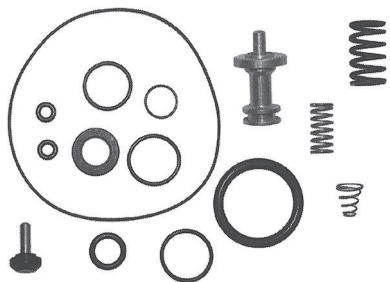

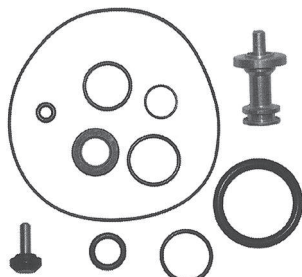





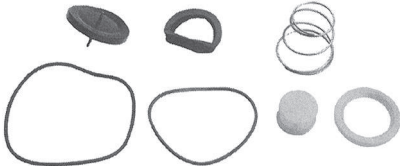

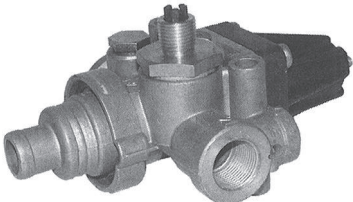

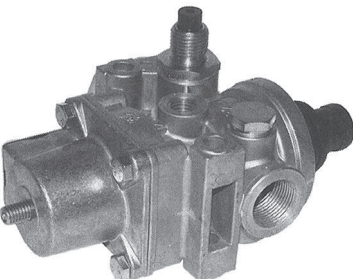

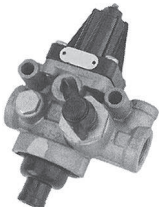

THE ORIGINAL NUMBERS OF THE VEHICLE MANUFACTURER MAY BE USED FOR COMPARISON PURPOSES ONLY AND MUST NOT BE MENTIONED ON INVOICES TO VEHICLE OWNERS.

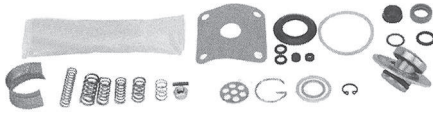
Air Dryer & GovernorLufttrockner & Druckregler • Dessiccateur • Secador de Aire & Governor
Filtro Secador & Válvula • Влагоотделитель и регулятор давления

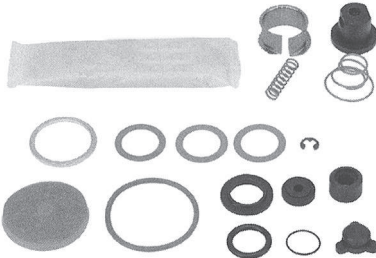
Application	Description	Details	Ref.	Erqo No.
BM 625, 650/651/652/653, 654/655/656/658, 659	<ul style="list-style-type: none"> EN Air dryer DE Lufttrockner FR Dessiccateur d'air ES Secador de aire PT Secador ar RU Влагоотделитель 	repl. Wabco 432 421 008 0	001 431 0415	02.21497 
				
BM 625, 650/651/652/653, 654/655/656/658, 659	<ul style="list-style-type: none"> EN Air dryer cartridge DE Lufttrocknerpatrone FR Cartouche de dessiccateur ES Cartucho del secador de aire PT Elemento secador ar RU Патрон влагоотделителя 	repl. Knorr I1401 00F	000 429 3695	02.21346 
				
BM 625, 650/651/652/653, 654/655/656/658, 659	<ul style="list-style-type: none"> EN Air dryer kit DE Lufttrocknersatz FR Kit dessiccateur ES Juego de secador de aire PT Jogo reparo filtro secador RU Комплект влагоотделителя 	repl. Wabco 432 410 000 2	001 430 8360	02.21373 
				
BM 625, 650/651/652/653, 654/655/656/658, 659	<ul style="list-style-type: none"> EN Air dryer kit DE Lufttrocknersatz FR Kit dessiccateur ES Juego de secador de aire PT Jogo reparo filtro secador RU Комплект влагоотделителя 	repl. Knorr I90121	001 430 9660	02.21374 
				
BM 625, 650/651/652/653, 654/655/656/658, 659	<ul style="list-style-type: none"> EN Air dryer kit DE Lufttrocknersatz FR Kit dessiccateur ES Juego de secador de aire PT Jogo reparo filtro secador RU Комплект влагоотделителя 	repl. Knorr I851390051	002 430 3160	02.21379 
				

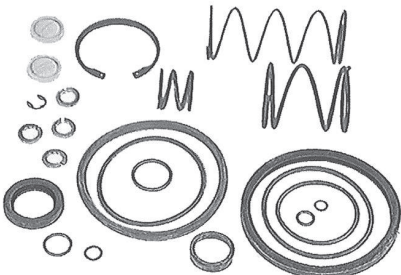

THE ORIGINAL NUMBERS OF THE VEHICLE MANUFACTURER MAY BE USED FOR COMPARISON PURPOSES ONLY AND MUST NOT BE MENTIONED ON INVOICES TO VEHICLE OWNERS.

Application	Description	Details	Ref.	Erqo No.
BM 615/616/617/619, 620/621/622/623, 624/625	<ul style="list-style-type: none"> EN Air filter, brake DE Luftfilter, Bremse FR Filtre à air, Freins ES Filtro de aire, freno PT Elemento filtro ar, freio RU Воздушный фильтр, Тормоз 	repl. Wabco 432 511 000 0	000 429 2595	02.21342 
				
BM 615/616/617/619, 620/621/622/623, 624/625	<ul style="list-style-type: none"> EN Repair kit, air filter DE Reparatursatz, Luftfilter FR Kit de réparation, Filtre à air ES Kit de reparación, Filtro de aire PT Jogo reparo, filtro ar RU Ремонтный комплект, Воздушный фильтр 	repl. Wabco 432 511 000 2	000 420 4455	02.21237 
				
BM 625, 650/651/652/653, 654/655/656/657, 658/659	<ul style="list-style-type: none"> EN Pressure valve DE Druckventil FR Contacteur de pression ES Válvula de alimentación PT Válvula pressão RU Нагнетательный клапан 	repl. Wabco 975 300 474 0	002 431 4606	02.21467 
				
BM 645/647, 651/652/653/654, 655/656/657/658	<ul style="list-style-type: none"> EN Governor DE Druckregler FR Régulateur de pression ES Regulador de presión PT Válvula pressão RU Регулятор давления 	repl. Knorr 0 481 039 213	002 431 4706	02.21468 
				
BM 380/381/383, 385/387/389, 393/395, 615/616/617/619, 620/621/622/623, 624/625	<ul style="list-style-type: none"> EN Governor DE Druckregler FR Régulateur de pression ES Regulador de presión PT Válvula pressão RU Регулятор давления 	repl. Wabco 975 303 473 0	002 431 4906	02.21469 
				

Application	Description	Details	Ref.	Erqo No.
5 S-111	<ul style="list-style-type: none"> EN Repair kit DE Reparatursatz FR Kit de réparation ES Kit de reparación PT Jogo reparo RU Ремонтный комплект 	repl. Wabco 975 300 000 2	000 430 1107	02.21356 
				
NG/MK/SK	<ul style="list-style-type: none"> EN Repair kit DE Reparatursatz FR Kit de réparation ES Kit de reparación PT Jogo reparo RU Ремонтный комплект 	repl. Wabco 975 303 001 2	001 430 4960	02.21372 
				
NG/MK/SK	<ul style="list-style-type: none"> EN Repair kit DE Reparatursatz FR Kit de réparation ES Kit de reparación PT Jogo reparo RU Ремонтный комплект 	repl. Knorr I 487 010 102	000 430 1768	02.21382 
				
NG/MK/SK	<ul style="list-style-type: none"> EN Repair kit DE Reparatursatz FR Kit de réparation ES Kit de reparación PT Jogo reparo RU Ремонтный комплект 	repl. Wabco 471 401 009 2	000 586 6743	02.22095 
				
NG/MK/SK	<ul style="list-style-type: none"> EN Repair kit DE Reparatursatz FR Kit de réparation ES Kit de reparación PT Jogo reparo RU Ремонтный комплект 	repl. Knorr I 487 010 165	000 430 0907	02.21355 
				





THE ORIGINAL NUMBERS OF THE VEHICLE MANUFACTURER MAY BE USED FOR COMPARISON PURPOSES ONLY AND MUST NOT BE MENTIONED ON INVOICES TO VEHICLE OWNERS.







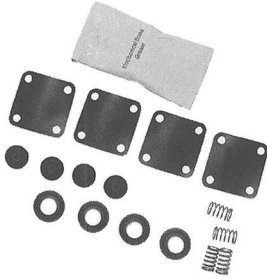

Air Dryer & GovernorLufttrockner & Druckregler • Dessiccateur • Secador de Aire & Governor
Filtro Secador & Válvula • Влагоотделитель и регулятор давления

Application	Description	Details	Ref.	Erqo No.
BM 387/389, BM 393/395 (--Chassis 4 191895)	<ul style="list-style-type: none">EN Brake hoseDE BremsschlauchFR Durite de freinES Tubo flexible de frenoPT Flexível freioRU Тормозной шланг	L: 310 mm	000 429 7335	02.21316 
BM 387/389, BM 393/395 (chassis 4 191896--)	<ul style="list-style-type: none">EN Brake hoseDE BremsschlauchFR Flexible de freinES Tubo flexible de frenoPT Flexível freioRU Тормозной шланг	L: 500 mm	000 429 7135	02.21315 

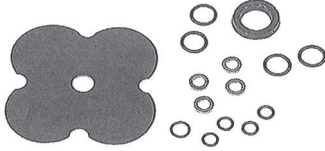

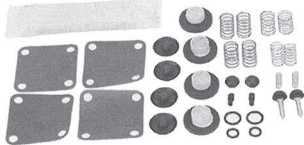
Protection ValveSchutzventil • Valve Protection • Válvula de Seguridad
Válvula de Proteção • Защитный клапан

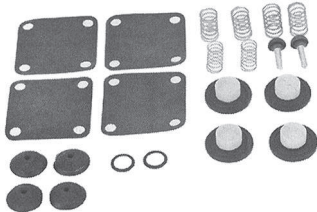

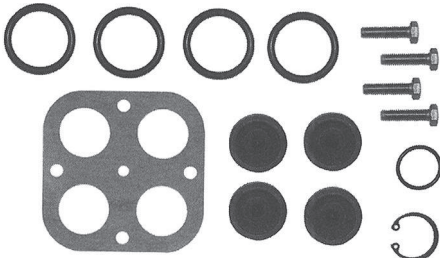



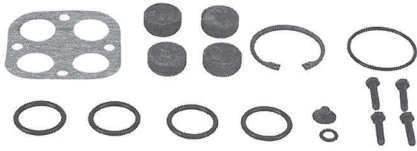

Application	Description	Details	Ref.	Erqo No.
BM 650/651/652/653, 654/655/656/657, 658/659	<ul style="list-style-type: none"> EN 4-circuit-protection valve DE 4-Kreis-Schutzventil FR Valve de protection 4 voies ES Válvula de seguridad de 4 circuitos PT Válvula proteção, 4 circuitos RU Предохранительный клапан 	repl. Knorr AE4404	003 431 4706	02.21483 
BM 387/389, 391/393/395	<ul style="list-style-type: none"> EN 4-circuit-protection valve DE 4-Kreis-Schutzventil FR Valve de protection 4 voies ES Válvula de seguridad de 4 circuitos PT Válvula proteção, 4 circuitos RU Предохранительный клапан 	repl. Wabco 934 702 300 0	001 431 3006	02.21443 
BM 615/616/617/618, 619, 620/621/622/623, 624/625, 645/646/647/648, 649	<ul style="list-style-type: none"> EN 4-circuit-protection valve DE 4-Kreis-Schutzventil FR Valve de protection 4 voies ES Válvula de seguridad de 4 circuitos PT Válvula proteção, 4 circuitos RU Предохранительный клапан 	repl. Wabco 934 702 250 0	002 431 4006	02.21465 
BM 380/381/383/385, 387/389, 393/395, 620/621/623/624	<ul style="list-style-type: none"> EN 4-circuit-protection valve DE 4-Kreis-Schutzventil FR Valve de protection 4 voies ES Válvula de seguridad de 4 circuitos PT Válvula proteção, 4 circuitos RU Предохранительный клапан 	repl. Wabco 934 702 210 0	002 431 0406	02.21461 

Application	Description	Details	Ref.	Erqo No.
NG/MK/SK	<ul style="list-style-type: none"> EN Repair kit, 4-circuit-protection valve DE Reparatursatz, 4-Kreis-Schutzventil FR Kit de réparation, valve de protection 4 voies ES Kit de reparación, válvula de seguridad de 4 circuitos PT Jogo reparo, válvula proteção 4circuitos RU Ремонтный комплект, Предохранительный клапан 	repl. Wabco 934 901 005 2	003 586 0943	02.22108 
				
NG/MK/SK	<ul style="list-style-type: none"> EN Repair kit, 4-circuit-protection valve DE Reparatursatz, 4-Kreis-Schutzventil FR Kit de réparation, valve de protection 4 voies ES Kit de reparación, válvula de seguridad de 4 circuitos PT Jogo reparo, válvula proteção 4 circuitos RU Ремонтный комплект, Предохранительный клапан 	repl. Knorr 180448	003 586 1043	02.22109 
				
NG/MK/SK	<ul style="list-style-type: none"> EN Repair kit DE Reparatursatz FR Kit de réparation ES Kit de reparación PT Jogo reparo RU Ремонтный комплект 	repl. Wabco 934 702 005 2	002 586 2843	02.22099 
				
NG/MK/SK	<ul style="list-style-type: none"> EN Repair kit DE Reparatursatz FR Kit de réparation ES Kit de reparación PT Jogo reparo RU Ремонтный комплект 	repl. Wabco 934 702 009 2	000 430 0468	02.21380 
				
NG/MK/SK	<ul style="list-style-type: none"> EN Repair kit, 4-circuit-protection valve DE Reparatursatz, 4-Kreis-Schutzventil FR Kit de réparation, valve de protection 4 voies ES Kit de reparación, válvula de seguridad de 4 circuitos PT Jogo reparo, válvula proteção 4 circuitos RU Ремонтный комплект, Предохранительный клапан 	repl. Knorr 1 487 010 237	000 430 4706	02.21353 
				

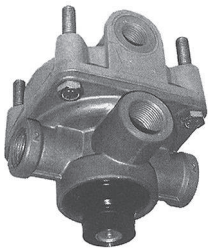
THE ORIGINAL NUMBERS OF THE VEHICLE MANUFACTURER MAY BE USED FOR COMPARISON PURPOSES ONLY AND MUST NOT BE MENTIONED ON INVOICES TO VEHICLE OWNERS.

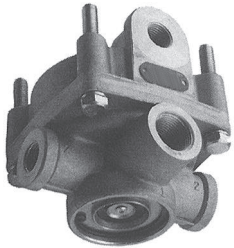
Protection Valve

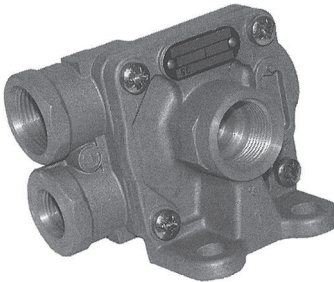

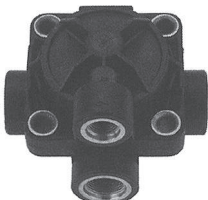
Schutzventil • Valve Protection • Válvula de Seguridad
Válvula de Proteção • Защитный клапан

Application	Description	Details	Ref.	Erqo No.
NG/MK/SK	<ul style="list-style-type: none"> EN Repair kit DE Reparatursatz FR Kit de réparation ES Kit de reparación PT Jogo reparo RU Ремонтный комплект 	repl. Knorr 1 487 010 234	000 430 2906	02.21348 
				
NG/MK/SK	<ul style="list-style-type: none"> EN Relay valve DE Relaisventil FR Valve relais ES Válvula de relé PT Válvula relé RU Ускорительный клапан 	repl. Knorr 0 481 026 021	002 429 9444	02.21330 
				
NG/MK/SK	<ul style="list-style-type: none"> EN Relay valve 1 x M 22 X 1,5 / 2 x M 16 X 1,5 DE Relaisventil 1 x M 22 x 1,5 / 2 x M 16 x 1,5 FR Valve relais 1 x M 22 x 1,5 / 2 x M1 6 x 1,5 ES Válvula de relé 1 x M 22 x 1,5 / 2 x M 16 x 1,5 PT Válvula relé 1 x M 22 x 1,5 / 2 x M 16 x 1,5 RU Ускорительный клапан 1 x M 22 x 1,5 / 2 x M 16 x 1,5 	repl. Wabco 973 001 020 0	001 429 9144	02.21322 
				
BM 650/651/652/653, 654/655/656/657, 658/659	<ul style="list-style-type: none"> EN Relay valve DE Relaisventil FR Valve relais ES Válvula de relé PT Válvula relé RU Ускорительный клапан 	repl. Wabco 973 500 028 0	004 429 2344	02.21338 
				
BM 625, 650/651/652/653, 654/655/656/657, 658/659	<ul style="list-style-type: none"> EN Relay valve DE Relaisventil FR Valve relais ES Válvula de relé PT Válvula relé RU Ускорительный клапан 	repl. Knorr 0 481 026 306	004 429 1144	02.21337 
				

THE ORIGINAL NUMBERS OF THE VEHICLE MANUFACTURER MAY BE USED FOR COMPARISON PURPOSES ONLY AND MUST NOT BE MENTIONED ON INVOICES TO VEHICLE OWNERS.

Protection Valve



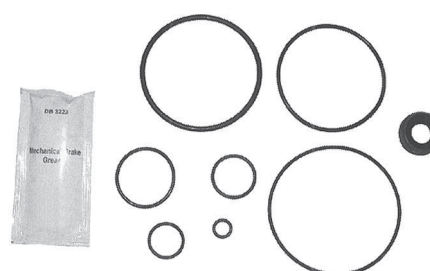
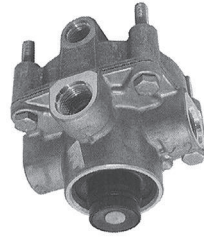

Schutzventil • Valve Protection • Válvula de Seguridad
 Válvula de Proteção • Защитный клапан

Application	Description	Details	Ref.	Erqo No.
BM 625, 653/654/655/656, 657/658/659	<ul style="list-style-type: none"> EN Relay valve DE Relaisventil FR Valve relais ES Válvula de relé PT Válvula relé RU Ускорительный клапан 	repl. Wabco 973 011 001 0	004 429 3844	02.21340 
NG/MK/SK	<ul style="list-style-type: none"> EN Repair kit DE Reparatursatz FR Kit de réparation ES Kit de reparación PT Jogo reparo RU Ремонтный комплект 	repl. Wabco 973 001 000 2	000 586 5742	02.22085 
NG/MK/SK	<ul style="list-style-type: none"> EN Repair kit DE Reparatursatz FR Kit de réparation ES Kit de reparación PT Jogo reparo RU Ремонтный комплект 	repl. Wabco 973 011 000 2	002 430 3060	02.21378 







Foot & Hand Brake Valve

Fuß- & Handbremsventil • Robinet de Frein à Pied & à Main • Válvulas del Freno de Servicio & Estacionamiento
Válvula de Freio de Pé & Mão • Тормозной клапан с двойным управлением









Application	Description	Details	Ref.	Erqo No.
BM 651/652/653/654, 655/656/657/658, 659	(EN) Foot brake valve (DE) Fußbremsventil (FR) Robinet de frein à pied (ES) Válvula del freno de servicio (PT) Válvula pedal freio (RU) Клапан тормозной системы	repl. Wabco 461 319 271 0	003 431 1705	02.21424 
BM 615/616/617/619, 620/621/622/623, 624/625, 645/646/648	(EN) Foot brake valve (DE) Fußbremsventil (FR) Robinet de frein à pied (ES) Válvula del freno de servicio (PT) Válvula pedal freio (RU) Двухконтурный тормозной клапан	repl. Wabco 461 319 008 0	002 431 0605	02.21415 
BM 615/616/617, 620/621/622/623, 624, 645/646/647/648	(EN) Foot brake valve (DE) Fußbremsventil (FR) Robinet de frein à pied (ES) Válvula del pedal de freno (PT) Válvula freio (RU) Тормозной клапан	repl. Wabco 461 315 008 0	001 431 8305	02.21408 
BM 625, 653/658	(EN) Foot brake valve (DE) Fußbremsventil (FR) Robinet de frein à pied (ES) Válvula del freno de servicio (PT) Válvula freio (RU) Тормозной клапан	repl. Wabco 461 319 280 0	003 431 1805	02.21425 

Foot & Hand Brake Valve

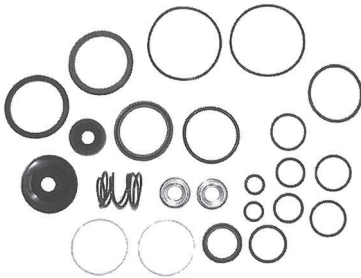

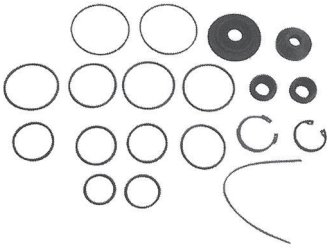

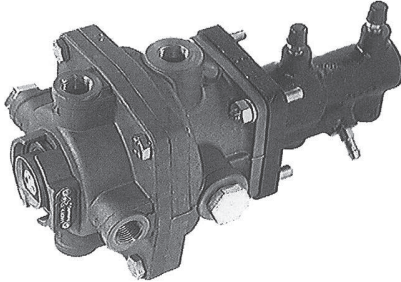

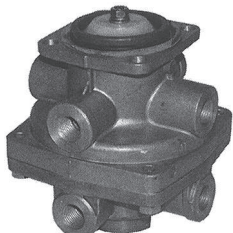

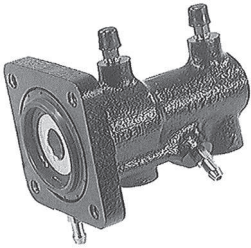

Fuß- & Handbremsventil • Robinet de Frein à Pied & à Main • Válvulas del Freno de Servicio & Estacionamiento
Válvula de Freio de Pé & Mão • Тормозной клапан с двойным управлением

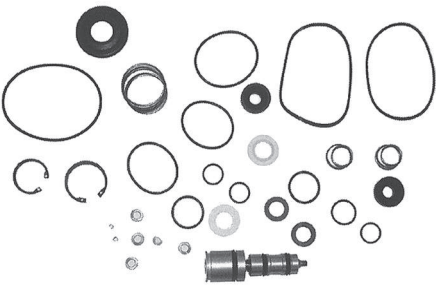
Application	Description	Details	Ref.	Erqo No.
BM 652/654/655/656, 657/658/659	<ul style="list-style-type: none"> EN Foot brake valve DE Fußbremsventil FR Robinet de frein à pied ES Válvula del freno de servicio PT Válvula pedal freio RU Клапан тормозной системы 	repl. Wabco 461 319 250 0	003 431 6305	02.21433 
MK/SK	<ul style="list-style-type: none"> EN Repair kit DE Reparatursatz FR Kit de réparation ES Kit de reparación PT Jogo reparo RU Ремонтный комплект 		000 430 3106	02.21350 
MK/SK	<ul style="list-style-type: none"> EN Repair kit DE Reparatursatz FR Kit de réparation ES Kit de reparación PT Jogo reparo RU Ремонтный комплект 		000 430 8506	02.21354 
MK/SK	<ul style="list-style-type: none"> EN Repair kit DE Reparatursatz FR Kit de réparation ES Kit de reparación PT Jogo reparo RU Ремонтный комплект 	repl. Wabco 461 319 001 2	000 430 6360	02.21369 
NG/MK/SK	<ul style="list-style-type: none"> EN Repair kit DE Reparatursatz FR Kit de réparation ES Kit de reparación PT Jogo reparo RU Ремонтный комплект 	repl. Wabco 461 315 007 2	000 430 1160	02.21365 

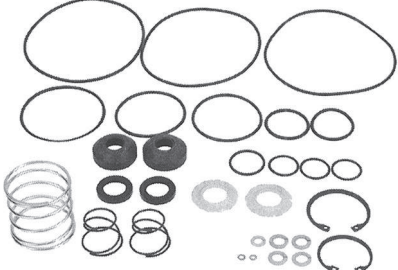
THE ORIGINAL NUMBERS OF THE VEHICLE MANUFACTURER MAY BE USED FOR COMPARISON PURPOSES ONLY AND MUST NOT BE MENTIONED ON INVOICES TO VEHICLE OWNERS.

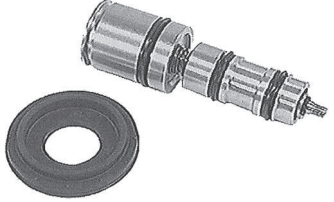
Application	Description	Details	Ref.	Erqo No.
NG/MK/SK	<ul style="list-style-type: none"> EN Repair kit DE Reparatursatz FR Kit de réparation ES Kit de reparación PT Jogo reparo RU Ремонтный комплект 	repl. Wabco 461 315 005 2	001 430 0460	02.21371 
				
NG/MK/SK	<ul style="list-style-type: none"> EN Repair kit DE Reparatursatz FR Kit de réparation ES Kit de reparación PT Jogo reparo RU Ремонтный комплект 	repl. 461 319 004 2	000 430 3006	02.21349 
				
NG/MK/SK	<ul style="list-style-type: none"> EN Repair kit DE Reparatursatz FR Kit de réparation ES Kit de reparación PT Jogo reparo RU Ремонтный комплект 	repl. Knorr 1 487 010 060	000 430 3506	02.21351 
				
BM 385/387/389, 391/393/395, 620/621/623/624	<ul style="list-style-type: none"> EN Brake valve DE Bremsventil FR Valve de frein ES Válvula de freno PT Válvula freio RU Тормозной клапан 	repl. Knorr 0 481 064 007	001 431 3505	02.21404 
				
BM 385/387/389, 391/393/395, 620/621/623/624	<ul style="list-style-type: none"> EN Brake valve DE Bremsventil FR Valve de frein ES Válvula de freno PT Válvula freio RU Тормозной клапан 	repl. Wabco 461 307 439 0	001 431 9305	02.21411 
				

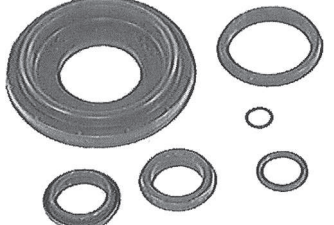



THE ORIGINAL NUMBERS OF THE VEHICLE MANUFACTURER MAY BE USED FOR COMPARISON PURPOSES ONLY AND MUST NOT BE MENTIONED ON INVOICES TO VEHICLE OWNERS.

Application	Description	Details	Ref.	Erqo No.
BM 385/387/389, 391/393/395, 620/621/623/624	<ul style="list-style-type: none"> EN Wheel cylinder DE Radzylinder FR Cylindre à roue ES Cilindro de rueda PT Cilindro freio roda RU Колесный тормозной цилиндр 		007 420 2118	02.21196 
BM 385/387/389, 391/393/395, 620/621/623/624	<ul style="list-style-type: none"> EN Repair kit DE Reparatursatz FR Kit de réparation ES Kit de reparación PT Jogo reparo RU Ремонтный комплект 			02.23228 
BM 385/387/389, 391/393/395, 620/621/623/624	<ul style="list-style-type: none"> EN Repair kit DE Reparatursatz FR Kit de réparation ES Kit de reparación PT Jogo reparo RU Ремонтный комплект 	repl. Wabco 461 307 002 2	000 586 8643	02.22097 
BM 385/387/389, 391/393/395, 620/621/623/624	<ul style="list-style-type: none"> EN Repair kit DE Reparatursatz FR Kit de réparation ES Kit de reparación PT Jogo reparo RU Ремонтный комплект 			02.23229 
BM 385/387/389, 391/393/395, 620/621/623/624	<ul style="list-style-type: none"> EN Repair kit DE Reparatursatz FR Kit de réparation ES Kit de reparación PT Jogo reparo RU Ремонтный комплект 			02.23229 
BM 385/387/389, 391/393/395, 620/621/623/624	<ul style="list-style-type: none"> EN Repair kit DE Reparatursatz FR Kit de réparation ES Kit de reparación PT Jogo reparo RU Ремонтный комплект 		002 586 5542	02.22091 





THE ORIGINAL NUMBERS OF THE VEHICLE MANUFACTURER MAY BE USED FOR COMPARISON PURPOSES ONLY AND MUST NOT BE MENTIONED ON INVOICES TO VEHICLE OWNERS.

Foot & Hand Brake Valve

Fuß- & Handbremsventil • Robinet de Frein à Pied & à Main • Válvulas del Freno de Servicio & Estacionamiento
Válvula de Freio de Pé & Mão • Тормозной клапан с двойным управлением

Application	Description	Details	Ref.	Erqo No.
BM 625, 650/651/652/653, 654/655/656/657, 658/659	EN Parking br.valve DE Feststellbremsventil FR Robinet de frein de parc ES Válvula del freno de estacionamiento PT Válvula estacionamento RU Кран	repl. Wabco 961 723 005 0	002 430 7881	02.21397 
BM 380/381/383/385, 387/389, 391/393/395, 620/621/622/623	EN Hand brake valve DE Handbremsventil FR Robinet de frein à main ES Válvula del freno de mano PT Válvula manetim RU Тормозной кран	repl. Wabco 961 701 105 0	000 430 5581	02.21384 
BM 615/616/617/619, 620/621/622/623, 624/625, 645/646/648	EN Hand brake valve DE Handbremsventil FR Robinet de frein à main ES Válvula del freno de mano PT Válvula manetim RU Тормозной кран	repl. Wabco 961 722 210 0	001 430 5681	02.21391 
NG	EN Hand brake valve DE Handbremsventil FR Robinet de frein à main ES Válvula del freno de mano PT Válvula manetim RU Тормозной кран	repl. Wabco 961 702 004 0	000 430 8581	02.21388 
NG	EN Hand brake valve DE Handbremsventil FR Robinet de frein à main ES Válvula del freno de mano PT Válvula manetim RU Тормозной кран	repl. Wabco 961 722 252 0	001 430 0981	02.21389 

THE ORIGINAL NUMBERS OF THE VEHICLE MANUFACTURER MAY BE USED FOR COMPARISON PURPOSES ONLY AND MUST NOT BE MENTIONED ON INVOICES TO VEHICLE OWNERS.

Application	Description	Details	Ref.	Erqo No.
BM 650/651/652/653, 654/655/656/657, 658/659	<ul style="list-style-type: none"> EN Hand brake valve DE Handbremsventil FR Robinet de frein à main ES Válvula del freno de mano PT Válvula manetim RU Тормозной кран 	repl. Wabco 961 723 104 0	002 430 7981	02.21398 
NG/MK/SK	<ul style="list-style-type: none"> EN Repair kit DE Reparatursatz FR Kit de réparation ES Kit de reparación PT Jogo reparo RU Ремонтный комплект 	repl. Wabco 961 723 000 2	003 430 5281	02.21402 
NG/MK/SK	<ul style="list-style-type: none"> EN Repair kit DE Reparatursatz FR Kit de réparation ES Kit de reparación PT Jogo reparo RU Ремонтный комплект 	repl. Wabco 961 722 002 2	003 430 3181	02.21400 
NG/MK/SK	<ul style="list-style-type: none"> EN Repair kit DE Reparatursatz FR Kit de réparation ES Kit de reparación PT Jogo reparo RU Ремонтный комплект 	repl. Wabco 961 701 000 2	000 430 5760	02.21367 
NG/MK/SK	<ul style="list-style-type: none"> EN Repair kit DE Reparatursatz FR Kit de réparation ES Kit de reparación PT Jogo reparo RU Ремонтный комплект 	repl Wabco 961 702 000 2	002 586 8843	02.22103 

THE ORIGINAL NUMBERS OF THE VEHICLE MANUFACTURER MAY BE USED FOR COMPARISON PURPOSES ONLY AND MUST NOT BE MENTIONED ON INVOICES TO VEHICLE OWNERS.

Foot & Hand Brake Valve





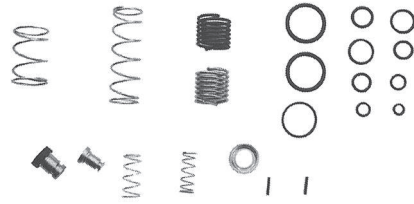



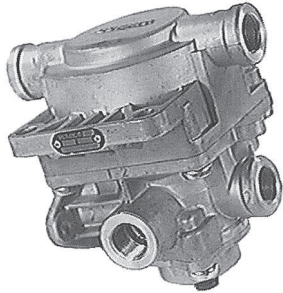

Fuß- & Handbremsventil • Robinet de Frein à Pied & à Main • Válvulas del Freno de Servicio & Estacionamiento
 Válvula de Freio de Pé & Mão • Тормозной клапан с двойным управлением

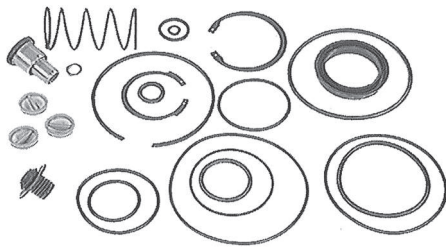
Application	Description	Details	Ref.	Erqo No.
NG/MK/SK	<ul style="list-style-type: none"> EN Repair kit DE Reparatursatz FR Kit de réparation ES Kit de reparación PT Jogo reparo RU Ремонтный комплект 	repl. Wabco 961 722 003 2	003 430 3281	02.21401

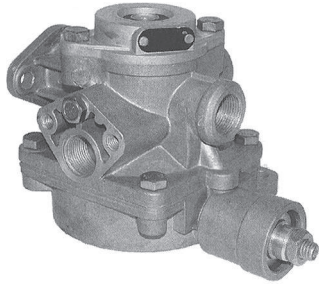

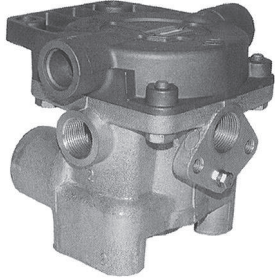
Trailer Brake Valve

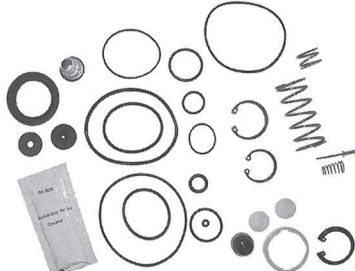





Anhängerbremventil • Robinet de Frein Remorque • Válvula de Freno de Remolque
 Válvula Freio Reboque • Тормозной клапан прицепа

Application	Description	Details	Ref.	Erqo No.
NG/MK/SK	<ul style="list-style-type: none"> EN Trailer brake valve DE Anhängerbremventil FR Valve de frein remorque ES Válvula de freno para remolque PT Válvula freio carreta reboque RU Тормозной клапан прицепа 	repl. Wabco 971 002 110 0		02.23232 
NG/MK/SK	<ul style="list-style-type: none"> EN Repair kit DE Reparatursatz FR Kit de réparation ES Kit de reparación PT Jogo reparo RU Ремонтный комплект 	repl. Wabco 971 002 001 2		02.23230 
NG/MK/SK	<ul style="list-style-type: none"> EN Trailer brake valve DE Anhängerbremventil FR Valve de frein remorque ES Válvula de freno para remolque PT Válvula freio carreta reboque RU Тормозной клапан прицепа 	repl. Wabco 971 002 150 0		02.23231 
NG/MK/SK	<ul style="list-style-type: none"> EN Trailer brake valve DE Anhängerbremventil FR Valve de frein remorque ES Válvula de freno para remolque PT Válvula freio carreta reboque RU Тормозной клапан прицепа 	repl. Wabco 971 002 152 0		02.23233 
NG/MK/SK	<ul style="list-style-type: none"> EN Repair kit DE Reparatursatz FR Kit de réparation ES Kit de reparación PT Jogo reparo RU Ремонтный комплект 	repl. Wabco 971 002 003 2		02.23234 

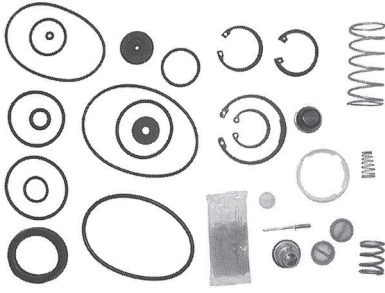
THE ORIGINAL NUMBERS OF THE VEHICLE MANUFACTURER MAY BE USED FOR COMPARISON PURPOSES ONLY AND MUST NOT BE MENTIONED ON INVOICES TO VEHICLE OWNERS.

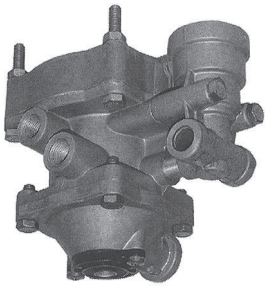
Trailer Brake Valve

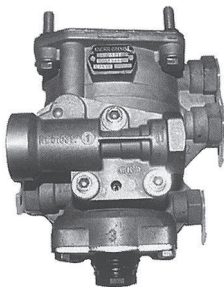

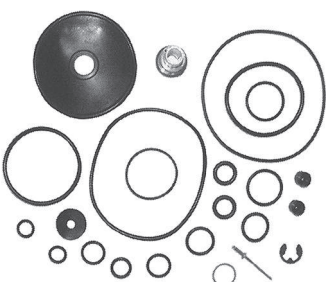
Anhängerbremssventil • Robinet de Frein Remorque • Válvula de Freno de Remolque
Válvula Freio Reboque • Тормозной клапан прицепа



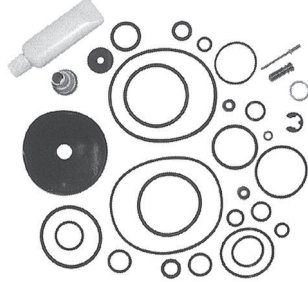

Application	Description	Details	Ref.	Erqo No.
SK	<ul style="list-style-type: none"> EN Repair kit DE Reparatursatz FR Kit de réparation ES Kit de reparación PT Jogo reparo RU Ремонтный комплект 	repl. Wabco 971 002 004 2		02.23235 
				
BM 385.052, 625.052/054/057, 625.374/382/392	<ul style="list-style-type: none"> EN Trailer control valve DE Anhängersteuerventil FR Valve, de controle de remorque ES Válvula de mando de remolque PT Válvula controle reboque RU Распределительный клапан 	repl. Wabco 973 002 520 0	001 431 6905	02.21406 
				
BM 650/651/652/653, 654/655/656/657, 658/659	<ul style="list-style-type: none"> EN Trailer control valve DE Anhängersteuerventil FR Valve de contrôle de remorque ES Válvula de mando de remolque PT Válvula controle reboque RU Распределительный клапан 	repl. Wabco 973 009 001 0	003 431 8205	02.21438 
				
SK	<ul style="list-style-type: none"> EN Repair kit DE Reparatursatz FR Kit de réparation ES Kit de reparación PT Jogo reparo RU Ремонтный комплект 	repl. Wabco 973 002 006 2	002 430 1860	02.21377 
				

THE ORIGINAL NUMBERS OF THE VEHICLE MANUFACTURER MAY BE USED FOR COMPARISON PURPOSES ONLY AND MUST NOT BE MENTIONED ON INVOICES TO VEHICLE OWNERS.

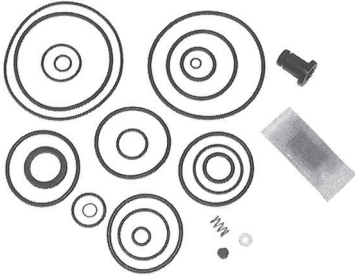

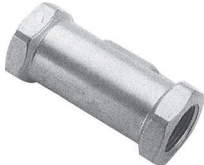
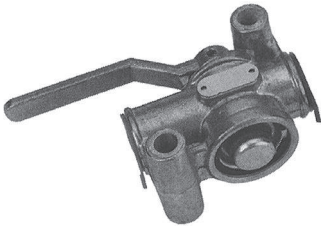
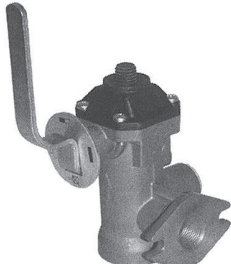

Trailer Brake Valve

Anhängerbremsventil • Robinet de Frein Remorque • Válvula de Freno de Remolque
 Válvula Freio Reboque • Тормозной клапан прицепа





Application	Description	Details	Ref.	Erqo No.
SK	<ul style="list-style-type: none"> EN Repair kit DE Reparatursatz FR Kit de réparation ES Kit de reparación PT Jogo reparo RU Ремонтный комплект 	repl. Wabco 973 002 005 2	002 430 1760	02.21376 
				
SK	<ul style="list-style-type: none"> EN Repair kit DE Reparatursatz FR Kit de réparation ES Kit de reparación PT Jogo reparo RU Ремонтный комплект 	repl. Wabco 973 009 000 2	000 430 3706	02.21352 
				





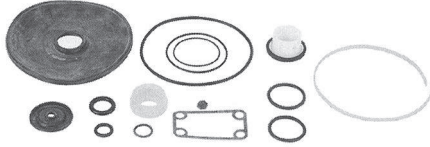

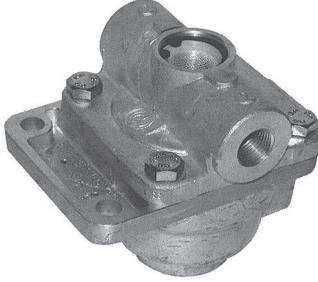
Application	Description	Details	Ref.	Erqo No.
BM 615/616/617/619, 620/621/622/623, 624/625, 645/646/648/649	<ul style="list-style-type: none"> EN Control valve DE Kontrollventil FR Soupape de contrôle ES Válvula de control PT Válvula controle RU Контрольный клапан 		002 429 9644	02.21331 
BM 625, 651/652/653/654, 655/656/657/658, 659	<ul style="list-style-type: none"> EN Relief valve DE Rückschlagventil FR Clapet anti retour ES Válvula de retención PT Válvula retenção RU Обратный клапан 		000 990 3472	02.22499 
BM 617/619, 625, 651/652/653/654, 655/656/657/658, 659	<ul style="list-style-type: none"> EN Relief valve DE Rückschlagventil FR Clapet anti retour ES Válvula de retención PT Válvula retenção RU Обратный клапан 	repl. Knorr AE5101 	003 429 0744	02.21332 
NG/MK/SK	<ul style="list-style-type: none"> EN Shut off cock DE Absperrhahn FR Vanne d'arrêt ES Llave de paso PT Torneira fechamento RU Запорный кран 	repl. Wabco 452 002 107 0 		02.23236 
NG/MK/SK	<ul style="list-style-type: none"> EN Empty-load valve DE Bremskraftregler FR Valve de frein ES Válvula reguladora de fuerza de frenado PT Válvula sensível carga RU Регулятор тормозных сил 	repl. Wabco 475 604 011 0 		02.23237 

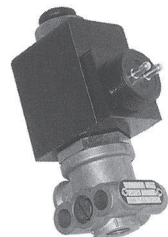
THE ORIGINAL NUMBERS OF THE VEHICLE MANUFACTURER MAY BE USED FOR COMPARISON PURPOSES ONLY AND MUST NOT BE MENTIONED ON INVOICES TO VEHICLE OWNERS.

Application	Description	Details	Ref.	Erqo No.
BM 387/389, 393, 620/621	<ul style="list-style-type: none"> EN Load sensitive valve DE Lastabhängiges Ventil FR Répartiteur de charge ES Válvula reguladora frenada dependiente de la carga PT Válvula sensível carga RU Регулятор тормозного нажатия 	repl. Wabco 475 700 122 0	001 431 5406	02.21449 
BM 621, 646	<ul style="list-style-type: none"> EN Load sensitive valve DE Lastabhängiges Ventil FR Répartiteur de charge ES Válvula reguladora frenada dependiente de la carga PT Válvula sensível carga RU Регулятор тормозного нажатия 		001 431 4212	02.21487 
BM 615/616/617/619, 620/621/622/623, 624/625, 645/646/648	<ul style="list-style-type: none"> EN Load sensitive valve DE Lastabhängiges Ventil FR Répartiteur de charge ES Válvula reguladora de carga PT Válvula sensível carga RU Клапан 	repl. Wabco 475 710 020 0	001 431 3312	02.21485 
MK/SK	<ul style="list-style-type: none"> EN Repair kit DE Reparatursatz FR Kit de réparation ES Kit de reparación PT Jogo reparo RU Ремонтный комплект 	repl. Wabco 475 711 000 2	000 430 3660	02.21366 
MK/SK	<ul style="list-style-type: none"> EN Repair kit DE Reparatursatz FR Kit de réparation ES Kit de reparación PT Jogo reparo RU Ремонтный комплект 	repl. Bosch 1 487 010 234	000 430 7560	02.21370 

THE ORIGINAL NUMBERS OF THE VEHICLE MANUFACTURER MAY BE USED FOR COMPARISON PURPOSES ONLY AND MUST NOT BE MENTIONED ON INVOICES TO VEHICLE OWNERS.

Application	Description	Details	Ref.	Erqo No.
MK/SK	<ul style="list-style-type: none"> EN Repair kit DE Reparatursatz FR Kit de réparation ES Kit de reparación PT Jogo reparo RU Ремонтный комплект 	repl. Knorr 1 487 010 098	000 430 1868	02.21383 
				
BM 385/387/389, 393/395, 619, 621/623/624	<ul style="list-style-type: none"> EN Reducing valve DE Reduzierventil FR Soupape de réduction ES Válvula reductora PT Válvula carga RU Редукционный клапан 	repl Wabco 473 300 014 0	000 431 3313	02.21489 
				
BM 625/645/646/647, 648/649/652/653, 654/655/656/657, 658/659	<ul style="list-style-type: none"> EN Valve, engine stop DE Ventil, Motorstop FR Soupape, Arrêt moteur ES Válvula, Parada del motor PT Válvula solenóide parada e freio motor RU Клапан, Остановка двигателя 		003 997 5336	02.22614 
				

Application	Description	Details	Ref.	Erqo No.
NG/MK/SK	<ul style="list-style-type: none"> EN Nylon pipe, transparent DE Polyamidrohr, transparent FR Tube nylon, transparent ES Tubo de tecalán, transparente PT Tubo nylon, transparente RU Полиамидная труба, прозрачная 	4 x 1 mm, in roll lengths of 25 m		02.23268 
			Sample	
NG/MK/SK	<ul style="list-style-type: none"> EN Nylon pipe, transparent DE Polyamidrohr, transparent FR Tube nylon, transparent ES Tubo de tecalán, transparente PT Tubo nylon, transparente RU Полиамидная труба, прозрачная 	6 x 1 mm, in roll lengths of 25 m		02.23269 
			Sample	
NG/MK/SK	<ul style="list-style-type: none"> EN Nylon pipe, transparent DE Polyamidrohr, transparent FR Tube nylon, transparent ES Tubo de tecalán, transparente PT Tubo nylon, transparente RU Полиамидная труба, прозрачная 	8 X 1 mm, in roll lengths of 25 m		02.23270 
			Sample	

Application	Description	Details	Ref.	Erqo No.
NG/MK/SK	<ul style="list-style-type: none"> EN Nylon pipe, transparent DE Polyamidrohr, transparent FR Tube nylon, transparent ES Tubo de tecalán, transparente PT Tubo nylon, transparente RU Полиамидная труба, прозрачная 	10 x 1 mm, in roll lengths of 25 m		02.23271



Sample







NG/MK/SK	<ul style="list-style-type: none"> EN Nylon pipe, black DE Polyamidrohr, schwarz FR Tube nylon, noir ES Tubo de tecalán, negro PT Tubo nylon, preto RU Полиамидная труба, черная 	4 x 1 mm, in roll lengths of 25 m		02.23272
----------	--	-----------------------------------	--	----------

















7

NG/MK/SK	<ul style="list-style-type: none"> EN Nylon pipe, black DE Polyamidrohr, schwarz FR Tube nylon, noir ES Tubo de tecalán, negro PT Tubo nylon, preto RU Полиамидная труба, черная 	6 x 1 mm, in roll lengths of 25 m		02.23273
----------	--	-----------------------------------	--	----------













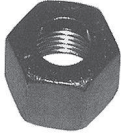





Application	Description	Details	Ref.	Erqo No.
NG/MK/SK	<ul style="list-style-type: none"> EN Nylon pipe, black DE Polyamidrohr, schwarz FR Tube nylon, noir ES Tubo de tecalán, negro PT Tubo nylon, preto RU Полиамидная труба, черная 	8 x 1 mm, in roll lengths of 25 m		02.23274 
NG/MK/SK	<ul style="list-style-type: none"> EN Nylon pipe, black DE Polyamidrohr, schwarz FR Tube nylon, noir ES Tubo de tecalán, negro PT Tubo nylon, preto RU Полиамидная труба, черная 	10 x 1 mm, in roll lengths of 25 m		02.23275 
NG/MK/SK	<ul style="list-style-type: none"> EN Nylon pipe, black DE Polyamidrohr, schwarz FR Tube nylon, noir ES Tubo de tecalán, negro PT Tubo nylon, preto RU Полиамидная труба, черная 	10 x 1,5 mm, in roll lengths of 25 m		02.23276 













Application	Description	Details	Ref.	Erqo No.
NG/MK/SK	<ul style="list-style-type: none"> EN Nylon pipe, black DE Polyamidrohr, schwarz FR Tube nylon, noir ES Tubo de tecalán, negro PT Tubo nylon, preto RU Полиамидная труба, черная 	11 x 1,5 mm, in roll lengths of 25 m		02.23277 
				
NG/MK/SK	<ul style="list-style-type: none"> EN Nylon pipe, black DE Polyamidrohr, schwarz FR Tube nylon, noir ES Tubo de tecalán, negro PT Tubo nylon, preto RU Полиамидная труба, черная 	12 x 1,5 mm, in roll lengths of 25 m		02.23278 
				
NG/MK/SK	<ul style="list-style-type: none"> EN Nylon pipe, black DE Polyamidrohr, schwarz FR Tube nylon, noir ES Tubo de tecalán, negro PT Tubo nylon, preto RU Полиамидная труба, черная 	15x1,5 mm, in roll lengths of 25 m		02.23279 
				









Application	Description	Details	Ref.	Erqo No.
NG/MK/SK	<ul style="list-style-type: none"> EN Nylon pipe, black DE Polyamidrohr, schwarz FR Tube nylon, noir ES Tubo de tecalán, negro PT Tubo nylon RU Полиамидная труба, черная 	16 x 2 mm, in roll lengths of 25 m		02.23280 
NG/MK/SK	<ul style="list-style-type: none"> EN Nylon pipe, black DE Polyamidrohr, schwarz FR Tube nylon, noir ES Tubo de tecalán, negro PT Tubo nylon, preto RU Полиамидная труба, черная 	18 x 2 mm, in roll lengths of 25 m		02.23281 
NG/MK/SK	<ul style="list-style-type: none"> EN Union nut DE Überwurfmutter FR Raccord union ES Tuerca de racor PT Porca união RU Накидная гайка 	4 mm, M 8 x 1		02.23282 
NG/MK/SK	<ul style="list-style-type: none"> EN Union nut DE Überwurfmutter FR Raccord union ES Tuerca de racor PT Porca união RU Накидная гайка 	6 mm, M 12 x 1,5		02.23283 
NG/MK/SK	<ul style="list-style-type: none"> EN Union nut DE Überwurfmutter FR Raccord union ES Tuerca de racor PT Porca união RU Накидная гайка 	8 mm, M 14 x 1,5		02.23284 







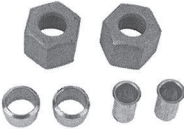



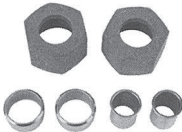

THE ORIGINAL NUMBERS OF THE VEHICLE MANUFACTURER MAY BE USED FOR COMPARISON PURPOSES ONLY AND MUST NOT BE MENTIONED ON INVOICES TO VEHICLE OWNERS.

Application	Description	Details	Ref.	Erqo No.
NG/MK/SK	<ul style="list-style-type: none"> EN Union nut DE Überwurfmutter FR Raccord union ES Tuerca de racor PT Porca união RU Накладная гайка 	10 mm, M 16 x 1,5		02.23285 
NG/MK/SK	<ul style="list-style-type: none"> EN Union nut DE Überwurfmutter FR Raccord union ES Tuerca de racor PT Porca união RU Накладная гайка 	12 mm, M 18 x 1,5		02.23286 
NG/MK/SK	<ul style="list-style-type: none"> EN Union nut DE Überwurfmutter FR Raccord union ES Tuerca de racor PT Porca união RU Накладная гайка 	15 mm, M 22 x 1,5		02.23287 
NG/MK/SK	<ul style="list-style-type: none"> EN Reinforcing sleeve DE Verstärkungshülse FR Douille de renforcement ES Casquillo de manguito PT Bucha reforçada RU Укрепляющая втулка 	4 x 1 mm		02.23288 
NG/MK/SK	<ul style="list-style-type: none"> EN Reinforcing sleeve DE Verstärkungshülse FR Douille de renforcement ES Casquillo de manguito PT Bucha reforçada RU Укрепляющая втулка 	6 x 1 mm		02.23289 
NG/MK/SK	<ul style="list-style-type: none"> EN Reinforcing sleeve DE Verstärkungshülse FR Douille de renforcement ES Casquillo de manguito PT Bucha reforçada RU Укрепляющая втулка 	8 x 1 mm		02.23290 













Application	Description	Details	Ref.	Erqo No.
NG/MK/SK	<ul style="list-style-type: none"> EN Reinforcing sleeve DE Verstärkungshülse FR Douille de renforcement ES Cásquillo de manguito PT Bucha reforçada RU Укрепляющая втулка 	10 x 1 mm		02.23291 
NG/MK/SK	<ul style="list-style-type: none"> EN Reinforcing sleeve DE Verstärkungshülse FR Douille de renforcement ES Cásquillo de manguito PT Bucha reforçada RU Укрепляющая втулка 	10 x 1,5 mm		02.23292 
NG/MK/SK	<ul style="list-style-type: none"> EN Reinforcing sleeve DE Verstärkungshülse FR Douille de renforcement ES Cásquillo de manguito PT Bucha reforçada RU Укрепляющая втулка 	12 x 1,5 mm		02.23293 
NG/MK/SK	<ul style="list-style-type: none"> EN Reinforcing sleeve DE Verstärkungshülse FR Douille de renforcement ES Cásquillo de manguito PT Bucha reforçada RU Укрепляющая втулка 	15 x 1,5 mm		02.23294 
NG/MK/SK	<ul style="list-style-type: none"> EN Reinforcing sleeve DE Verstärkungshülse FR Douille de renforcement ES Cásquillo de manguito PT Bucha reforçada RU Укрепляющая втулка 	18 x 2 mm		02.23295 
NG/MK/SK	<ul style="list-style-type: none"> EN Cutting ring DE Schneidring FR Olive ES Anillo cortante PT Anel RU Врезное кольцо 	4 mm		02.23296 

Application	Description	Details	Ref.	Erqo No.
NG/MK/SK	EN Cutting ring DE Schneidring FR Olive ES Anillo cortante PT Anel RU Врезное кольцо	6 mm		02.23297 
NG/MK/SK	EN Cutting ring DE Schneidring FR Olive ES Anillo cortante PT Anel RU Врезное кольцо	8 mm		02.23298 
NG/MK/SK	EN Cutting ring DE Schneidring FR Olive ES Anillo cortante PT Anel RU Врезное кольцо	10 mm		02.23299 
NG/MK/SK	EN Cutting ring DE Schneidring FR Olive ES Anillo cortante PT Anel RU Врезное кольцо	12 mm		02.23300 
NG/MK/SK	EN Cutting ring DE Schneidring FR Olive ES Anillo cortante PT Anel RU Врезное кольцо	15 mm		02.23301 
NG/MK/SK	EN Cutting ring DE Schneidring FR Olive ES Anillo cortante PT Anel RU Врезное кольцо	18 mm		02.23302 

Application	Description	Details	Ref.	Erqo No.
NG/MK/SK	<ul style="list-style-type: none"> EN Cutting ring DE Schneidring FR Olive ES Anillo cortante PT Anel RU Врезное кольцо 	22 mm		02.23303 
NG/MK/SK	<ul style="list-style-type: none"> EN Repair kit DE Reparatursatz FR Kit de réparation ES Kit de reparación PT Jogo reparo RU Ремонтный комплект 	for 4 x 1 mm tube		02.23304 
NG/MK/SK	<ul style="list-style-type: none"> EN Repair kit DE Reparatursatz FR Kit de réparation ES Kit de reparación PT Jogo reparo RU Ремонтный комплект 	for 6 x 1 mm tube		02.23305 
NG/MK/SK	<ul style="list-style-type: none"> EN Repair kit DE Reparatursatz FR Kit de réparation ES Kit de reparación PT Jogo reparo RU Ремонтный комплект 	for 8 x 1 mm tube		02.23306 
NG/MK/SK	<ul style="list-style-type: none"> EN Repair kit DE Reparatursatz FR Kit de réparation ES Kit de reparación PT Jogo reparo RU Ремонтный комплект 	for 10 x 1 mm tube		02.23307 
NG/MK/SK	<ul style="list-style-type: none"> EN Repair kit DE Reparatursatz FR Kit de réparation ES Kit de reparación PT Jogo reparo RU Ремонтный комплект 	for 12 x 1,5 mm tube		02.23308 

Application	Description	Details	Ref.	Erqo No.
NG/MK/SK	<ul style="list-style-type: none"> EN Repair kit DE Reparatursatz FR Kit de réparation ES Kit de reparación PT Jogo reparo RU Ремонтный комплект 	for 15 x 1,5 mm tube		02.23309
				
NG/MK/SK	<ul style="list-style-type: none"> EN Straight coupling DE Gerade Verschraubung FR Raccord union complet ES Unión roscada recta PT União roscado RU Прямое резьбовое соединение 	4 mm	002 990 8568	02.22491
				
NG/MK/SK	<ul style="list-style-type: none"> EN Straight coupling DE Gerade Verschraubung FR Raccord union complet ES Unión roscada recta PT União roscado RU Прямое резьбовое соединение 	6 mm		02.23310
				
NG/MK/SK	<ul style="list-style-type: none"> EN Straight coupling DE Gerade Verschraubung FR Raccord union complet ES Unión roscada recta PT União roscado RU Прямое резьбовое соединение 	8 mm		02.23311
				
NG/MK/SK	<ul style="list-style-type: none"> EN Straight coupling DE Gerade Verschraubung FR Raccord union complet ES Unión roscada recta PT União roscado RU Прямое резьбовое соединение 	10 mm		02.23312
				
NG/MK/SK	<ul style="list-style-type: none"> EN Straight coupling DE Gerade Verschraubung FR Raccord union complet ES Unión roscada recta PT União roscado RU Прямое резьбовое соединение 	12 mm		02.23313
				

THE ORIGINAL NUMBERS OF THE VEHICLE MANUFACTURER MAY BE USED FOR COMPARISON PURPOSES ONLY AND MUST NOT BE MENTIONED ON INVOICES TO VEHICLE OWNERS.

Application	Description	Details	Ref.	Erqo No.
NG/MK/SK	<ul style="list-style-type: none"> EN Straight coupling DE Gerade Verschraubung FR Raccord union complet ES Unión roscada recta PT União roscado RU Прямое резьбовое соединение 	15 mm		02.23314 
NG/MK/SK	<ul style="list-style-type: none"> EN Straight coupling DE Gerade Verschraubung FR Raccord union complet ES Unión roscada recta PT União roscado RU Прямое резьбовое соединение 	18 mm		02.23315 
NG/MK/SK	<ul style="list-style-type: none"> EN Repair kit DE Reparatursatz FR Kit de réparation ES Kit de reparación PT Jogo reparo RU Ремонтный комплект 	for 4 x 1 mm tube		02.23316 
NG/MK/SK	<ul style="list-style-type: none"> EN Repair kit DE Reparatursatz FR Kit de réparation ES Kit de reparación PT Jogo reparo RU Ремонтный комплект 	for 6 x 1 mm tube		02.23317 
NG/MK/SK	<ul style="list-style-type: none"> EN Repair kit DE Reparatursatz FR Kit de réparation ES Kit de reparación PT Jogo reparo RU Ремонтный комплект 	for 8 x 1 mm tube		02.23318 
NG/MK/SK	<ul style="list-style-type: none"> EN Repair kit DE Reparatursatz FR Kit de réparation ES Kit de reparación PT Jogo reparo RU Ремонтный комплект 	for 10 x 1 mm tube		02.23319 













Application	Description	Details	Ref.	Erqo No.
NG/MK/SK	<ul style="list-style-type: none"> EN Repair kit DE Reparatursatz FR Kit de réparation ES Kit de reparación PT Jogo reparo RU Ремонтный комплект 	for 12 x 1,5 mm tube		02.23320
				
NG/MK/SK	<ul style="list-style-type: none"> EN Repair kit DE Reparatursatz FR Kit de réparation ES Kit de reparación PT Jogo reparo RU Ремонтный комплект 	for 15 x 1,5 mm tube		02.23321
				
NG/MK/SK	<ul style="list-style-type: none"> EN Repair kit DE Reparatursatz FR Kit de réparation ES Kit de reparación PT Jogo reparo RU Ремонтный комплект 	for 8 x 1 mm tube	002 990 5971	02.22495
				
NG/MK/SK	<ul style="list-style-type: none"> EN Push-in-connector, brass DE Gerader Verbinder, Messing FR Connecteur, laiton ES Empalme recto, latón PT Engate rápido, latão RU Прямой соединительный элемент, латунь 	6 mm		02.23322
				
NG/MK/SK	<ul style="list-style-type: none"> EN Push-in-connector, brass DE Gerader Verbinder, Messing FR Connecteur, laiton ES Empalme recto, latón PT Engate rápido, latão RU Прямой соединительный элемент, латунь 	8 mm		02.23323
				
NG/MK/SK	<ul style="list-style-type: none"> EN Push-in-connector, brass DE Gerader Verbinder, Messing FR Connecteur, laiton ES Empalme recto, latón PT Engate rápido, latão RU Прямой соединительный элемент, латунь 	10 mm		02.23324
				







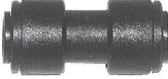



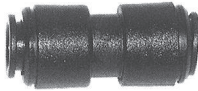

THE ORIGINAL NUMBERS OF THE VEHICLE MANUFACTURER MAY BE USED FOR COMPARISON PURPOSES ONLY AND MUST NOT BE MENTIONED ON INVOICES TO VEHICLE OWNERS.













Application	Description	Details	Ref.	Erqo No.
NG/MK/SK	<ul style="list-style-type: none"> EN Push-in-connector, brass DE Gerader Verbinder, Messing FR Connecteur, laiton ES Empalme recto, latón PT Engate rápido, latão RU Прямой соединительный элемент, латунь 	12 mm		02.23325 
NG/MK/SK	<ul style="list-style-type: none"> EN Push-in-connector, brass DE Gerader Verbinder, Messing FR Connecteur, laiton ES Empalme recto, latón PT Engate rápido, latão RU Прямой соединительный элемент, латунь 	15 mm		02.23326 
NG/MK/SK	<ul style="list-style-type: none"> EN T-connector, brass DE T-Verbinder, Messing FR Raccord en T, laiton ES Empalme T, latón PT Conector-T, latão RU T-образный соединительный элемент, латунь 	6 mm		02.23327 
NG/MK/SK	<ul style="list-style-type: none"> EN T-connector, brass DE T-Verbinder, Messing FR Raccord en T, laiton ES Empalme T, latón PT Conector-T, latão RU T-образный соединительный элемент, латунь 	8 mm		02.23328 
NG/MK/SK	<ul style="list-style-type: none"> EN T-connector, brass DE T-Verbinder, Messing FR Raccord en T, laiton ES Empalme T, latón PT Conector-T, latão RU T-образный соединительный элемент, латунь 	10 mm		02.23329 

Application	Description	Details	Ref.	Erqo No.
NG/MK/SK	<ul style="list-style-type: none"> EN T-connector, brass DE T-Verbinder, Messing FR Raccord en T, laiton ES Empalme T, latón PT Conector-T, latão RU Т-образный соединительный элемент, латунь 	12 mm		02.23330 
NG/MK/SK	<ul style="list-style-type: none"> EN T-connector, brass DE T-Verbinder, Messing FR Raccord en T, laiton ES Empalme T, latón PT Conector-T, latão RU Т-образный соединительный элемент, латунь 	15 mm		02.23331 
NG/MK/SK	<ul style="list-style-type: none"> EN Elbow connector, brass DE Winkel Verbinder, Messing FR Raccord coudé, laiton ES Empalme acodado, latón PT Cotovelo, latão RU Угловой соединительный элемент, латунь 	6 mm		02.23332 
NG/MK/SK	<ul style="list-style-type: none"> EN Elbow connector, brass DE Winkel Verbinder, Messing FR Raccord coudé, laiton ES Empalme acodado, latón PT Cotovelo, latão RU Угловой соединительный элемент, латунь 	8 mm		02.23333 
NG/MK/SK	<ul style="list-style-type: none"> EN Elbow connector, brass DE Winkel Verbinder, Messing FR Raccord coudé, laiton ES Empalme acodado, latón PT Cotovelo, latão RU Угловой соединительный элемент, латунь 	10 mm		02.23334 













THE ORIGINAL NUMBERS OF THE VEHICLE MANUFACTURER MAY BE USED FOR COMPARISON PURPOSES ONLY AND MUST NOT BE MENTIONED ON INVOICES TO VEHICLE OWNERS.

Application	Description	Details	Ref.	Erqo No.
NG/MK/SK	<ul style="list-style-type: none"> EN Elbow connector, brass DE Winkel Verbinder, Messing FR Raccord coudé, laiton ES Empalme acodado, latón PT Cotovelo, latão RU Угловой соединительный элемент, латунь 	12 mm		02.23335 
NG/MK/SK	<ul style="list-style-type: none"> EN Elbow connector, brass DE Winkel Verbinder, Messing FR Raccord coudé, laiton ES Empalme acodado, latón PT Cotovelo, latão RU Угловой соединительный элемент, латунь 	15 mm		02.23336 
NG/MK/SK	<ul style="list-style-type: none"> EN Push-In-connector, plastic DE Gerader Verbinder, Kunststoff FR Connecteur, plastique ES Empalme recto, plástico PT Conexão reta, plástico RU Прямой соединительный элемент, пластик 	4 mm		02.23337 
NG/MK/SK	<ul style="list-style-type: none"> EN Push-in-connector, plastic DE Gerader Verbinder, Kunststoff FR Connecteur, plastique ES Empalme recto, plástico PT Conexão reta, plástico RU Прямой соединительный элемент, пластик 	5 mm		02.23338 
NG/MK/SK	<ul style="list-style-type: none"> EN Push-in-connector, plastic DE Gerader Verbinder, Kunststoff FR Connecteur, plastique ES Empalme recto, plástico PT Conexão reta, plástico RU Прямой соединительный элемент, пластик 	6 mm		02.23339 
NG/MK/SK	<ul style="list-style-type: none"> EN Push-in-connector, plastic DE Gerader Verbinder, Kunststoff FR Connecteur, plastique ES Empalme recto, plástico PT Conexão reta, plástico RU Прямой соединительный элемент, пластик 	8 mm		02.23340 

Application	Description	Details	Ref.	Erqo No.
NG/MK/SK	<ul style="list-style-type: none"> EN Push-in-connector, plastic DE Gerader Verbinder, Kunststoff FR Connecteur, plastique ES Empalme recto, plástico PT Conexão reta, plástico RU Прямой соединительный элемент, пластик 	10 mm		02.23341 
NG/MK/SK	<ul style="list-style-type: none"> EN Push-in-connector, plastic DE Gerader Verbinder, Kunststoff FR Connecteur, plastique ES Empalme recto, plástico PT Conexão reta, plástico RU Прямой соединительный элемент, пластик 	12 mm		02.23342 
NG/MK/SK	<ul style="list-style-type: none"> EN Push-in-connector, plastic DE Gerader Verbinder, Kunststoff FR Connecteur, plastique ES Empalme recto, plástico PT Conexão reta, plástico RU Прямой соединительный элемент, пластик 	15 mm		02.23343 
NG/MK/SK	<ul style="list-style-type: none"> EN Push-in-connector, plastic DE Gerader Verbinder, Kunststoff FR Connecteur, plastique ES Empalme recto, plástico PT Conexão reta, plástico RU Прямой соединительный элемент, пластик 	18 mm		02.23344 
NG/MK/SK	<ul style="list-style-type: none"> EN Push-in-connector, plastic DE Gerader Verbinder, Kunststoff FR Connecteur, plastique ES Empalme recto, plástico PT Conexão reta, plástico RU Прямой соединительный элемент, пластик 	22 mm		02.23345 
NG/MK/SK	<ul style="list-style-type: none"> EN Elbow connector, plastic DE Winkelverbinder, Kunststoff FR Raccord coudé, plastique ES Empalme acodado, plástico PT Cotovelo, plástico RU Угловой соединительный элемент, пластик 	4 mm		02.23346 

Application	Description	Details	Ref.	Erqo No.
NG/MK/SK	<ul style="list-style-type: none"> EN Elbow connector, plastic DE Winkelverbinder, Kunststoff FR Raccord coudé, plastique ES Empalme acodado, plástico PT Cotovelo, plástico RU Угловой соединительный элемент, пластик 	5 mm		02.23347 
NG/MK/SK	<ul style="list-style-type: none"> EN Elbow connector, plastic DE Winkelverbinder, Kunststoff FR Raccord coudé, plastique ES Empalme acodado, plástico PT Cotovelo, plástico RU Угловой соединительный элемент, пластик 	6 mm		02.23348 
NG/MK/SK	<ul style="list-style-type: none"> EN Elbow connector, plastic DE Winkelverbinder, Kunststoff FR Raccord coudé, plastique ES Empalme acodado, plástico PT Cotovelo, plástico RU Угловой соединительный элемент, пластик 	8 mm		02.23349 
NG/MK/SK	<ul style="list-style-type: none"> EN Elbow connector, plastic DE Winkelverbinder, Kunststoff FR Raccord coudé, plastique ES Empalme acodado, plástico PT Cotovelo, plástico RU Угловой соединительный элемент, пластик 	10 mm		02.23350 
NG/MK/SK	<ul style="list-style-type: none"> EN Elbow connector, plastic DE Winkelverbinder, Kunststoff FR Raccord coudé, plastique ES Empalme acodado, plástico PT Cotovelo, plástico RU Угловой соединительный элемент, пластик 	12 mm		02.23351 
NG/MK/SK	<ul style="list-style-type: none"> EN Elbow connector, plastic DE Winkelverbinder, Kunststoff FR Raccord coudé, plastique ES Empalme acodado, plástico PT Cotovelo, plástico RU Угловой соединительный элемент, пластик 	15 mm		02.23352 

THE ORIGINAL NUMBERS OF THE VEHICLE MANUFACTURER MAY BE USED FOR COMPARISON PURPOSES ONLY AND MUST NOT BE MENTIONED ON INVOICES TO VEHICLE OWNERS.

Application	Description	Details	Ref.	Erqo No.
NG/MK/SK	<ul style="list-style-type: none"> EN Elbow connector, plastic DE Winkelverbinder, Kunststoff FR Raccord coudé, plastique ES Empalme acodado, plástico PT Cotovelo, plástico RU Угловой соединительный элемент, пластик 	18 mm		02.23353 
NG/MK/SK	<ul style="list-style-type: none"> EN Elbow connector, plastic DE Winkelverbinder, Kunststoff FR Raccord coudé, plastique ES Empalme acodado, plástico PT Cotovelo, plástico RU Угловой соединительный элемент, пластик 	22 mm		02.23354 
NG/MK/SK	<ul style="list-style-type: none"> EN T-connector, plastic DE T-Verbinder, Kunststoff FR Raccord en T, plastique ES Empalme T, plástico PT Conector-T, plástico RU Т-образный соединительный элемент, пластик 	4 mm		02.23355 
NG/MK/SK	<ul style="list-style-type: none"> EN T-connector, plastic DE T-Verbinder, Kunststoff FR Raccord en T, plastique ES Empalme T, plástico PT Conector-T, plástico RU Т-образный соединительный элемент, пластик 	5 mm		02.23356 
NG/MK/SK	<ul style="list-style-type: none"> EN T-connector, plastic DE T-Verbinder, Kunststoff FR Raccord en T, plastique ES Empalme T, plástico PT Conector-T, plástico RU Т-образный соединительный элемент, пластик 	6 mm		02.23357 
NG/MK/SK	<ul style="list-style-type: none"> EN T-connector, plastic DE T-Verbinder, Kunststoff FR Raccord en T, plastique ES Empalme T, plástico PT Conector-T, plástico RU Т-образный соединительный элемент, пластик 	8 mm		02.23358 

THE ORIGINAL NUMBERS OF THE VEHICLE MANUFACTURER MAY BE USED FOR COMPARISON PURPOSES ONLY AND MUST NOT BE MENTIONED ON INVOICES TO VEHICLE OWNERS.

Application	Description	Details	Ref.	Erqo No.
NG/MK/SK	<ul style="list-style-type: none"> EN T-connector, plastic DE T-Verbinder, Kunststoff FR Raccord en T, plastique ES Empalme T, plástico PT Conector-T, plástico RU T-образный соединительный элемент, пластик 	10 mm		02.23359 
NG/MK/SK	<ul style="list-style-type: none"> EN T-connector, plastic DE T-Verbinder, Kunststoff FR Raccord en T, plastique ES Empalme T, plástico PT Conector-T, plástico RU T-образный соединительный элемент, пластик 	18 mm		02.23360 
NG/MK/SK	<ul style="list-style-type: none"> EN T-connector, plastic DE T-Verbinder, Kunststoff FR Raccord en T, plastique ES Empalme T, plástico PT Conector-T, plástico RU T-образный соединительный элемент, пластик 	22 mm		02.23361 
NG/MK/SK	<ul style="list-style-type: none"> EN Thrust ring DE Druckring FR Anneau de serrage ES Anillo de presión PT Anel pressão cano ar RU Упорное кольцо 	Ø 18 mm		02.23362 
NG/MK/SK	<ul style="list-style-type: none"> EN Thrust ring DE Druckring FR Fret de joint speed ES Anillo de presión PT Anel pressão RU Упорное кольцо 	Ø 15 mm		02.23363 
NG/MK/SK	<ul style="list-style-type: none"> EN Elbow fitting DE Winkelstück FR Raccord coudé ES Pieza acodada PT Cotovelo RU Колено 	M 16 x 1,5 / Ø 8 mm		02.23364 

Application	Description	Details	Ref.	Erqo No.
NG/MK/SK	<ul style="list-style-type: none"> EN Banjo fitting DE Ringschlauchnippel FR Raccord banjo ES Racor de anillo para tubo flexible PT Terminal RU Патрубок шланга 	Ø 8 mm / Ø 4 mm	915052 004004	02.22993 
				
NG/MK/SK	<ul style="list-style-type: none"> EN Banjo fitting DE Ringschlauchnippel FR Raccord banjo ES Racor de anillo para tubo flexible PT Terminal RU Патрубок шланга 	Ø 10 mm / Ø 4 mm	915052 004003	02.22992 
				
NG/MK/SK	<ul style="list-style-type: none"> EN Banjo fitting DE Ringschlauchnippel FR Raccord banjo ES Racor de anillo para tubo flexible PT Terminal RU Патрубок шланга 	Ø 12 mm / Ø 4 mm	915052 004006	02.22994 
				
NG/MK/SK	<ul style="list-style-type: none"> EN Banjo fitting DE Ringschlauchnippel FR Raccord banjo ES Racor de anillo para tubo flexible PT Terminal RU Патрубок шланга 	Ø 14 mm / Ø 4 mm	915052 004007	02.22995 
				
NG/MK/SK	<ul style="list-style-type: none"> EN Banjo fitting DE Ringschlauchnippel FR Raccord banjo ES Racor de anillo para tubo flexible PT Terminal RU Патрубок шланга 	Ø 16 mm / Ø 4 mm	915052 004002	02.23365 
				
NG/MK/SK	<ul style="list-style-type: none"> EN Banjo fitting DE Ringschlauchnippel FR Raccord banjo ES Racor de anillo para tubo flexible PT Terminal RU Патрубок шланга 	Ø 12 mm / Ø 5 mm	000 990 8988	02.22512 
				

THE ORIGINAL NUMBERS OF THE VEHICLE MANUFACTURER MAY BE USED FOR COMPARISON PURPOSES ONLY AND MUST NOT BE MENTIONED ON INVOICES TO VEHICLE OWNERS.

Application	Description	Details	Ref.	Erqo No.
NG/MK/SK	EN Banjo fitting DE Ringschlauchnippel FR Raccord banjo ES Racor de anillo para tubo flexible PT Terminal RU Патрубок шланга	Ø 10 mm / Ø 6 mm	915052 006003	02.23001 
				
NG/MK/SK	EN Banjo fitting DE Ringschlauchnippel FR Raccord banjo ES Racor de anillo para tubo flexible PT Terminal RU Патрубок шланга	Ø 12 mm / Ø 6 mm	915052 006013	02.23003 
				
NG/MK/SK	EN Banjo fitting DE Ringschlauchnippel FR Raccord banjo ES Racor de anillo para tubo flexible PT Terminal RU Патрубок шланга	Ø 14 mm / Ø 6 mm	915052 006005	02.23002 
				
NG/MK/SK	EN Banjo fitting DE Ringschlauchnippel FR Raccord banjo ES Racor de anillo para tubo flexible PT Terminal RU Патрубок шланга	Ø 16 mm / Ø 6 mm	915052 006002	02.23000 
				
NG/MK/SK	EN Banjo fitting DE Ringschlauchnippel FR Raccord banjo ES Racor de anillo para tubo flexible PT Terminal RU Патрубок шланга	Ø 12 mm / Ø 8 mm	915052 008000	02.23366 
				
NG/MK/SK	EN Banjo fitting DE Ringschlauchnippel FR Raccord banjo ES Racor de anillo para tubo flexible PT Terminal RU Патрубок шланга	Ø 14 mm / Ø 8 mm	915052 008000	02.23004 
				

THE ORIGINAL NUMBERS OF THE VEHICLE MANUFACTURER MAY BE USED FOR COMPARISON PURPOSES ONLY AND MUST NOT BE MENTIONED ON INVOICES TO VEHICLE OWNERS.

Application	Description	Details	Ref.	Erqo No.
NG/MK/SK	<ul style="list-style-type: none"> EN Banjo fitting DE Ringschlauchnippel FR Raccord banjo ES Racor de anillo para tubo flexible PT Terminal RU Патрубок шланга 	Ø 16 mm / Ø 8 mm	915052 008001	02.23367 
				
NG/MK/SK	<ul style="list-style-type: none"> EN Banjo fitting DE Ringschlauchnippel FR Raccord banjo ES Racor de anillo para tubo flexible PT Terminal RU Патрубок шланга 	Ø 14 mm / Ø 9 / 10"		02.23368 
				
NG/MK/SK	<ul style="list-style-type: none"> EN Banjo fitting DE Ringschlauchnippel FR Raccord banjo ES Racor de anillo para tubo flexible PT Terminal RU Патрубок шланга 	Ø 16 mm / Ø 9 / 10"	915052 009000	02.23006 
				
NG/MK/SK	<ul style="list-style-type: none"> EN Hollow screw fitting DE Hohlschraubstutzen FR Raccord banjo ES Racor para perno hueco PT Parafuso vazado RU Пустотелая горловина 	M 16 x 1,5 / M 12 x 1,5	915039 012200	02.23369 
				
NG/MK/SK	<ul style="list-style-type: none"> EN Hollow screw fitting DE Hohlschraubstutzen FR Raccord banjo ES Racor para perno hueco PT Parafuso vazado RU Пустотелая горловина 	M 16 x 1,5 / M 12 x 1,5	915040 012200	02.23370 
				
NG/MK/SK	<ul style="list-style-type: none"> EN Hollow screw DE Hohlschraube FR Vis banjo ES Perno hueco PT Parafuso vazado RU Пустотельный болт 	M 8 x 1	915036 005100	02.22974 
				

Application	Description	Details	Ref.	Erqo No.
NG/MK/SK	<ul style="list-style-type: none"> EN Hollow screw DE Hohlschraube FR Vis banjo ES Perno hueco PT Parafuso vazado RU Пустотельный болт 	M 10 x 1	915011 004103	02.22967 
				
NG/MK/SK	<ul style="list-style-type: none"> EN Hollow screw DE Hohlschraube FR Vis banjo ES Perno hueco PT Parafuso vazado RU Пустотельный болт 	M 12 x 1,5	915011 006104	02.22968 
				
NG/MK/SK	<ul style="list-style-type: none"> EN Hollow screw DE Hohlschraube FR Vis banjo ES Perno hueco PT Parafuso vazado RU Пустотельный болт 	M 14 x 1,5		02.23371 
				
NG/MK/SK	<ul style="list-style-type: none"> EN Hollow screw DE Hohlschraube FR Vis banjo ES Perno hueco PT Parafuso vazado RU Пустотельный болт 	M 16 x 1,5	915036 012101	02.22981 
				
NG/MK/SK	<ul style="list-style-type: none"> EN Hollow screw DE Hohlschraube FR Vis banjo ES Perno hueco PT Parafuso vazado RU Пустотельный болт 	M 18 x 1,5	915011 013102	02.23372 
				
NG/MK/SK	<ul style="list-style-type: none"> EN Double hollow screw DE Doppelhohlschraube FR Vis banjo double ES Perno hueco doble PT Parafuso duplo, vazado RU Двойной пустотельный болт 	M 8 x 1	326 070 0063	02.19829 
				

Application	Description	Details	Ref.	Erqo No.
NG/MK/SK	<ul style="list-style-type: none"> EN Double hollow screw DE Doppelhohlschraube FR Vis banjo double ES Perno hueco doble PT Parafuso duplo, vazado RU Двойной пустотельный болт 	M 10 x 1	915047 006100	02.23373 
				
NG/MK/SK	<ul style="list-style-type: none"> EN Double hollow screw DE Doppelhohlschraube FR Vis banjo double ES Perno hueco doble PT Parafuso duplo, vazado RU Двойной пустотельный болт 	M 12 x 1,5	915047 008100	02.22985 
				
NG/MK/SK	<ul style="list-style-type: none"> EN Double hollow screw DE Doppelhohlschraube FR Vis banjo double ES Perno hueco doble PT Parafuso duplo, vazado RU Двойной пустотельный болт 	M 14 x 1,5	915047 010100	02.22987 
				
NG/MK/SK	<ul style="list-style-type: none"> EN Double hollow screw DE Doppelhohlschraube FR Vis banjo double ES Perno hueco doble PT Parafuso duplo RU Двойной пустотельный болт 	M 16 x 1,5	915047 012100	02.22989 
				
NG/MK/SK	<ul style="list-style-type: none"> EN Test coupling DE Prüfanschluss FR Raccord de contrôle ES Conexión de comprobación PT Conexão ensaio RU Контрольный выход 		000 431 2031	02.21503 
				
NG/MK/SK	<ul style="list-style-type: none"> EN Drain valve DE Entwässerungsventil FR Valve purge de bouteille air ES Válvula de purga de agua PT Válvula dreño RU Водоспускной клапан 			02.23374 
				

THE ORIGINAL NUMBERS OF THE VEHICLE MANUFACTURER MAY BE USED FOR COMPARISON PURPOSES ONLY AND MUST NOT BE MENTIONED ON INVOICES TO VEHICLE OWNERS.

Application	Description	Details	Ref.	Erqo No.
NG/MK/SK	<ul style="list-style-type: none"> EN Transfer pipe DE Übergangstutzen FR Raccord ES Racor adaptador PT Conexão RU Переходный штуцер 	M 16 x 1,5		02.23375
				
NG/MK/SK	<ul style="list-style-type: none"> EN Stud coupling DE Stutzen FR Raccord ES Racor PT Conexão RU Патрубок 	M 16 x 1,5 / M 18 x 1,5	074313 012304	02.22927
				
NG/MK/SK	<ul style="list-style-type: none"> EN Reducing adaptor DE Reduzier-Adapter FR Adaptateur de réduction ES Adaptador reductor PT Adaptador redutor RU Переходной адаптер 	M 22 x 1,5 / M 12 x 1,5		02.23376
				
NG/MK/SK	<ul style="list-style-type: none"> EN Reducing adaptor DE Reduzier-Adapter FR Adaptateur de réduction ES Adaptador reductor PT Adaptador redutor RU Переходной адаптер 	M 22 x 1,5 / M 14 x 1,5		02.23377
				
NG/MK/SK	<ul style="list-style-type: none"> EN Reducing adaptor DE Reduzier-Adapter FR Adaptateur de réduction ES Adaptador reductor PT Adaptador redutor RU Переходной адаптер 	M 22 x 1,5 / M 16 x 1,5	000 990 5168	02.23378
				
NG/MK/SK	<ul style="list-style-type: none"> EN Hose nozzle DE Schlauchnippel FR Filière de tube ES Boquilla de manguera PT Conexão reta manguêira RU патрубок шланга 	11 x 4 mm	074 304 16200	02.23379
				

Application	Description	Details	Ref.	Erqo No.
NG/MK/SK	<ul style="list-style-type: none"> EN Hose nipple DE Schlauchnippel FR Filière de tube ES Boquilla de manguera PT Conector mangueira RU Патрубок шланга 	13 x 6 mm		02.23380



NG/MK/SK	<ul style="list-style-type: none"> EN Brake hose DE Bremsschlauch FR Durite de frein ES Tubo flexible de freno PT Mangueira RU Тормозной шланг 	11 x 4 mm, in roll lengths of 50 m	916027 011014	02.23015
----------	--	------------------------------------	---------------	----------



Sample





NG/MK/SK	<ul style="list-style-type: none"> EN Brake hose DE Bremsschlauch FR Durite de frein ES Tubo flexible de freno PT Mangueira RU Тормозной шланг 	13 x 6 mm, in roll lengths of 50 m	916027 013006	02.23016
----------	--	------------------------------------	---------------	----------

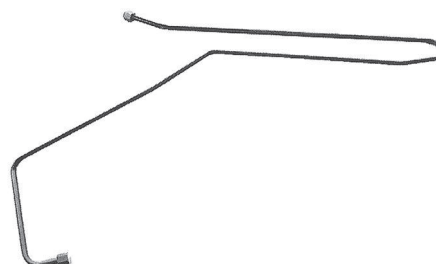



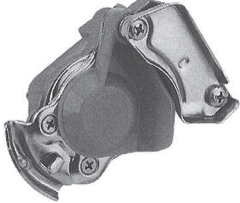



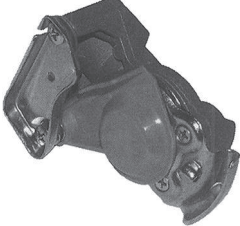

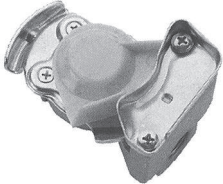

NG/MK/SK	<ul style="list-style-type: none"> EN Brake line, no. 5 DE Bremsrohr, Nr. 5 FR Flexible de frein, n° 5 ES Tubo de freno, n° 5 PT Tubo de freio, n° 5 RU Трубопровод, no. 5 	Ø 15 mm, 2566 mm, M 22 x 1,5		02.23381
----------	--	------------------------------	--	----------





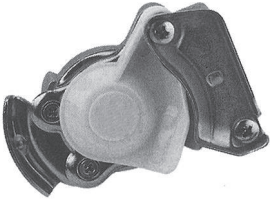





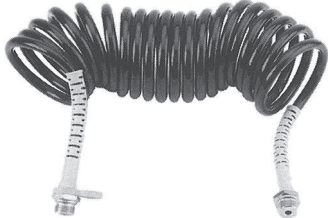

THE ORIGINAL NUMBERS OF THE VEHICLE MANUFACTURER MAY BE USED FOR COMPARISON PURPOSES ONLY AND MUST NOT BE MENTIONED ON INVOICES TO VEHICLE OWNERS.











Application	Description	Details	Ref.	Erqo No.
NG/MK/SK	<p>EN Palm coupling, red lid with double connection</p> <p>DE Kupplungskopf, roter Deckel mit Doppelanschluss</p> <p>FR Main d'accouplement, couvercle rouge avec double connexion</p> <p>ES Cabeza de acoplamiento, Tapa roja con doble conector</p> <p>PT Mão-de-amigo, vermelho com conexão dupla</p> <p>RU Соединительная головка, красная крышка с двойным подключением</p>	M 16 x 1,5, repl. Wabco: 952 200 210 0	000 429 7830	<p>02.21305</p> 
				
NG/MK/SK	<p>EN Palm coupling, yellow lid alu, error safe</p> <p>DE Kupplungskopf, gelber Deckel Alu, vertauschgesichert</p> <p>FR Main d'accouplement, couvercle jaune alu, sans risque</p> <p>ES Cabeza de acoplamiento, Tapa amarilla aluminio, protegido contra error</p> <p>PT Mão-de-amigo, amarelo aluminio, com dispositivo de segurança</p> <p>RU Соединительная головка, желтая крышка Алюминиевая, защищенная от случайного срабатывания</p>	M 22 x 1,5, repl. Wabco: 452 200 012 0	000 429 3330	<p>02.21286</p> 
				
NG/MK/SK	<p>EN Palm coupling, red lid alu, error safe</p> <p>DE Kupplungskopf, roter Deckel Alu, vertauschgesichert</p> <p>FR Main d'accouplement, couvercle rouge alu, sans risque</p> <p>ES Cabeza de acoplamiento, Tapa roja aluminio, protegido contra error</p> <p>PT Mão-de-amigo, vermelho aluminio, com dispositivo de segurança</p> <p>RU Соединительная головка, красная крышка Алюминиевая, защищенная от случайного срабатывания</p>	M 22 x 1,5, repl. Wabco: 452 200 011 0	000 429 3430	<p>02.21287</p> 
				

Application	Description	Details	Ref.	Erqo No.
NG/MK/SK	<p>EN Palm coupling, yellow lid alu, error safe</p> <p>DE Kupplungskopf, gelber Deckel Alu, vertauschgesichert</p> <p>FR Main d'accouplement, couvercle jaune alu, sans risque</p> <p>ES Cabeza de acoplamiento, Tapa amarilla aluminio, protegido contra error</p> <p>PT Mão-de-amigo, amarelo aluminio, com dispositivo de segurança</p> <p>RU Соединительная головка, желтая крышка Алюминиевая, защищенная от случайного спутывания</p>	M 16 x 1,5, repl. Wabco: 952 200 022 0	000 429 7930	<p>02.21306</p> 
				
NG/MK/SK	<p>EN Palm coupling, red lid alu, error safe alu, error safe</p> <p>DE Kupplungskopf, roter Deckel Alu, vertauschgesichert</p> <p>FR Main d'accouplement, couvercle rouge alu, sans risque</p> <p>ES Cabeza de acoplamiento, Tapa roja aluminio, protegido contra error</p> <p>PT Mão-de-amigo, vermelho aluminio, com dispositivo de segurança</p> <p>RU Соединительная головка, красная крышка Алюминиевая, защищенная от случайного спутывания</p>	M 16 x 1,5, repl. Wabco: 952 200 021 0	000 429 7730	<p>02.21304</p> 
				
NG/MK/SK	<p>EN Palm coupling, automatic shutter</p> <p>DE Kupplungskopf, automatischer Verschluss</p> <p>FR Main d'accouplement, avec clapet</p> <p>ES Cabeza de acoplamiento, cierre automático</p> <p>PT Mão-de-amigo, automática</p> <p>RU Соединительная головка, автоматический замок</p>	M 16 x 1,5, repl. Wabco: 952 200 222 0		<p>02.23382</p> 
				
NG/MK/SK	<p>EN Palm coupling, automatic shutter</p> <p>DE Kupplungskopf, automatischer Verschluss</p> <p>FR Main d'accouplement, avec clapet</p> <p>ES Cabeza de acoplamiento, cierre automático</p> <p>PT Mão-de-amigo, automática</p> <p>RU Соединительная головка, автоматический замок</p>	M 16 x 1,5, repl. Wabco: 952 200 221 0		<p>02.23383</p> 
				

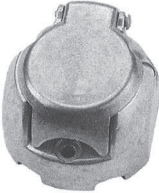







Application	Description	Details	Ref.	Erqo No.
NG/MK/SK	<ul style="list-style-type: none"> EN Palm coupling, red lid automatic shutter DE Kupplungskopf, roter Deckel automatischer Verschluss FR Main d'accouplement, couvercle rouge fermeture automatique ES Cabeza de acoplamiento, Tapa roja cierre automático PT Mão-de-amigo, vermelho bloqueio automático RU Соединительная головка, красная крышка автоматический замок 	M 22 x 1,5, repl. Wabco: 452 200 211 0		02.23384 
				
NG/MK/SK	<ul style="list-style-type: none"> EN Palm coupling, yellow lid automatic shutter DE Kupplungskopf, gelber Deckel automatischer Verschluss FR Main d'accouplement, couvercle jaune fermeture automatique ES Cabeza de acoplamiento, Tapa amarilla cierre automático PT Mão-de-amigo, amarelo bloqueio automático RU Соединительная головка, желтая крышка автоматический замок 	M 22 x 1,5, repl. Wabco: 452 200 212 0		02.23385 
				
NG/MK/SK	<ul style="list-style-type: none"> EN Rubber, coupling head for all palm couplings DE Ersatzgummi, Kupplungskopf für alle Kupplungsköpfe FR Caoutchouc de rechange, tête d'embrayage pour toutes mains d'accouplement ES Goma de repuesto, Cabeza de acoplamiento para todas las cabezas de acoplamiento PT Espaçador, borracha para todos os modelos de acoplamentos RU Запасной резиновый элемент, соединительная головка для всех соединительных головок 		000 429 2184	02.21341 
				
NG/MK/SK	<ul style="list-style-type: none"> EN Air spiral DE Luftspirale FR Spirale air ES Espiral de aire PT Mangueira serviço RU Воздушный спиральный шланг 	M 16 x 1,5 / yellow / 18 windings		02.23386 
				



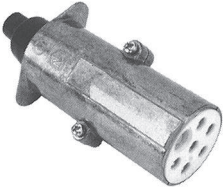





Application	Description	Details	Ref.	Erqo No.
NG/MK/SK	<ul style="list-style-type: none"> EN Air spiral DE Luftspirale FR Spirale air ES Espiral de aire PT Mangueira serviço RU Воздушный спиральный шланг 	M 16 x 1,5 / red / 22 windings		02.23387
				
NG/MK/SK	<ul style="list-style-type: none"> EN Air spiral DE Luftspirale FR Spirale air ES Espiral de aire PT Mangueira serviço RU Воздушный спиральный шланг 	M 22 x 1,5 / yellow / 19 windings		02.23388
				
NG/MK/SK	<ul style="list-style-type: none"> EN Air spiral DE Luftspirale FR Spirale air ES Espiral de aire PT Mangueira serviço RU Воздушный спиральный шланг 	M 16 x 1,5 / red / 18 windings		02.23389
				
NG/MK/SK	<ul style="list-style-type: none"> EN Air spiral DE Luftspirale FR Spirale air ES Espiral de aire PT Mangueira serviço RU Воздушный спиральный шланг 	M 22 x 1,5 / red / 19 windings		02.23390
				
NG/MK/SK	<ul style="list-style-type: none"> EN Air spiral DE Luftspirale FR Spirale air ES Espiral de aire PT Mangueira serviço RU Воздушный спиральный шланг 	M 16 x 1,5 / yellow / 22 windings		02.23391
				

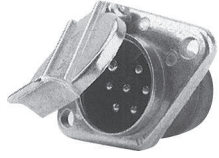

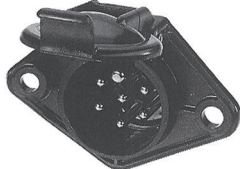

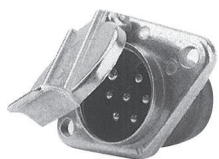

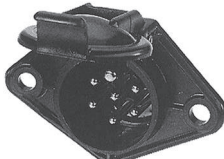

THE ORIGINAL NUMBERS OF THE VEHICLE MANUFACTURER MAY BE USED FOR COMPARISON PURPOSES ONLY AND MUST NOT BE MENTIONED ON INVOICES TO VEHICLE OWNERS.

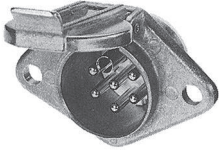



Application	Description	Details	Ref.	Erqo No.
NG/MK/SK	<ul style="list-style-type: none"> EN Plug 12V, Aluminium DE Stecker 12V, Aluminium FR Fiche 12V, aluminium ES Conector 12V, aluminio PT Bujão metal 12V, alumínio RU Штепсельная вилка 12В, Алюминий 	12V; Type N; ISO 1724		02.23392
				
NG/MK/SK	<ul style="list-style-type: none"> EN Cable connection 12V DE Kabelspirale 12V FR Câble 12V ES Serpentina eléctrica 12V PT Cabo conexão 12V RU Кабельная спираль 12В 	12V; 7 pol. Type N; ISO 1724; 3500 mm		02.23393
				
NG/MK/SK	<ul style="list-style-type: none"> EN Socket 12V, Aluminium DE Steckdose 12V, Aluminium FR Prise 12V, aluminium ES Conector de enchufe 12V, aluminio PT Tomada 12V, alumínio RU Штекерный разъем 12В, Алюминий 	12V; Type N; ISO 1724		02.23394
				
NG/MK/SK	<ul style="list-style-type: none"> EN Plug, 6-24V, plastic DE Stecker, 6-24V, Kunststoff FR Fiche, 6-24V, plastique ES Conector, 6-24V, plástico PT Bujão, 6-24V, plástico RU Штепсельная вилка, 6-24В, пластмассовая 	6-24V; 3 pol.		02.23395
				
NG/MK/SK	<ul style="list-style-type: none"> EN Socket, 6-24V, plastic DE Steckdose, 6-24V, Kunststoff FR Prise, 6-24V, plastique ES Conector de enchufe, 6-24V, plástico PT Tomada, 6-24V, plástico RU Штекерный разъем, 6-24В, пластмассовый 	6-24V; 3 pol.		02.23396
				



THE ORIGINAL NUMBERS OF THE VEHICLE MANUFACTURER MAY BE USED FOR COMPARISON PURPOSES ONLY AND MUST NOT BE MENTIONED ON INVOICES TO VEHICLE OWNERS.

Application	Description	Details	Ref.	Erqo No.
NG/MK/SK	<ul style="list-style-type: none"> EN Plug 24V, aluminium Screw terminal DE Stecker 24V, Aluminium Schraubanschluss FR Fiche 24V, aluminium raccord à vis ES Conector 24V, aluminio terminal roscado PT Bujão 24V, Alumínio terminal roscado RU Штепсельная вилка 24В, Алюминий резьбовое соедин 	24V; Type N; 7 pol. ISO 1185		02.23397
				
NG/MK/SK	<ul style="list-style-type: none"> EN Plug, 24V, aluminium Screw terminal DE Stecker, 24V, Aluminium Schraubanschluss FR Fiche, 24V, aluminium raccord à vis ES Conector, 24V, aluminio terminal roscado PT Bujão, 24V, alumínio terminal roscado RU Штепсельная вилка, 24В, Алюминий резьбовое соедин 	24V; TypeS; ISO 3731, 7 pole		02.23398
				
NG/MK/SK	<ul style="list-style-type: none"> EN Plug, 24V, plastic DE Stecker, 24V, Kunststoff FR Fiche, 24V, plastique ES Conector, 24V, plástico PT Bujão, 24V, plástico RU Штепсельная вилка, 24В, пластмассовая 	24V; Type N; 7 pol. ISO 1185		02.23399
				
NG/MK/SK	<ul style="list-style-type: none"> EN Plug, 24V, plastic DE Stecker, 24V, Kunststoff FR Fiche, 24V, plastique ES Conector, 24V, plástico PT Bujão, 24V, plástico RU Штепсельная вилка, 24В, пластмасса 	24V; Type S; 7 pol. ISO 3731		02.23400
				





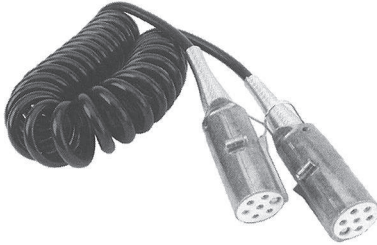





Application	Description	Details	Ref.	Erqo No.
NG/MK/SK	<ul style="list-style-type: none"> EN Socket, 24V, Aluminium Screw terminal DE Steckdose, 24V, Aluminium Schraubanschluss FR Socle, 24V, aluminium raccord à vis ES Conector de enchufe, 24V, aluminio terminal roscado PT Tomada, 24V, alumínio terminal roscado RU Штекерный разъем, 24 В, алюминий резьбовое соедин 	24V; Type N; ISO 1185, 7 pole		02.23401 
NG/MK/SK	<ul style="list-style-type: none"> EN Socket, 24V, plastic, screw connection DE Steckdose, 24V, Kunststoff, Schraubanschluss FR Prise, 24V, plastique, connexion à vis ES Conector de enchufe, 24V, plástico, terminal roscado PT Tomada, 24V, plástico, terminal roscado RU Штекерный разъем, 24В, пластик, резьбовое соединен 	24V; Type N; 7 pol. ISO 1185		02.23402 
NG/MK/SK	<ul style="list-style-type: none"> EN Socket, 24V, aluminium, flat pin connect. DE Steckdose, 24V, Aluminium, Flachsteckanschluss FR Prise, 24V, aluminium, connexion brache plate ES Conector de enchufe, 24V, aluminio, terminal plano PT Tomada, 24V, alumínio, terminal plano RU Штекерный разъем, 24В, алюминиевый 	24V; Type N; 7 pol. ISO 1185		02.23403 
NG/MK/SK	<ul style="list-style-type: none"> EN Socket, 24V, plastic, crimp contacts DE Steckdose, 24V, Kunststoff, Crimp Kontakte FR Prise, 24V, plastique, connexion à sertissage ES Conector de enchufe, 24V, plástico, terminal prensado PT Tomada, 24V, plástico, terminal prensado RU Штекерный разъем, 24В, пластик, соединение обжимом 	24V; Type N; 7 pol. ISO 1185		02.23404 

Application	Description	Details	Ref.	Erqo No.
NG/MK/SK	<ul style="list-style-type: none"> EN Socket, 24V, aluminium, screw connection DE Steckdose, Aluminium, Schraubanschluss FR Prise, 24V, aluminium, connexion à vis ES Conector de enchufe, 24V, aluminio, terminal roscado PT Tomada, 24V, alumínio, terminal roscado RU Штекерный разъем, 24В, алюминий, резьбовое соедин 	24V; Type S; 7 pol. ISO 3731		02.23405
				
NG/MK/SK	<ul style="list-style-type: none"> EN Socket, 24V, plastic, screw connection DE Steckdose, 24V, Kunststoff, Schraubanschluss FR Prise, 24V, plastique, connexion à vis ES Conector de enchufe, 24V, plástico, terminal roscado PT Tomada, 24V, plástico, terminal roscado RU Штекерный разъем, 24В, пластик, резьбовое соединен 	24V; Type S; 7 pol. ISO 3731		02.23406
				
NG/MK/SK	<ul style="list-style-type: none"> EN Cable protection cap DE Leitungsschutzkappe FR Protection de câble ES Capuchón protector PT Capa proteção do cabo RU Защитный колпачок кабеля 			02.23407
				
NG/MK/SK	<ul style="list-style-type: none"> EN Electrical coil, 24V, 3500 mm DE Elektrowendelleitung, 24V, 3500 mm FR Câble électrique, 24V, 3500 mm ES Serpentina eléctrica, 24V, 3500 mm PT Cabo conecção, 24V, 3500 mm RU Спиральный электропровод, 24В, 3500 мм 	24V; Type N; 7 pol. ISO 1185; 3500 mm		02.23408
				
NG/MK/SK	<ul style="list-style-type: none"> EN Electrical coil, 24V, 4000 mm DE Elektrowendelleitung, 24V, 4000 mm FR Câble électrique, 24V, 4000 mm ES Serpentina eléctrica, 24V, 4000 mm PT Cabo conecção, 24V, 4000 mm RU Спиральный электропровод, 24В, 4000 мм 	24V; Type N; ISO 1185, 7 pol. 4000 mm		02.23409
				

Application	Description	Details	Ref.	Erqo No.
NG/MK/SK	<ul style="list-style-type: none"> EN Electrical coil, 24V, 3500 mm DE Elektrowendelleitung, 24V, 3500 mm FR Câble électrique, 24V, 3500 mm ES Serpentina eléctrica, 24V, 3500 mm PT Cabo conexão, 24V, 3500 mm RU Спиральный электропровод, 24В, 3500 мм 	24V; Type N; 7 pol. ISO 1185; 3500 mm		<p>02.23410</p> 
				
NG/MK/SK	<ul style="list-style-type: none"> EN Electrical coil, 24V, 4500 mm DE Elektrowendelleitung, 24V, 4500 mm FR Câble électrique, 24V, 4500 mm ES Serpentina eléctrica, 24V, 4500 mm PT Cabo conexão, 24V, 4500 mm RU Спиральный электропровод, 24В, 4500 мм 	24V; Type N; 7 pol. ISO 1185; 4500 mm		<p>02.23411</p> 
				
NG/MK/SK	<ul style="list-style-type: none"> EN Electrical coil, 24V, 5000 mm DE Elektrowendelleitung, 24V, 5000 mm FR Câble électrique, 24V, 5000 mm ES Serpentina eléctrica, 24V, 5000 mm PT Cabo conexão, 24V, 5000 mm RU Спиральный электропровод, 24В, 5000 мм 	24V; Type N; 7 pol. ISO 1185; 5000 mm		<p>02.23412</p> 
				

Application	Description	Details	Ref.	Erqo No.
NG/MK/SK	<ul style="list-style-type: none"> EN Electrical coil, 24V, 3500 mm, aluminium DE Elektrowendelleitung, 24V, 3500 mm, Aluminium FR Câble électrique, 24V, 3500 mm, aluminium ES Serpentina eléctrica, 24V, 3500 mm, aluminio PT Cabo conexão, 24V, 3500 mm, alumínio RU Спиральный электропровод, 24В, 3500 мм, алюминиевый 	24V; Type S; 7 pol. ISO 3731; 3500 mm		02.23413
				
NG/MK/SK	<ul style="list-style-type: none"> EN Electrical coil, 24V, 3500 mm, plastic DE Elektrowendelleitung, 24V, 3500 mm, Kunststoff FR Câble électrique, 24V, 3500 mm, plastique ES Serpentina eléctrica, 24V, 3500 mm, plástico PT Cabo conexão, 24V, 3500 mm, plástico RU Спиральный электропровод, 24В, 3500 мм, пластмассовый 	24V; Type S; 7 pol. ISO 3731; 3500 mm		02.23414
				
NG/MK/SK	<ul style="list-style-type: none"> EN Electrical coil, 24V, 4500 mm DE Elektrowendelleitung, 24V, 4500 mm FR Câble électrique, 24V, 4500 mm ES Serpentina eléctrica, 24V, 4500 mm PT Cabo conexão, 24V, 4500 mm RU Спиральный электропровод, 24В, 4500 мм 	24V; Type S; 7 pol. ISO 3731; 4500 mm		02.23415
				
NG/MK/SK	<ul style="list-style-type: none"> EN Electrical coil, 24V, 5000 mm DE Elektrowendelleitung, 24V, 5000 mm FR Câble électrique, 24V, 5000 mm ES Serpentina eléctrica, 24V, 5000 mm PT Cabo conexão, 24V, 5000 mm RU Спиральный электропровод, 24В, 5000 мм 	24V; Type S; 7 pol. ISO 3731; 5000 mm		02.23416
				

THE ORIGINAL NUMBERS OF THE VEHICLE MANUFACTURER MAY BE USED FOR COMPARISON PURPOSES ONLY AND MUST NOT BE MENTIONED ON INVOICES TO VEHICLE OWNERS.









Application	Description	Details	Ref.	Erqo No.
NG/MK/SK	<ul style="list-style-type: none"> EN Plug, 24V, 15 pins DE Stecker, 24V, 15 polig FR Fiche, 24V, 15 broches ES Conector, 24V, 15 contactos PT Vujão, 24V, 15 pinos RU Штепсельная вилка, 24В, 15-контактный 	24V; 15 pol. ISO 12098		02.23417 
				
NG/MK/SK	<ul style="list-style-type: none"> EN Socket, 24V, 15 pins DE Steckdose, 24V, 15 polig FR Prise, 24V, 15 broches ES Conector de enchufe, 24V, 15 contactos PT Tomada, 24V, 15 pólos RU Штекерный разъем, 24В, 15-контактный 	24V; 15 pol. ISO 12098		02.23418 
				
NG/MK/SK	<ul style="list-style-type: none"> EN Socket, 24V, 15 pins DE Steckdose, 24V, 15 polig FR Prise, 24V, 15 broches ES Conector de enchufe, 24V, 15 contactos PT Tomada, 24V, 15 pólos RU Штекерный разъем, 24В, 15-контактный 	24V; 15 pol. ISO 12098; 90°		02.23419 
				
NG/MK/SK	<ul style="list-style-type: none"> EN Electrical coil, 24V, 15 pole, 3500 mm DE Elektrowendelleitung, 24V, 15 polig, 3500 mm FR Câble électrique, 24V, 15 pôles, 3500 mm ES Serpentina eléctrica, 24V, 15 polos, 3500 mm PT Cabo conexão, 24V, 15 pólos, 3500 mm RU Спиральный электропровод, 24В, 15-контакт, 3500 мм 	24V; 15 pol. ISO 12098; 3500 mm		02.23420 
				
NG/MK/SK	<ul style="list-style-type: none"> EN Plug, 24V, ABS, screw connection DE Stecker, 24V, ABS, Schraubanschluss FR Fiche, 24V, ABS, connexion à vis ES Conector, 24V, ABS, terminal roscado PT Vujão, 24V, ABS, terminal roscado RU Штепсельная вилка, 24В, А В S 	24V; ABS; 5 pol. ISO 7638		02.23421 
				



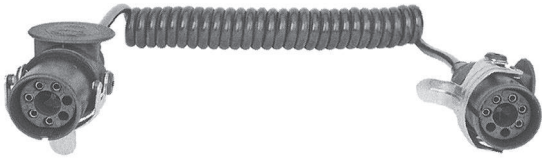





Application	Description	Details	Ref.	Erqo No.
NG/MK/SK	<ul style="list-style-type: none"> EN Plug, 24V, ABS, crimp connection DE Stecker, 24V, ABS, Crimp Anschluss FR Fiche, 24V, ABS, connexion à sertissage ES Conector, 24V, ABS, terminal prensado PT Vujão, 24V, ABS, terminal prensado RU Штепсельная вилка, 24В, ABS, соединение обжимом 	24V; ABS; 5 pol. ISO 7638		02.23422
				
			Sample	
NG/MK/SK	<ul style="list-style-type: none"> EN Plug, 24V, EBS, Screw connection DE Stecker, 24V, EBS, Schraubanschluss FR Fiche, 24V, EBS, connexion à vis ES Conector, 24V, EBS, terminal roscado PT Vujão, 24V, EBS, terminal roscado RU Штепсельная вилка, 24В, EBS, резьбовое соединение 	24V; EBS; 7 pol. ISO 7638		02.23423
				
NG/MK/SK	<ul style="list-style-type: none"> EN Plug, 24V, EBS, Crimp connection DE Stecker, 24V, EBS, Crimp Anschluss FR Fiche, 24V, EBS, connexion à sertissage ES Conector, 24V, EBS, terminal prensado PT Vujão, 24V, EBS, terminal prensado RU Штепсельная вилка, 24В, EBS, соединение обжимом 	24V; EBS; 7 pol. ISO 7638		02.23424
				
NG/MK/SK	<ul style="list-style-type: none"> EN Socket, 24V, ABS, Screw connection DE Steckdose, 24V, ABS, Schraubanschluss FR Prise, 24V, ABS, connexion à vis ES Conector de enchufe, 24V, ABS, terminal roscado PT Tomada, 24V, ABS, terminal roscado RU Штекерный разъем, 24В, ABS, резьбовое соединение 	24V; ABS; 5 pol. ISO 7638		02.23425
				
NG/MK/SK	<ul style="list-style-type: none"> EN Socket, 24V, ABS, Crimp connection DE Steckdose, 24V, ABS, Crimp Anschluss FR Prise, 24V, ABS, connexion à sertissage ES Conector de enchufe, 24V, ABS, terminal prensado PT Tomada, 24V, ABS, terminal prensado RU Штекерный разъем, 24В, ABS, соединение обжимом 	24V; ABS; 5 pol. ISO 7638		02.23426
				
			Sample	

THE ORIGINAL NUMBERS OF THE VEHICLE MANUFACTURER MAY BE USED FOR COMPARISON PURPOSES ONLY AND MUST NOT BE MENTIONED ON INVOICES TO VEHICLE OWNERS.

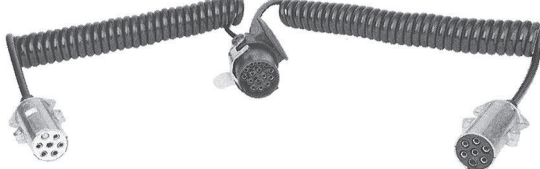
Application	Description	Details	Ref.	Erqo No.
NG/MK/SK	<ul style="list-style-type: none"> EN Socket, 24V, EBS, Screw connection DE Steckdose, 24V, EBS, Schraubanschluss FR Prise, 24V, EBS, connexion à vis ES Conector de enchufe, 24V, EBS, terminal roscado PT Tomada, 24V, EBS, terminal roscado RU Штекерный разъем, 24В: EBS, резьбовое соединение 	24V; EBS; 7 pol. ISO 7638		02.23427 
NG/MK/SK	<ul style="list-style-type: none"> EN Socket, 24V, EBS, Crimp connection DE Steckdose, 24V, EBS, Crimp Anschluss FR Prise, 24V, EBS, connexion à sertissage ES Conector de enchufe, 24V, EBS, terminal prensado PT Tomada, 24V, EBS, terminal prensado RU Штекерный разъем, 24В, EBS, соединение обжимом 	24V; EBS; 7 pol. ISO 7638		02.23428 
NG/MK/SK	<ul style="list-style-type: none"> EN Socket, 24V, EBS, Screw connection DE Steckdose, 24V, EBS, Schraubanschluss FR Prise, 24V, EBS, connexion à vis ES Conector de enchufe, 24V, EBS, terminal roscado PT Tomada, 24V, EBS, terminal roscado RU Штекерный разъем, 24В, EBS, резьбовое соединение 	24V; EBS; 7 pol. ISO 7638; 90°		02.23429 
NG/MK/SK	<ul style="list-style-type: none"> EN Socket, 24V, ABS, Screw connection DE Steckdose, 24V, ABS, Schraubanschluss FR Prise, 24V, ABS, connexion à vis ES Conector de enchufe, 24V, ABS, terminal roscado PT Tomada, 24V, ABS, terminal roscado RU Штекерный разъем, 24В, ABS, резьбовое соединение 	24V; ABS; 5 pol. ISO 7638; 90°		02.23430 
NG/MK/SK	<ul style="list-style-type: none"> EN Park socket, ABS DE Parkdose, ABS FR Prise, ABS ES Conector eléctrico, ABS PT Soquete, ABS RU Штекерный разъем, ABS 	ISO 12098 / ISO 7638		02.23431 

THE ORIGINAL NUMBERS OF THE VEHICLE MANUFACTURER MAY BE USED FOR COMPARISON PURPOSES ONLY AND MUST NOT BE MENTIONED ON INVOICES TO VEHICLE OWNERS.







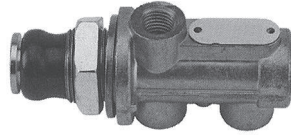

Application	Description	Details	Ref.	Erqo No.
NG/MK/SK	<p>EN Electrical coil, ABS, 4500 mm, without plugs</p> <p>DE Elektrowendelleitung, ABS, 4500 mm, ohne Stecker</p> <p>FR Câble électrique, ABS, 4500 mm, sans prise</p> <p>ES Serpentina eléctrica, ABS, 4500 mm, sólo cable</p> <p>PT Cabo conexão, ABS, 4500 mm, sem bujao</p> <p>RU Спиральный электропровод, ABS, 4500 мм, без штекера</p>	24V; ABS; 5 pol. ISO 7638; 4500 mm		02.23432
				
NG/MK/SK	<p>EN Electrical coil, 24V, ABS, 3500 mm</p> <p>DE Elektrowendelleitung, 24V, ABS, 3500 mm</p> <p>FR Câble électrique, 24V, ABS, 3500 mm</p> <p>ES Serpentina eléctrica, 24V, ABS, 3500 mm</p> <p>PT Cabo conexão, 24V, ABS, 3500 mm</p> <p>RU Спиральный электропровод, 24В, ABS, 3500 мм</p>	24V; ABS; 5 pol. ISO 7638; 3500 mm		02.23433
				
NG/MK/SK	<p>EN Electrical coil, 24V, ABS, 4500 mm</p> <p>DE Elektrowendelleitung, 24V, ABS, 4500 mm</p> <p>FR Câble électrique, 24V, ABS, 4500 mm</p> <p>ES Serpentina eléctrica, 24V, ABS, 4500 mm</p> <p>PT Cabo conexão, 24V, ABS, 4500 mm</p> <p>RU Спиральный электропровод, 24В, ABS, 4500 мм</p>	24V; ABS; 5 pol. ISO 7638; 4500 mm	000 540 3839	02.23434
				
				Sample
NG/MK/SK	<p>EN Electrical coil, 24V, EBS, 3500 mm</p> <p>DE Elektrowendelleitung, 24V, EBS, 3500 mm</p> <p>FR Câble électrique, 24V, EBS, 3500 mm</p> <p>ES Serpentina eléctrica, 24V, EBS, 3500 mm</p> <p>PT Cabo conexão, 24V, EBS, 3500 mm</p> <p>RU Спиральный электропровод, 24В, EBS, 3500 мм</p>	24V; EBS; 7 pol. ISO 7638; 3500 mm		02.23435
				

Application	Description	Details	Ref.	Erqo No.
NG/MK/SK	<ul style="list-style-type: none"> EN Electrical adapter coil, 24V, 3500 mm DE Adapterwendelleitung, 24V, 3500 mm FR Câble adaptateur, 24V, 3500 mm ES Serpentina eléctrica, 24V, 3500 mm PT Cabo conexão, 24V, 3500 mm RU Кабельная спираль, 24В, 3500 мм 	15 pol to 2 x 7 pol.; Type N/S; 3500 mm		02.23436 
NG/MK/SK	<ul style="list-style-type: none"> EN Electrical adapter coil, 24V, 4500 mm DE Adapterwendelleitung, 24V, 4500 mm FR Câble adaptateur, 24V, 4500 mm ES Serpentina eléctrica, 24V, 4500 mm PT Cabo conexão, 24V, 4500 mm RU Кабельная спираль, 24В, 4500 мм 	15 pol to 2 x 7 pol.; Type N/S; 4500 mm		02.23437 
NG/MK/SK	<ul style="list-style-type: none"> EN Electrical adapter coil, 24V, 3500 mm DE Adapterwendelleitung, 24V, 3500 mm FR Câble adaptateur, 24V, 3500 mm ES Serpentina eléctrica, 24V, 3500 mm PT Cabo conexão, 24V, 3500 mm RU Кабельная спираль, 24В, 3500 мм 	15 pol to 2 x 7 pol.; Type N/S; 3500 mm		02.23438 
NG/MK/SK	<ul style="list-style-type: none"> EN Electrical adapter coil, 24V, 3500 mm DE Adapterwendelleitung, 24V, 3500 mm FR Câble adaptateur, 24V, 3500 mm ES Serpentina eléctrica, 24V, 3500 mm PT Cabo conexão, 24V, 3500 mm RU Кабельная спираль, 24В, 3500 мм 	15 pol to 2 x 7 pol.; Type N/S; 3500 mm		02.23439 

Application	Description	Details	Ref.	Erqo No.
NG/MK/SK	<ul style="list-style-type: none"> EN Electrical adapter coil, 24V, 3500 mm DE Adapterwendelleitung, 24V, 3500 mm FR Câble adaptateur, 24V, 3500 mm ES Serpentina eléctrica, 24V, 3500 mm PT Cabo conexão, 24V, 3500 mm RU Кабельная спираль, 24В, 3500 мм 	15 pol to 2x7 pol.; Type N/S; 3500 mm		02.23440
				
NG/MK/SK	<ul style="list-style-type: none"> EN Adapter connector, 15 pole, 2x7 pole DE Adapter, 15 polig, 2x7 polig FR Adaptateur, 15 pôles, 2x7 pôles ES Adaptador, 15 polos, 2x7 polos PT Conexão, 15 pólos, 2x7 pólos RU Адаптер, 15-контактный, 2x7-контактный 	15 pol to 2x7 pol.; Type N/S		02.23441
				

Application	Description	Details	Ref.	Erqo No.
NG	<p>(EN) Exhaust brake valve, with plastic tappet new version</p> <p>(DE) Motorbremsventil, mit Kunststoffstößel neue Ausführung</p> <p>(FR) Valve 3 voies, avec bouchon en plastique nouvelle version</p> <p>(ES) Válvula de freno motor, con taqué plástico nueva versión</p> <p>(PT) Válvula freio motor, com haste plástica nova versão</p> <p>(RU) Клапан моторного тормоза, с пластиковым толкателем нового типа</p>	repl. Wabco 463 013 114 0	000 434 2401	<p>02.21520</p> 
				
NG	<p>(EN) Exhaust brake valve, with steel tappet old version</p> <p>(DE) Motorbremsventil, mit Stahlstößel alte Ausführung</p> <p>(FR) Soupape de frein moteur, avec bouchon acier ancienne version</p> <p>(ES) Válvula de freno motor, con taqué de acero versión antigua</p> <p>(PT) Válvula freio motor, com haste aço versão antiga</p> <p>(RU) Клапан моторного тормоза, со стальным толкателем старое исполнение</p>		000 434 2401	<p>02.21521</p> 
				
NG	<p>(EN) Exhaust brake valve, with plastic tappet new version</p> <p>(DE) Motorbremsventil, mit Kunststoffstößel neue Ausführung</p> <p>(FR) Soupape de frein moteur, avec bouchon en plastique nouvelle version</p> <p>(ES) Válvula de freno motor, con taqué plástico nueva versión</p> <p>(PT) Válvula freio motor, com haste plástica nova versão</p> <p>(RU) Клапан моторного тормоза, с пластиковым толкателем нового типа</p>	repl. Wabco 463 013 116 0	000 434 3101	<p>02.21523</p> 
				

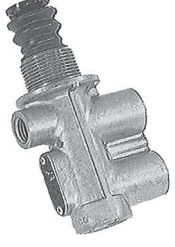
THE ORIGINAL NUMBERS OF THE VEHICLE MANUFACTURER MAY BE USED FOR COMPARISON PURPOSES ONLY AND MUST NOT BE MENTIONED ON INVOICES TO VEHICLE OWNERS.

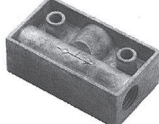
Application	Description	Details	Ref.	Erqo No.
NG	<ul style="list-style-type: none"> EN Exhaust brake valve, with steel tappet old version DE Motorbremsventil, mit Stahlstößel alte Ausführung FR Soupape de frein moteur, avec bouchon acier ancienne version ES Válvula de freno motor, con taqué de acero versión antigua PT Válvula freio motor, com haste aço versão antiga RU Клапан моторного тормоза, со стальным толкателем старое исполнение 		000 434 3101	02.21524 
				
NG	<ul style="list-style-type: none"> EN Lock nut DE Kontermutter FR Ecrou ES Contratuerca PT Porca trava RU Контргайка 	M 26 x 1,5	074305 026202	02.22925 
				
BM 650, 651/652/653/654, 655/656/657/658, 659	<ul style="list-style-type: none"> EN Stop valve DE Stoppventil FR Soupape d'arrêt ES Válvula de parada PT Válvula freio motor RU Остановочный клапан 		003 997 7536	02.22616 
				
BM 620/621/623/624, 625, 645/646/648/649, 652/653/654/655, 656/657/658/659	<ul style="list-style-type: none"> EN Control valve DE Kontrollventil FR Soupape de contrôle ES Válvula de control PT Válvula controle da válvula split RU Контрольный клапан 		000 434 3801	02.21526 
				
BM 619, 623/624/625, 648, 650/651/652/653, 654/655/657/658, 659	<ul style="list-style-type: none"> EN Valve DE Ventil FR Soupape ES Válvula PT Válvula RU Клапан 		001 260 4957	02.20477 
				





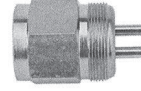

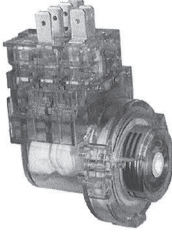

THE ORIGINAL NUMBERS OF THE VEHICLE MANUFACTURER MAY BE USED FOR COMPARISON PURPOSES ONLY AND MUST NOT BE MENTIONED ON INVOICES TO VEHICLE OWNERS.

Application	Description	Details	Ref.	Erqo No.
BM 397	<ul style="list-style-type: none">EN SwitchDE SchalterFR CommodoES InterruptorPT InterruptorRU Выключатель	0,1 -0,5 bar; M12 x 1,5 / M27 x 1	003 545 9214	02.22005 

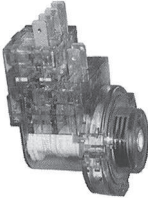

Application	Description	Details	Ref.	Erqo No.
BM 383/397, BM 616/617/619/620, 621/623/624/625, 645/646/647/648, 649	<ul style="list-style-type: none"> EN Ignition lock DE Zündschloss FR Neiman ES Cerradura de encendido PT Trava ignição sem cilindro RU Замок зажигания 		001 462 1130	02.21652 
BM 383/397, BM 616/617/619/620, 621/623/624/625, 645/646/647/648, 649	<ul style="list-style-type: none"> EN Lock cylinder DE Schließzylinder FR Barillet de Neiman ES Cilindro de cierre PT Miolo maçaneta RU Цилиндр замка 		381 460 0004	02.21531 
BM 383/397, BM 616/617/619/620, 621/623/624/625, 645/646/647/648, 649	<ul style="list-style-type: none"> EN Ignition switch DE Zündschalter FR Interrupteur allumage ES Interruptor de arranque PT Miolo chave ignição RU Выключатель зажигания 		000 545 5413	02.21989 
BM 625/650/651/652, 653/654/655/656, 657/658/659	<ul style="list-style-type: none"> EN Steering lock DE Zündschloss FR Neiman ES Cerradura de encendido PT Bloqueio direção RU Замок зажигания 		650 462 0230	02.21653 
BM 625/650/651/652, 653/654/655/656, 657/658/659	<ul style="list-style-type: none"> EN Lock cylinder DE Schließzylinder FR Cylindre de fermeture ES Cilindro de cierre PT Miolo maçaneta RU Цилиндр замка 		667 460 0304	02.21532 









THE ORIGINAL NUMBERS OF THE VEHICLE MANUFACTURER MAY BE USED FOR COMPARISON PURPOSES ONLY AND MUST NOT BE MENTIONED ON INVOICES TO VEHICLE OWNERS.

Application	Description	Details	Ref.	Erqo No.
BM 625/650/651/652, 653/654/655/656, 657/658/659, K004869>	<ul style="list-style-type: none"> EN Ignition switch DE Startschalter FR Interrupteur de démarrage ES Interruptor de arranque PT Miolo chave ignição RU Выключатель стартера 		655 545 0008	02.21961 
BM 625/650/651/652, 653/654/655/656, 657/658/659 >K004868	<ul style="list-style-type: none"> EN Ignition switch DE Startschalter FR Interrupteur de démarrage ES Interruptor de arranque PT Miolo chave ignição RU Выключатель стартера 		667 545 0013	02.21991 
8 BM 381/383/385/385, 389/393/395 BM 645/646/647/648, 649,650/651/652, 653/654/655/656, 657/658/659	<ul style="list-style-type: none"> EN Steering column, complete DE Lenkspindel, komplett FR Colonne de direction, complète ES Columna de dirección, completa PT Coluna direção, completa RU Вал рулевого управления, в сборе 		650 460 0609	02.21570 
BM 620/621/622/623, 625/645/646/647, 648/649/650/651, 652/653/654/655, 656/657/658/659	<ul style="list-style-type: none"> EN Steering column DE Lenksäule FR Colonne de direction ES Columna de dirección PT Coluna direção RU Рулевая колонка 		655 460 0809	02.21571 

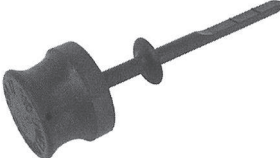



THE ORIGINAL NUMBERS OF THE VEHICLE MANUFACTURER MAY BE USED FOR COMPARISON PURPOSES ONLY AND MUST NOT BE MENTIONED ON INVOICES TO VEHICLE OWNERS.

Application	Description	Details	Ref.	Erqo No.
BM 381/383/385/385/389, 393/395 BM 620/621/622/623/625, 645/646/647/648/649 650/651/652/653/654 655/656/657/658/659	<ul style="list-style-type: none"> EN Universal joint, new version DE Kreuzgelenk, neue Ausführung FR Joint de cardan à croisillon, nouvelle version ES Articulación cardán, nueva versión PT Cruzeta direção, nova versão RU Карданный шарнир с крестовиной, нового типа 		000 460 0157	02.21628 
BM 381/383/385/385, 389/393/395 BM 616/617/619/620, 621/622/623/625, 645/646/647/648, 649	<ul style="list-style-type: none"> EN Boot DE Manschette FR Manchon ES Retén PT Guarda-pó alavanca cambio RU Манжета 		381 462 1196	02.21658 
BM 381/383/385/385, 389/393/395 BM 616/617/619/620, 621/622/623/625, 645/646/647/648, 649	<ul style="list-style-type: none"> EN Boot DE Manschette FR Manchon ES Retén PT Guarda-pó alavanca cambio RU Манжета 		387 461 0396	02.21650 

Application	Description	Details	Ref.	Erqo No.
BM 380/381/383/385, 387/389, 393/395, 615/616/617/619, 620/621/622/623, 624/625, 645/646/647/648, 649	<ul style="list-style-type: none"> EN Oil container DE Ölbehälter FR Réservoir d'huile ES Depósito de aceite PT Reservatório óleo RU Резервуар для масла 	repl.ZF 7632 472 136	000 466 4502	02.21664 
BM 650/651/652/653, 654/655/656/657, 658/659	<ul style="list-style-type: none"> EN Oil container DE Ölbehälter FR Réservoir d'huile ES Depósito de aceite PT Reservatório óleo RU Резервуар для масла 		000 466 6202	02.21665 
NG/MK/SK	<ul style="list-style-type: none"> EN Oil filter, steering DE Ölfilter, Lenkung FR Filtre à huile, direction ES Filtro de aceite, dirección PT Elemento filtro óleo, direção RU Масляный фильтр, управление 	repl. M+H: H 601/4	000 466 2804	02.21668 
BM 387/389/395, 625	<ul style="list-style-type: none"> EN Oil filter, steering DE Ölfilter, Lenkung FR Filtre à huile, direction ES Filtro de aceite, dirección PT Filtro reservatório, direção RU Масляный фильтр, управление 	repl. M+H: P 919/7	000 466 0004	02.21666 
NG/MK/SK	<ul style="list-style-type: none"> EN Gasket, oil container DE Dichtung, Ölbehälter FR Joint, réservoir d'huile ES Junta, Deposito de aceite PT Junta, reservatório oleo RU Уплотнение, масляного бачка 		000 466 1760	02.21674 





Application	Description	Details	Ref.	Erqo No.
NG/MK/SK	<ul style="list-style-type: none"> EN Cover, oil container DE Deckel, Ölbehälter FR Couvercle, carter d'huile ES Tapa, Deposito de aceite PT Tampa, reservatório óleo RU Крышка, масляного бачка 		000 466 0068	02.21675 
NG/MK/SK	<ul style="list-style-type: none"> EN Oil dipstick DE Ölmesstab FR Jauge de niveau d'huile ES Varilla de medición del aceite PT Vareta óleo RU Маслоизмерительный щуп 		000 466 0267	02.23238 
NG/MK/SK	<ul style="list-style-type: none"> EN Lock for oil container DE Verriegelung für Ölbehälter FR Verrou pour réservoir d'huile ES Mecanismo de bloqueo para deposito aceite PT Tampa pressão reservatório óleo para reservatório oleo RU Механизм блокировки для масляного бачка 		000 466 0740	02.21673 
NG/MK/SK (--Chassis)	<ul style="list-style-type: none"> EN Pressure line pump to steering DE Druckleitung Pumpe zur Lenkung FR Tuyau de direction pompe de direction ES Tubería de presión bomba aceite al dirección PT Flexível bomba direção hidráulica da bomba á caixa direção RU Нагнетательный трубопровод насоса к рулевому механизму 	L: 350 mm 	000 997 8152	02.22738 





THE ORIGINAL NUMBERS OF THE VEHICLE MANUFACTURER MAY BE USED FOR COMPARISON PURPOSES ONLY AND MUST NOT BE MENTIONED ON INVOICES TO VEHICLE OWNERS.

Application	Description	Details	Ref.	Erqo No.
BM 625, 652/653/ 654/655/656/658/659 (Chassis--)	<ul style="list-style-type: none"> EN Pressure line pump to steering DE Druckleitung Pumpe zur Lenkung FR Tuyau de direction pompe de direction ES Tubería de presión bomba aceite al dirección PT Flexível bomba direção hidráulica da bomba á caixa direcção RU Нагнетательный трубопровод насоса к рулевому механизму 	L: 280 mm	001 997 2752	02.22742 
				
NG/MK/SK	<ul style="list-style-type: none"> EN Pressure line pump to steering DE Druckleitung Pumpe zur Lenkung FR Tuyau de direction pompe de direction ES Tubo flexible bomba aceite al dirección PT Flexível bomba direção hidráulica da bomba á caixa direcção RU Нагнетательный трубопровод насоса к рулевому механизму 	L: 420 mm	000 997 8252	02.22739 
				

Drag LinkLenkstange • Barre de direction • Barra de dirección
Barra direção • Тяга рулевая

Application	Description	Details	Ref.	Erqo No.
BM 387/389/393/395	<ul style="list-style-type: none"> EN Drag link DE Lenkstange FR Barre de direction ES Barra de dirección PT Barra direção RU Рулевая тяга 	880 mm	387 460 4805	02.21553 
BM 387/389/391/393, 395	<ul style="list-style-type: none"> EN Drag link DE Lenkstange FR Barre de direction ES Barra de dirección PT Barra direção RU Рулевая тяга 	865 mm	387 460 4405	02.21551 
BM 387/389/391/393, 395, BM 620/621/623/624, 625/650/651/652	<ul style="list-style-type: none"> EN Drag link DE Lenkstange FR Barre de direction ES Barra de dirección PT Barra direção RU Рулевая тяга 	865 mm	387 460 3205	02.21549 
BM 387/389/395 BM 620/621/622/623, 625/645/646/647, 648/649/652/653, 654/655/656/657, 658/659	<ul style="list-style-type: none"> EN Drag link DE Lenkstange FR Barre de direction ES Barra de dirección PT Barra direção RU Продольная рулевая тяга 	885 mm	620 460 3705	02.21562 
BM 617/619/651/652, 653	<ul style="list-style-type: none"> EN Drag link DE Lenkstange FR Barre direction ES Barra de la dirección PT Barra direção RU Рулевая тяга 	860 mm	619 460 5205	02.21556 





Application	Description	Details	Ref.	Erqo No.
BM 617/619/651/652, 653	<ul style="list-style-type: none"> EN Drag link DE Lenkstange FR Barre direction ES Barra de la dirección PT Barra direccção RU Рулевая тяга 	860 mm	619 460 2905	02.21555 
BM 651/652/653	<ul style="list-style-type: none"> EN Drag link DE Lenkstange FR Barre direction ES Barra de la dirección PT Barra direccção RU Рулевая тяга 	840 mm	001 460 0405	02.21536 
BM 651/652/653	<ul style="list-style-type: none"> EN Drag link DE Lenkstange FR Barre direction ES Barra de la dirección PT Barra direccção RU Рулевая тяга 	840 mm	001 460 3005	02.21538 
BM 625/655/656/658	<ul style="list-style-type: none"> EN Drag link DE Lenkstange FR Barre direction ES Barra de la dirección PT Barra direccção RU Рулевая тяга 	870 mm	625 460 2505	02.21565 
BM 655/656/658/659	<ul style="list-style-type: none"> EN Drag link DE Lenkstange FR Barre direction ES Barra de la dirección PT Barra direccção RU Рулевая тяга 	900 mm	000 460 9905	02.21534 



Application	Description	Details	Ref.	Erqo No.
BM 381/383/385	<ul style="list-style-type: none"> EN Drag link DE Lenkstange FR Barre de direction ES Barra de dirección PT Barra direção RU Рулевая тяга 	890 mm	383 460 4405	02.21543 
BM 387 BM 620/621/622/623, 624/625/645/646, 647/648/649/652, 653/654/655/656, 657/658/659	<ul style="list-style-type: none"> EN Drag link right hand drive DE Lenkstange Rechtslenkung FR Barre de direction conduite à droite ES Barra de dirección volante a la derecha PT Barra direção direção lado direito RU Рулевая тяга Правостороннее управление 	885 mm	620 460 3905	02.21564 
BM 381/383	<ul style="list-style-type: none"> EN Ball joint, right hand thread DE Kugelgelenk, Rechtsgewinde FR Rotule, filetage à droite ES Rótula, rosca derecha PT Articulação alavanca, rosca direita RU Шаровая головка, Правая резьба 	C:22/TH:M30x1,5R/L:115	001 330 0435	02.21016 
BM 381/383/385/387, 389/393/395 BM 616/617/619	<ul style="list-style-type: none"> EN Ball joint, right hand thread DE Kugelgelenk, Rechtsgewinde FR Rotule, filetage à droite ES Rótula, rosca derecha PT Articulação alavanca, rosca direita RU Шаровая головка, Правая резьба 	C:26/TH:M30x1,5R/L:120	000 460 2648	02.21581 
V 730/731/733/739 BM 385/389/391/393, 397, BM 616/617/619/620, 621/622/623/624, 625/645/646/647, 648/649/652/653, 654/655/656/657, 658/659	<ul style="list-style-type: none"> EN Ball joint, right hand thread DE Kugelgelenk, Rechtsgewinde FR Rotule, filetage à droite ES Rótula, rosca derecha PT Articulação alavanca, rosca direita RU Шариковый шарнир, Правая резьба 	C:30/TH:M30x1,5R/L:120	000 460 2948	02.21586 

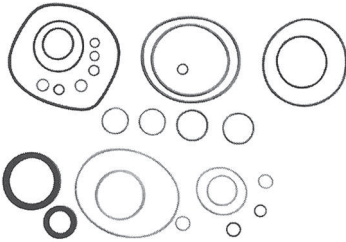

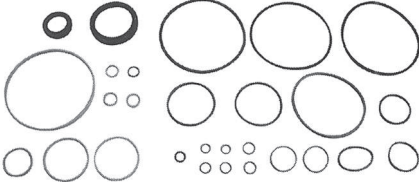

THE ORIGINAL NUMBERS OF THE VEHICLE MANUFACTURER MAY BE USED FOR COMPARISON PURPOSES ONLY AND MUST NOT BE MENTIONED ON INVOICES TO VEHICLE OWNERS.

Application	Description	Details	Ref.	Erqo No.
V 730/733/739 BM 385/391, BM 619/625/647/652, 654/657	<ul style="list-style-type: none"> EN Ball joint, left hand thread DE Kugelgelenk, Linksgewinde FR Rotule, filetage à gauche ES Rótula, rosca izquierda PT Articulação alavanca, rosca esquerda RU Шариковый шарнир, Левая резьба 	C:30/TH:M30x1,5L; L:120	000 460 3548	02.21590 
V 730/731/739 BM 625/651/652/653, 655	<ul style="list-style-type: none"> EN Ball joint, right hand thread DE Kugelkopf, Rechtsgewinde FR Rotule, filetage droit ES Rótula, rosca derecha PT Articulação alavanca, rosca direita RU Шаровая головка, Правая резьба 	C:32/TH:M30x1,5R/L:120	001 460 1748	02.21615 
V 731/739, BM 616/617/619/620, 621/622/623/624, 625/645/646/647, 648/649/652/653, 654/655/656/657, 658/659	<ul style="list-style-type: none"> EN Ball joint, right hand thread DE Kugelkopf, Rechtsgewinde FR Rotule, filetage droit ES Rótula, rosca derecha PT Articulação alavanca, rosca direita RU Шаровая головка, Правая резьба 	C:30/TH:M30x1,5R/L:120	001 460 7748	02.21623 
BM 625	<ul style="list-style-type: none"> EN Ball joint, right hand thread DE Kugelkopf, Rechtsgewinde FR Rotule, filetage droit ES Rótula, rosca derecha PT Articulação alavanca, rosca direita RU Шаровая головка, Правая резьба 	C:32/TH:M26x1,5R/L:75	001 460 1648	02.21614 
V 730/731/733/739, BM 385/389/391/393, 397 BM 617/619/620/621, 622/623,625/645, 646/647/648/649, 651/652/653/654, 655/656/657/658, 659	<ul style="list-style-type: none"> EN Boot DE Manschette FR Manchon ES Retén PT Guarda-pó terminal barra direção curta RU Манжета 	20 / 44 mm	000 330 1085	02.21028 





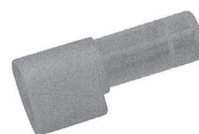
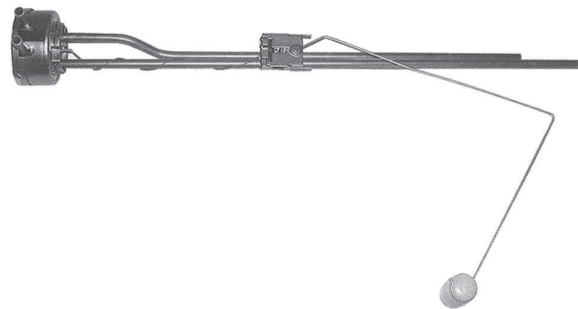
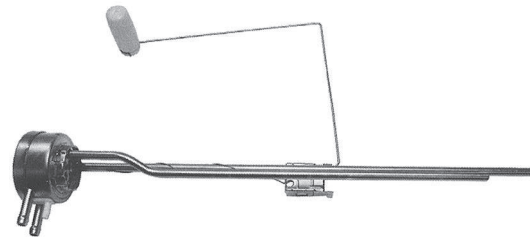
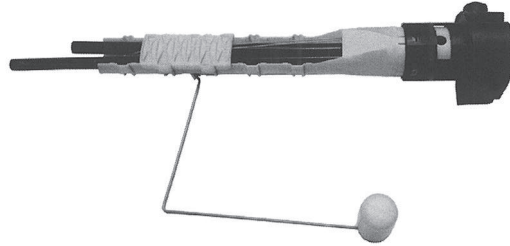

Application	Description	Details	Ref.	Erqo No.
BM 381/383/385/387, 389/393/395 BM 616/617	EN Boot DE Manschette FR Manchon ES Retén PT Guarda-pó terminal barra direção curta RU Манжета	23 / 50 mm	000 462 1896	02.23239 
V 730/731/733/739, BM 385/389/391/393, 397 BM 617/619/620/621, 622/623,625/645, 646/647/648/649, 651/652/653/654, 655/656/657/658, 659	EN Boot DE Manschette FR Manchon ES Retén PT Guarda-pó terminal barra direção curta RU Манжета	23 / 50 mm	000 462 1796	02.21656 

Application	Description	Details	Ref.	Erqo No.
L 765	<ul style="list-style-type: none"> EN Repair kit, steering pump DE Reparatursatz, Lenkumpumpe FR Kit de réparation, Pompe de direction ES Kit de reparación, Bomba de dirección PT Jogo reparo caixa direção RU Ремонтный комплект 		387 460 2601	02.21529 
L 765	<ul style="list-style-type: none"> EN Repair kit, steering pump DE Reparatursatz, Lenkumpumpe FR Kit de réparation, Pompe de direction ES Kit de reparación, Bomba de dirección PT Jogo reparo caixa direção RU Ремонтный комплект 		385 460 0501	02.21528 

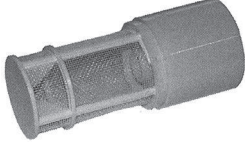



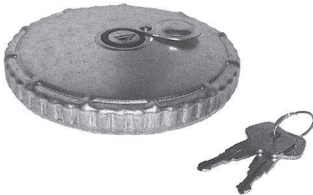

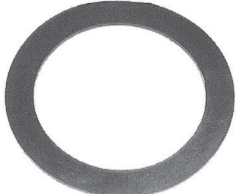



Application	Description	Details	Ref.	Erqo No.
BM 381/383/385/387, 389/393/395 BM 616/617/619/620, 621/622/623/624, 625/645/646/647, 648/649/652/653, 654/655/656/657, 658/659	(EN) Fuel level sensor (DE) Füllstandgeber (FR) Jauge à carburant (ES) Sensor de nivel (PT) Medidor nível combustível (RU) Датчик уровня	L: 460 mm	008 542 8017	02.21905 
BM 385 BM 620/621/622/623, 624/646/648/649, 655/656/658/659	(EN) Fuel gauge sender (DE) Füllstandgeber (FR) Jauge à carburant (ES) Sensor de nivel (PT) Medidor nível combustível (RU) Датчик уровня	L: 570 mm	011 542 6317	02.21912 
SK, VD0 221 824 054 011	(EN) Fuel gauge sender (DE) Füllstandgeber (FR) Jauge à carburant (ES) Sensor de nivel (PT) Medidor nível combustível (RU) Датчик уровня	L: 570 mm	011 542 6817	02.21913 





Application	Description	Details	Ref.	Erqo No.
BM 625/652/653/654, 655/656/657/658, 659	<ul style="list-style-type: none"> EN Fuel gauge with park heating connector / plastic fuel tank DE Füllstandgeber mit Standheizungsanschluss / Kunststofftank FR Jauge à carburant avec connexion pour chauffage sur parc / réservoir à gas-oil en plastique ES Sensor de nivel con conexión calefacción estacionamiento / deposito plástico PT Medidor nível combustível com aquecimento parque / deposito plástico RU Датчик уровня с соединителем стояночного подогрева / пластиковый топливный бак 	L: 450 mm	011 542 6117	02.21911 
BM 387/391	<ul style="list-style-type: none"> EN Fuel level sensor DE Füllstandgeber FR Jauge à carburant ES Sensor de nivel PT Medidor nível combustível RU Датчик уровня 	L: 545 mm	008 542 8117	02.21906 
BM 385/397, 620/621/623/624, 645/646/648/649, 652/653/655/656, 657/658/659	<ul style="list-style-type: none"> EN Fuel level sensor DE Füllstandgeber FR Jauge à carburant ES Sensor de nivel PT Medidor nível combustível RU Датчик уровня 	580 mm	008 542 8317	02.21907 
NG/MK/SK --Id-No. K169122	<ul style="list-style-type: none"> EN Fuel strainer DE Kraftstoffsieb FR Filtre tamis ES Tamiz de combustible PT Peneira medidor combustível RU Топливный сетчатый фильтр 		000 471 0235	02.21681 









Application	Description	Details	Ref.	Erqo No.
SK Id-No. K169123--	<ul style="list-style-type: none"> EN Fuel strainer for fuel gauge senders DE Kraftstoffsieb für Tankgeber FR Filtre carburant pour jauge à gas-oil ES Tamiz de combustible para sensor deposito PT Filtro combustível para bóia nível combustível RU Топливный сетчатый фильтр для датчика уровня топлива 		000 471 0935	02.21682 
				
BM 381/383/385/387, 389/393/395 BM 616/617/619/620, 621/622/623/624, 625/645/646/647, 648/649/652/653, 654/655/656/657, 658/659	<ul style="list-style-type: none"> EN Filler cap, not vented not lockable DE Tankdeckel, unbelüftet nicht abschließbar FR Bouchon de réservoir, non ventilé non verrouillable ES Tapón del depósito, no ventilado sin cierre PT Tampa, tanque combustível, no ventilado sem chave RU Крышка топливного бака, невентилируемая незапираемая 	Ø 80 mm	000 470 0305	02.21677 
				
BM 625/652/653/654, 655/656/657/658, 659	<ul style="list-style-type: none"> EN Tank cover, not vented DE Tankdeckel, unbelüftet FR Bouchon de réservoir, non ventilé ES Tapón del depósito, no ventilado PT Tampa tanque, no ventilado não ventilada RU Крышка топливного бака, невентилируемая 	80 mm	000 471 6730	02.21679 
				
BM 381/383/385/387, 389/393/395 BM 616/617/619/620, 621/622/623/624, 625/645/646/647, 648/649/652/653, 654/655/656/657, 658/659	<ul style="list-style-type: none"> EN Seal ring DE Dichtring FR Bague d'étanchéité ES Retén PT Anel vedação tampa tanque RU Уплотнительное кольцо 		304 997 0340	02.22619 
				



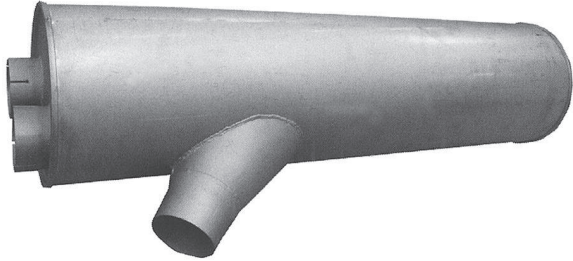

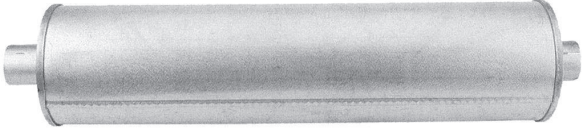

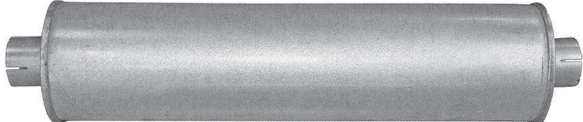
THE ORIGINAL NUMBERS OF THE VEHICLE MANUFACTURER MAY BE USED FOR COMPARISON PURPOSES ONLY AND MUST NOT BE MENTIONED ON INVOICES TO VEHICLE OWNERS.



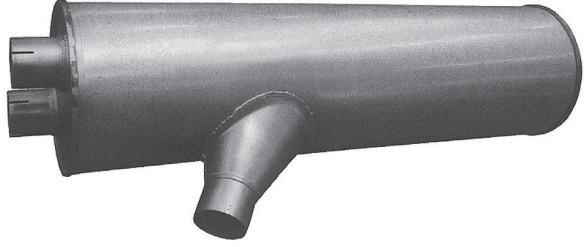

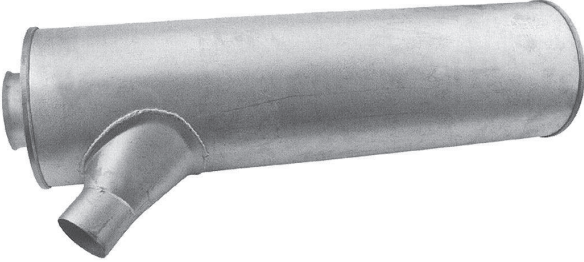

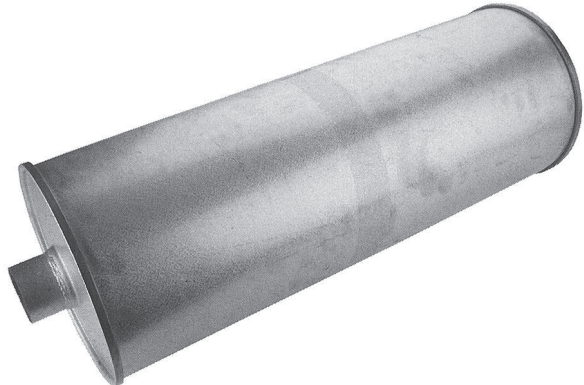

Application	Description	Details	Ref.	Erqo No.
BM 381/383/385/387, 389/391/393/395, 615/616/617/619, 620/621/622/623, 624/625/645/646, 647/648/649/652, 653/654/655/656, 657/658/659	<ul style="list-style-type: none"> EN Rubber pad, roll length = 50 m DE Gummiunterlage, Rollenlänge = 50 m FR Caoutchouc de sangle de réservoir, longueur du rouleau = 50 m ES Separador de goma, Largo = 50 m PT Protetor cinta tanque combustível, rolo com 50 m RU Резиновая подкладка, длина мотка = 50 м 	47 mm 	363 475 0320	02.21685 
BM 381/383/385/387, 389/391/393/395, 615/616/617/619, 620/621/622/623, 624/625/645/646, 647/648/649/652, 653/654/655/656, 657/658/659	<ul style="list-style-type: none"> EN Rubber pad, roll length = 50 m DE Gummiunterlage, Rollenlänge = 50 m FR Sangle caoutchouc réservoir, rouleau = 50 m ES Separador de goma, Largo = 50 m PT Protetor cinta tanque combustível, rolo com 50 m RU Резиновая подкладка, Длина мотка 50 м 	62 mm 	363 475 0220	02.21684 
BM 381/383/385/387, 389/391/393/395, 615/616/617/619, 620/621/622/623, 624/625/645/646, 647/648/649/652, 653/654/655/656, 657/658/659	<ul style="list-style-type: none"> EN Rubber pad, roll length = 50 m DE Gummiunterlage, Rollenlänge = 50 m FR Sangle caoutchouc réservoir, rouleau = 50 m ES Separador de goma, Largo = 50 m PT Protetor cinta tanque combustível, rolo com 50 m RU Резиновая подкладка, Длина мотка 50 м 	109 mm 	363 475 0120	02.21683 
9 NG/MK/SK	<ul style="list-style-type: none"> EN Fuel line DE Kraftstoffleitung FR Flexible carburant ES Tubería de combustible PT Tubo combustível RU Топливопровод 	11 x 1,5 mm / 3500 mm 		02.23240 
NG/MK/SK	<ul style="list-style-type: none"> EN Fuel line DE Kraftstoffleitung FR Flexible carburant ES Tubería de combustible PT Tubo combustível RU Топливопровод 	11 x 1,5 mm / 3500 mm 		02.23241 

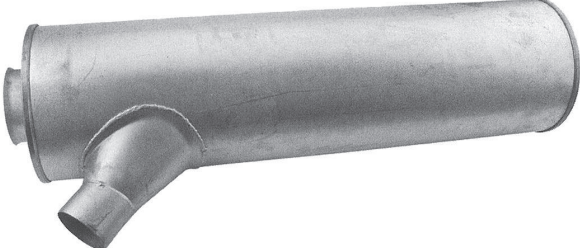

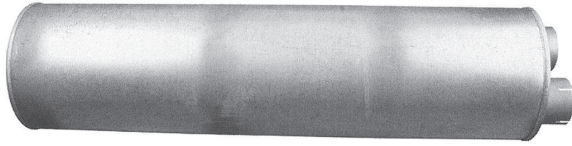

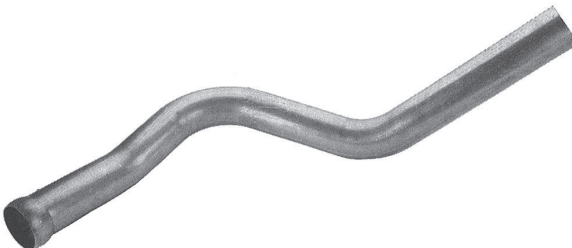

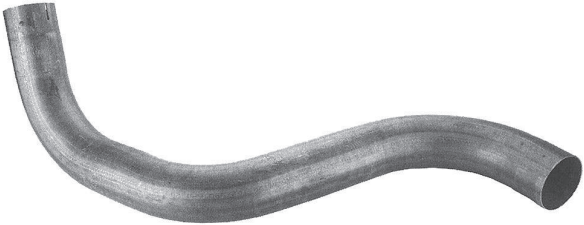

Application	Description	Details	Ref.	Erqo No.
NG/MK/SK	<ul style="list-style-type: none"> EN Fuel line DE Kraftstoffleitung FR Flexible carburant ES Tubería de combustible PT Tubo combustível RU Топливопровод 	6 x 1 mm / 3500 mm		02.23242 
NG/MK/SK	<ul style="list-style-type: none"> EN Fuel line DE Kraftstoffleitung FR Flexible carburant ES Tubería de combustible PT Tubo combustível RU Топливопровод 	11 x 1,5 mm / 4200 mm		02.23243 
NG/MK/SK	<ul style="list-style-type: none"> EN Fuel line DE Kraftstoffleitung FR Flexible carburant ES Tubería de combustible PT Tubo combustível RU Топливопровод 	11 x 1,5 mm / 3650 mm		02.23244 
NG/MK/SK	<ul style="list-style-type: none"> EN Hose DE Kraftstoffschlauch FR Durite ES Manguito de combustible PT Mangueira RU Топливный шланг 	9 x 2,5 mm, in roll lengths of 25 m	305 476 0126	02.21687 

THE ORIGINAL NUMBERS OF THE VEHICLE MANUFACTURER MAY BE USED FOR COMPARISON PURPOSES ONLY AND MUST NOT BE MENTIONED ON INVOICES TO VEHICLE OWNERS.

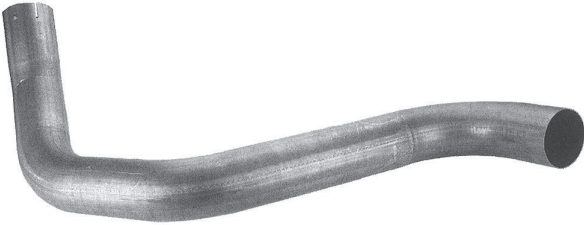

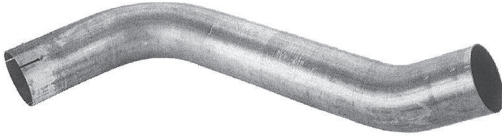





Application	Description	Details	Ref.	Erqo No.
BM 625, 655/656/658/659	<ul style="list-style-type: none"> EN Silencer left DE Schalldämpfer links FR Silencieux gauche ES Silencioso izquierda PT Silencioso esquerdo RU Глушитель левая 		645 490 2001	02.21704 
BM 616/617/619, 652/655/659	<ul style="list-style-type: none"> EN Silencer DE Schalldämpfer FR Silencieux ES Silenciador PT Silencioso RU Глушитель 		645 490 1501	02.21703 
10 BM 381/383/385 BM 616/617/619	<ul style="list-style-type: none"> EN Silencer DE Schalldämpfer FR Silencieux ES Silenciador PT Silencioso RU Глушитель 		383 490 0201	02.21696 

Application	Description	Details	Ref.	Erqo No.
BM 387/389/393/395	<ul style="list-style-type: none"> EN Silencer DE Schalldämpfer FR Silencieux ES Silencioso PT Silencioso RU Глушитель 		387 490 0501	02.21697 
BM 619/620/621/623, 624 -- chassis	<ul style="list-style-type: none"> EN Silencer DE Schalldämpfer FR Silencieux ES Silenciador PT Silencioso RU Глушитель 		620 490 0601	02.21700 
BM 619/620/621/623, 624	<ul style="list-style-type: none"> EN Silencer left DE Schalldämpfer links FR Silencieux gauche ES Silencioso izquierda PT Silencioso esquerdo RU Глушитель левая 		620 490 0001	02.21699 

Application	Description	Details	Ref.	Erqo No.
BM 645/646/648/649	<ul style="list-style-type: none"> EN Silencer DE Schalldämpfer FR Silencieux ES Silenciador PT Silencioso RU Глушитель 		645 490 0201	02.21701 
BM 652/653/654/655, 656/659	<ul style="list-style-type: none"> EN Silencer DE Schalldämpfer FR Silencieux ES Silenciador PT Silencioso RU Глушитель 		652 490 0101	02.21705 
BM 387/389/393/395, 620/621/623/624	<ul style="list-style-type: none"> EN Exhaust pipe front - right DE Auspuffrohr vorne - rechts FR Tuyau d'échappement avant - droit ES Tubo de escape delantero - derecho PT Tubo escape frente - direito RU Выхлопная труба передняя - правая 		389 490 1319	02.21706 
BM 645/646/648/649	<ul style="list-style-type: none"> EN Exhaust pipe, front DE Auspuffrohr, vorne FR Tuyau d'échappement, avant ES Tubo de escape, delantero PT Tubo escape, frente RU Выхлопная труба, передняя 		645 490 0219	02.21707 

Application	Description	Details	Ref.	Erqo No.
BM 655/656/658/659 -- chassis 5439561	<p>EN Exhaust pipe front - left</p> <p>DE Auspuffrohr vorne - links</p> <p>FR Tuyau d'échappement avant - gauche</p> <p>ES Tubo de escape delantero - izquierdo</p> <p>PT Tubo escape frente - esquerdo</p> <p>RU Выхлопная труба передняя - левая</p>		655 490 0919	02.21708 
BM 655/656/658/659 chassis 5439562 --	<p>EN Exhaust pipe front - left</p> <p>DE Auspuffrohr vorne - links</p> <p>FR Tuyau d'échappement avant - gauche</p> <p>ES Tubo de escape delantero - izquierdo</p> <p>PT Tubo escape frente - esquerdo</p> <p>RU Выхлопная труба передняя - левая</p>		655 490 4419	02.21710 
BM 655/656/658/659 -- chassis 5439561	<p>EN Exhaust pipe front - right</p> <p>DE Auspuffrohr vorne - rechts</p> <p>FR Tuyau d'échappement avant - droit</p> <p>ES Tubo de escape delantero - derecho</p> <p>PT Tubo escape frente - direito</p> <p>RU Выхлопная труба передняя - правая</p>		655 490 1019	02.21709 
BM 655/656/658/659 chassis 5439562 --	<p>EN Exhaust pipe front - right</p> <p>DE Auspuffrohr vorne - rechts</p> <p>FR Tuyau d'échappement avant - droit</p> <p>ES Tubo de escape delantero - derecho</p> <p>PT Tubo escape frente - direito</p> <p>RU Выхлопная труба передняя - правая</p>		655 490 4519	02.21711 

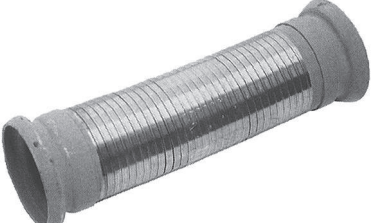
THE ORIGINAL NUMBERS OF THE VEHICLE MANUFACTURER MAY BE USED FOR COMPARISON PURPOSES ONLY AND MUST NOT BE MENTIONED ON INVOICES TO VEHICLE OWNERS.

Application	Description	Details	Ref.	Erqo No.
BM 645/646/648/649	<ul style="list-style-type: none"> EN Exhaust pipe rear - left DE Auspuffrohr hinten - links FR Tuyau d'échappement arrière - gauche ES Tubo de escape trasero - izquierdo PT Tubo escape traseiro - esquerdo RU Выпускная труба заднее - левый 		645 492 0404	02.21717 
BM 655/656/658/659 -- chassis 5439561	<ul style="list-style-type: none"> EN Exhaust pipe rear - left DE Auspuffrohr hinten - links FR Tuyau d'échappement arrière - gauche ES Tubo de escape trasero - izquierdo PT Tubo escape traseiro - esquerdo RU Выпускная труба заднее - левый 		655 490 1521	02.21712 
BM 655/656/658/659 chassis 5439562 -- 5756872	<ul style="list-style-type: none"> EN Exhaust pipe rear - left DE Auspuffrohr hinten - links FR Tuyau d'échappement arrière - gauche ES Tubo de escape trasero - izquierdo PT Tubo escape traseiro - esquerdo RU Выхлопная труба заднее - левый 		655 492 0614	02.21724 
BM 615/616/617/619, 620/621/622/623, 624/625/652/653, 654/656	<ul style="list-style-type: none"> EN Flexible pipe, 80 mm / stainless steel DE Flexibles Rohr, 80 mm / Edelstahl FR Tube flexible, 80 mm / acier inox ES Latiguillo, 80 mm / acero inoxidable PT Tubo flexível, 80 mm / aço inoxidável RU Гибкая труба, 80 мм / Нержавеющая ст. 		620 490 0365	02.21713 

Application	Description	Details	Ref.	Erqo No.
BM 615/616/617/619, 620/621/622/623, 624/625/652/653, 654/655/656/657, 658/659	<ul style="list-style-type: none"> EN Flexible pipe, 95 mm / stainless steel DE Flexibles Rohr, 95 mm / Edelstahl FR Tube flexible, 95 mm / acier inox ES Latiguillo, 95 mm / acero inoxidable PT Tubo flexível, 95 mm / aço inoxidável RU Гибкая труба, 95 мм / Нержавеющая сталь 		620 490 0465	02.21714 
				
BM 625/645/646/647, 648/649/652/653, 654/656/657/658, 659	<ul style="list-style-type: none"> EN Flexible pipe, 105 mm / stainless steel DE Flexibles Rohr, 105 mm / Edelstahl FR Tube flexible, 105 mm / acier inox ES Latiguillo, 105 mm / acero inoxidable PT Tubo flexível, 105 mm / aço inoxidável RU Гибкая труба, 105 мм / Нержавеющая сталь 		621 490 0065	02.21715 
				
BM 387/389/391/393, 395	<ul style="list-style-type: none"> EN Connecting pipe DE Muffe FR Manchon ES Manguito PT Tubo conexão RU Муфта 		387 492 1209	02.21723 
BM 620/621/622/623, 624 -- chassis				
				
BM 615/616/617/619, 620/621/622/623, 624/652/653	<ul style="list-style-type: none"> EN Connecting pipe old version DE Muffe alte Ausführung FR Manchon ancienne version ES Manguito version antigua PT Luva junção escapamento versão antiga RU Муфта старая версия 	Ø 65,0 mm	652 492 0008	02.21722 
				







THE ORIGINAL NUMBERS OF THE VEHICLE MANUFACTURER MAY BE USED FOR COMPARISON PURPOSES ONLY AND MUST NOT BE MENTIONED ON INVOICES TO VEHICLE OWNERS.



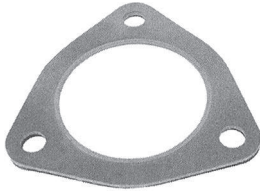

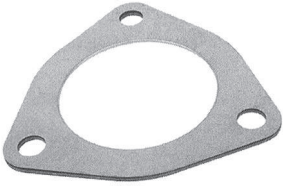

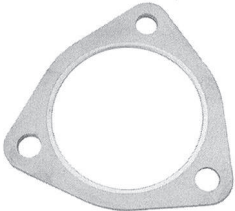

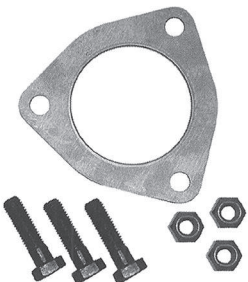
Application	Description	Details	Ref.	Erqo No.
BM 615/616/617/619, 620/621/622/623, 624/625/652/653, 654/656	<ul style="list-style-type: none"> EN Connecting pipe new version DE Muffe neue Ausführung FR Manchon nouvelle version ES Manguito nueva versión PT Luva junção escapamento versão nova RU Муфта новая версия 	Ø 67,5 mm	617 492 0008	02.21718 
				
BM 615/616/617/619, 620/621/622/623, 624/625/652/653, 654/655/656/657, 658/659	<ul style="list-style-type: none"> EN Connecting pipe DE Muffe FR Manchon ES Manguito PT Luva junção escapamento RU Муфта 	Ø 82,5 mm	620 492 0208	02.21720 
				
10 BM 625/645/646/647, 648/649/652/653, 654/656/657/658, 659	<ul style="list-style-type: none"> EN Connecting pipe DE Muffe FR Manchon ES Manguito PT Luva junção escapamento RU Муфта 	Ø 92,5 mm	621 492 0008	02.21721 
				

Application	Description	Details	Ref.	Erqo No.
BM 615/616/617/619, 620/621/622/623, 624/625/652/653, 654/656	<ul style="list-style-type: none"> EN Clamp DE Schelle FR Bride ES Abrazadera PT Abraçadeira RU Хомут 		620 997 0490	02.22775 
BM 615/616/617/619, 620/621/622/623, 624/625/652/653, 654/655/656/657, 658/659	<ul style="list-style-type: none"> EN Clamp DE Schelle FR Bride ES Abrazadera PT Abraçadeira RU Хомут 		620 997 0590	02.22776 
BM 625/645/646/647, 648/649/652/653, 654/656/657/658, 659	<ul style="list-style-type: none"> EN Clamp DE Schelle FR Bride ES Abrazadera PT Abraçadeira RU Хомут 		621 997 0090	02.22777 
BM 615/616/617/619, 620/621/622/623, 624/625/652/653, 654/656	<ul style="list-style-type: none"> EN Clamp DE Schelle FR Bride ES Abrazadera PT Abraçadeira RU Хомут 		620 492 0840	02.21725 

Application	Description	Details	Ref.	Erqo No.
BM 615/616/617/619, 620/621/622/623, 624/625/652/653, 654/655/656/657, 658/659	<ul style="list-style-type: none"> EN Clamp DE Schelle FR Bride ES Abrazadera PT Abraçadeira RU Хомут 		620 492 0940	02.21726 
BM 625/645/646/647, 648/649/652/653, 654/656/657/658, 659	<ul style="list-style-type: none"> EN Clamp DE Schelle FR Bride ES Abrazadera PT Abraçadeira RU Хомут 		625 492 0040	02.21727 
BM 617/620/621/622, 623/624	<ul style="list-style-type: none"> EN Seal ring DE Dichtring FR Bague d'étanchéité ES Retén PT Anel camisa RU Уплотнительное кольцо 		000 142 3957	02.20035 
BM 381/383/385/387, 389/391/393/395, 615/616/617/619, 620/621/622/623, 624/625/645/646, 647/648/649/652, 653/654/655/656, 657/658/659	<ul style="list-style-type: none"> EN Clamp DE Schelle FR Bride ES Abrazadera PT Abraçadeira RU Хомут 	75,5 mm 	071555 075502	02.22889 



Application	Description	Details	Ref.	Erqo No.
BM 381/383/385/387, 389/391/393/395, 615/616/617/619, 620/621/622/623, 624/625/645/646, 647/648/649/652, 653/654/655/656, 657/658/659	EN Clamp DE Schelle FR Bride ES Abrazadera PT Abraçadeira RU Хомут	78,5 mm	071555 078502	02.22890 
BM 381/383/385/387, 389/391/393/395, 615/616/617/619, 620/621/622/623, 624/625/645/646, 647/648/649/652, 653/654/655/656, 657/658/659	EN Clamp DE Schelle FR Bride ES Abrazadera PT Abraçadeira RU Хомут	90,5 mm	071555 090502	02.22892 
BM 381/383/385/387, 389/391/393/395, 615/616/617/619, 620/621/622/623, 624/625/645/646, 647/648/649/652, 653/654/655/656, 657/658/659	EN Clamp DE Schelle FR Bride ES Abrazadera PT Abraçadeira RU Хомут	94,5 mm	071555 094502	02.22893 
BM 381/383/385/387, 389/391/393/395, 615/616/617/619, 620/621/622/623, 624/625/645/646, 647/648/649/652, 653/654/655/656, 657/658/659	EN Clamp DE Schelle FR Bride ES Abrazadera PT Abraçadeira RU Хомут	120,5 mm	071555 120502	02.22894 

Application	Description	Details	Ref.	Erqo No.
NG	<ul style="list-style-type: none"> EN Flange gasket, exhaust pipe material: copper DE Flanschdichtung, Abgasrohr Material: Kupfer FR Joint palier, tuyau d'échappement matériau: cuivre ES Junta de brida, Multiple de escape material: cobre PT Junta flange escapamento material: cobre RU Фланцевое уплотнение, Выхлопная труба материал: медь 	Ø 78 mm	302 490 0080	02.21716 
				
NG	<ul style="list-style-type: none"> EN Flange gasket, exhaust pipe material: steel DE Flanschdichtung, Abgasrohr Material: Stahl FR Joint palier, tuyau d'échappement matériau: acier ES Junta de brida, Multiple de escape material: acero PT Junta flange escapamento material: aço RU Фланцевое уплотнение, Выхлопная труба материал: сталь 	Ø 78 mm		02.21716 
				
NG/MK/SK	<ul style="list-style-type: none"> EN Flange gasket, exhaust pipe DE Flanschdichtung, Abgasrohr FR Joint palier, tuyau d'échappement ES Junta de brida, Multiple de escape PT Junta flange escapamento RU Фланцевое уплотнение, Выхлопная труба 		442 492 0080	02.21728 
				
NG	<ul style="list-style-type: none"> EN Mounting kit, exhaust pipe DE Befestigungssatz, Abgasrohr FR Kit de montage, tuyau d'échappement ES Juego de fijación, Tubo de escape PT Jogo reparo escapamento RU Ремонтный комплект, Выхлопная труба 	M 12 x 45		02.23245 
				

Application	Description	Details	Ref.	Erqo No.
NG/MK/SK	<ul style="list-style-type: none"> EN Repair kit DE Reparatursatz FR Kit de réparation ES Kit de reparación PT Jogo reparo RU Ремонтный комплект 	M 12 x 45		02.23246
				
				
NG/MK/SK	<ul style="list-style-type: none"> EN Repair kit DE Reparatursatz FR Kit de réparation ES Kit de reparación PT Jogo reparo RU Ремонтный комплект 	M 12 x 50		02.23247
				
				
NG/MK/SK	<ul style="list-style-type: none"> EN Rubber bearing DE Gummilager FR Silentbloc ES Cojinete de goma PT Coxim, amortecedor RU Саленблок 	M 10 x 1,5	001 987 5340	02.22406
				
				
NG/MK/SK	<ul style="list-style-type: none"> EN Buffer DE Dämpfer FR Silentbloc ES Amortiguador PT Coxim RU Демпфер 		381 492 0082	02.21729
				
				

Radiator & Expansion Tank

Kühler & Ausdehnungsgefäß • Radiateur & Vase d'Expansion • Radiador & Vaso de Expansión
 Radiador & Vaso de Expansão • Радиатор и расширительный бачок

Application	Description	Details	Ref.	Erqo No.
BM 655/656/657/658	<ul style="list-style-type: none"> EN Radiator DE Kühler FR Radiateur ES Radiador PT Radiador RU Радиатор 	801 x 864 x 47 mm	656 500 1603	02.21732 
BM 625, 650/655/656/657, 658/659	<ul style="list-style-type: none"> EN Radiator DE Kühler FR Radiateur ES Radiador PT Radiador RU Радиатор 	638 x 730 x 42 mm	652 501 6501	02.21743 
BM 625, 651/652/653/654, 655/656/657/658, 659 --Id-No. K037736	<ul style="list-style-type: none"> EN Radiator DE Kühler FR Radiateur ES Radiador PT Radiador RU Радиатор 	638 x 810 x 42 mm	652 501 6601	02.21744 

Radiator & Expansion TankKühler & Ausdehnungsgefäß • Radiateur & Vase d'Expansion • Radiador & Vaso de Expansión
Radiador & Vaso de Expansão • Радиатор и расширительный бачок

Application	Description	Details	Ref.	Erqo No.
BM 625, 652/653/654/655, 656/657/658/659 Id-No. K037737--	EN Radiator DE Kühler FR Radiateur ES Radiador PT Radiador RU Радиатор	638 x 850 x 42 mm	652 501 6901	02.21746 

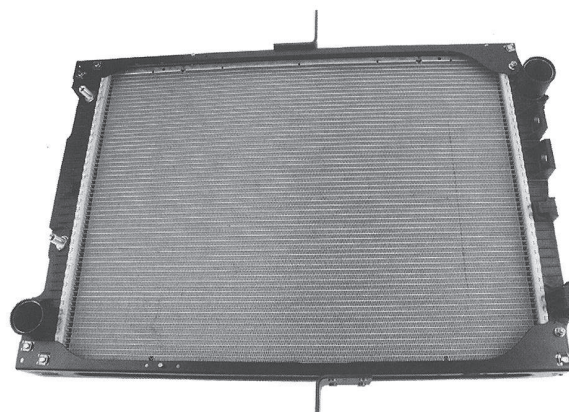

BM 650/651/652/653, 654 MK	EN Radiator DE Kühler FR Radiateur ES Radiador PT Radiador RU Радиатор	606 x 632 mm	650 501 1201	02.21740 
---	---	--------------	--------------	--

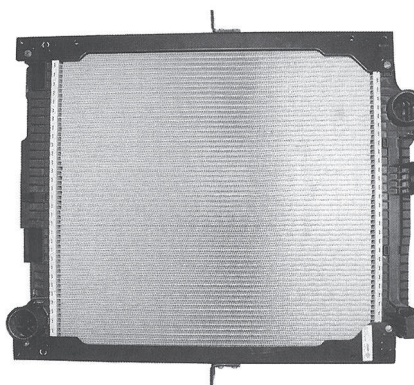

BM 652.146 (1726 K)	EN Radiator DE Kühler FR Radiateur ES Radiador PT Radiador RU Радиатор	606 x 632 x 60 mm	652 501 6301	02.21742 
------------------------	---	-------------------	--------------	---

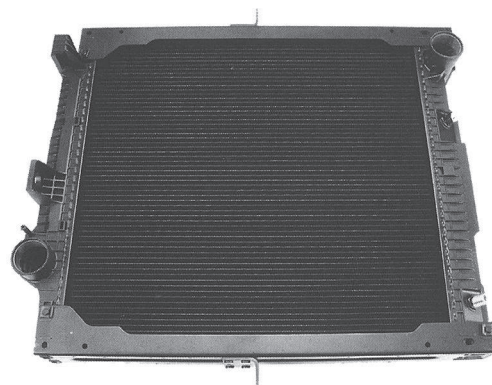

Application	Description	Details	Ref.	Erqo No.
BM 625, 655/656/657/658, 659	<ul style="list-style-type: none"> EN Radiator DE Kühler FR Radiateur ES Radiador PT Radiador RU Радиатор 	790 x 823 x 46 mm	655 500 3003	02.21731 
				
NG/MK/SK	<ul style="list-style-type: none"> EN Rubber mounting old version DE Gummilager alte Ausführung FR Silentbloc ancienne version ES Cojinete de goma versión antigua PT Coxim versão antiga RU Резиновая подушка старое исполнение 		387 504 0012	02.21817 
				
NG/MK/SK	<ul style="list-style-type: none"> EN Rubber bearing new version DE Gummilager neue Ausführung FR Silentbloc nouvelle version ES Cojinete de goma nueva versión PT Coxim nova versão RU Резиновая подушка нового типа 		620 504 0112	02.21819 
				
BM 625, 652/653/654/655, 656/657/658/659	<ul style="list-style-type: none"> EN Washer DE Scheibe FR Rondelle ES Arandela PT Anel RU Шайба 	40 x 40 mm	656 990 0144	02.22470 
				

Application	Description	Details	Ref.	Erqo No.
BM 381/383/385/387, BM 616/617/619/621	<ul style="list-style-type: none"> EN Rubber mounting DE Gummilager FR Silentbloc ES Cojinete de goma PT Coxim RU Резиновая подушка 		387 504 0112	02.21818 

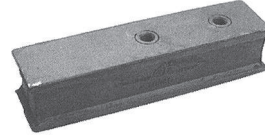

BM 381/383/385/387, 389/393/395	<ul style="list-style-type: none"> EN Washer DE Scheibe FR Rondelle ES Arandela PT Anel RU Шайба 		652 504 0038	02.21820 
BM 616/617/619/620, 621/622/623/624, 625/645/646/647, 648/649/652/653, 654/655/656/657, 658/659				







BM 387/389/391/393, 395,	<ul style="list-style-type: none"> EN Rubber ring, for fan DE Gummiring, für Lüfter FR Anneau de caoutchouc, pour ventilateur ES Aro de goma, para el ventilador PT Anel protetor ventilator radiador RU Резиновое кольцо, для вентилятора 	Ø 630 mm	363 505 0180	02.21826 
615/616/617/619,				
BM 620/621/622/623, 624/625 -- chassis				



BM 620/621/622/623, 624/625/645/646, 647/648/649	<ul style="list-style-type: none"> EN Rubber ring, for fan DE Gummiring, für Lüfter FR Anneau de caoutchouc, pour ventilateur ES Aro de goma, para el ventilador PT Anel protetor ventilator radiador RU Резиновое кольцо, для вентилятора 	Ø 682 mm	620 505 0086	02.21828 
BM 625/652/653/654, 655/656/657/658, 659 -- chassis K037736, -- chassis Z902908				



Application	Description	Details	Ref.	Erqo No.
BM 625/652/653/654, 655/656/657/658, 659 chassis K037737 --	<ul style="list-style-type: none"> EN Rubber ring, for fan DE Gummiring, für Lüfter FR Anneau de caoutchouc, pour ventilateur ES Aro de goma, para el ventilador PT Anel protetor ventilator radiador RU Резиновое кольцо, для вентилятора 	Ø 707 mm	656 505 0286	02.21830 
BM 615/616/617/619, 621 -- chassis	<ul style="list-style-type: none"> EN Rubber ring, for fan DE Gummiring, für Lüfter FR Anneau de caoutchouc, pour ventilateur ES Aro de goma, para el ventilador PT Anel protetor Ventilator radiador RU Резиновое кольцо, для вентилятора 	Ø 616 mm	617 505 0086	02.21827 
625.036, 625.037, 625.196, 625.197 chassis Z902909 --	<ul style="list-style-type: none"> EN Rubber ring, for fan DE Gummiring, für Lüfter FR Anneau de caoutchouc, pour ventilateur ES Aro de goma, para el ventilador PT Anel protetor ventilator radiador RU Резиновое кольцо, для вентилятора 	Ø 679 mm	656 505 0186	02.21829 
BM 387/389/391/393, 395, 615/616/617/619 BM 620/621/622/623, 624/625 -- chassis	<ul style="list-style-type: none"> EN Clamp DE Schelle FR Bride ES Abrazadera PT Abraçadeira RU Хомут 	630 - 665 mm	363 995 0065	02.23248 



Application	Description	Details	Ref.	Erqo No.
BM 620/621/622/623, 624/625	<ul style="list-style-type: none"> EN Fan cover DE Lüfterhaube FR Carter de ventilateur ES Carcasa del ventilador PT Defletor radiador RU Кожух вентилятора 		620 505 0655	02.21822
BM 655/656/657/658, 659 -- chassis 5923089				



BM 620/621/622/623, 624/625/645/646, 648/649	<ul style="list-style-type: none"> EN Fan cover DE Lüfterhaube FR Carter de ventilateur ES Carcasa del ventilador PT Defletor radiador RU Кожух вентилятора 		620 505 0855	02.21823
BM 655/656/657/658, 659 -- chassis K037736				

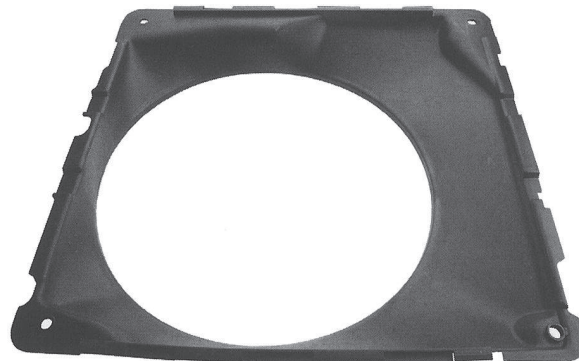

BM 655/656/657/658, 659 chassis K037737 --	<ul style="list-style-type: none"> EN Fan cover DE Lüfterhaube FR Carter de ventilateur ES Carcasa del ventilador PT Defletor radiador RU Кожух вентилятора 		656 505 0255	02.21825
				

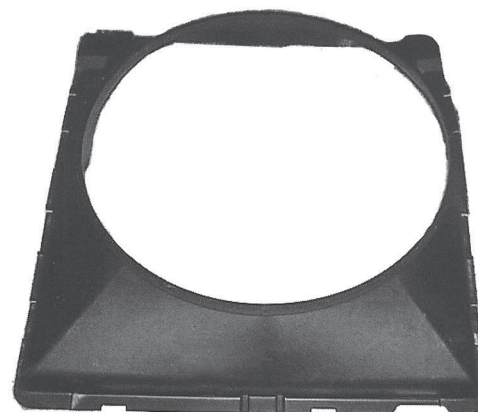

Radiator & Expansion Tank











Kühler & Ausdehnungsgefäß • Radiateur & Vase d'Expansion • Radiador & Vaso de Expansión
 Radiador & Vaso de Expansão • Радиатор и расширительный бачок

Application	Description	Details	Ref.	Erqo No.
BM 625/652/653/654, 655/656/657/658, 659 chassis K037737 --	EN Fan cover DE Lüfterhaube FR Carter de ventilateur ES Carcasa del ventilador PT Defletor radiador RU Кожух вентилятора		656 505 0055	02.21824 
BM 620/621/622/623, 624/625/645/646, 647/648/649 BM 655/656/657/658, 659 chassis 5923090 --	EN Fan cover DE Lüfterhaube FR Carter de ventilateur ES Carcasa del ventilador PT Defletor radiador RU Кожух вентилятора		620 505 0355	02.21821 
BM 625/652/653/654, 655/656/657/658, 659	EN Expansion tank DE Ausdehnungsgefäß FR Vase d'expansion ES Vaso de expansión PT Tanque expansão RU Расширительный бачок		000 500 2249	02.21736 



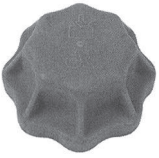

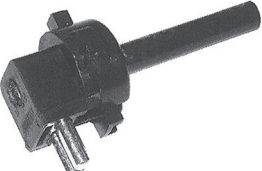

Radiator & Expansion Tank









Kühler & Ausdehnungsgefäß • Radiateur & Vase d'Expansion • Radiador & Vaso de Expansión
Radiador & Vaso de Expansão • Радиатор и расширительный бачок

Application	Description	Details	Ref.	Erqo No.
BM 625/652/653/654, 655/656/657/658, 659	<ul style="list-style-type: none"> EN Expansion tank DE Ausdehnungsgefäß FR Vase d'expansion ES Vaso de expansión PT Tanque expansão RU Расширительный бачок 		000 500 2149	02.21735 
BM 620/621/622/623, 624/625/645/646, 647/648/649	<ul style="list-style-type: none"> EN Expansion tank DE Ausdehnungsgefäß FR Vase d'expansion ES Vaso de expansión PT Tanque expansão RU Расширительный бачок 		000 500 0749	02.21733 
BM 615/616/617/619, 620/621/622/623, 624/645/646/647, 648/649	<ul style="list-style-type: none"> EN Expansion tank DE Ausdehnungsgefäß FR Vase d'expansion ES Vaso de expansión PT Tanque expansão RU Расширительный бачок 		620 500 0149	02.21738 
BM 381/383/385/387, 389/395	<ul style="list-style-type: none"> EN Expansion tank DE Ausdehnungsgefäß FR Vase d'expansion ES Depósito de expansión PT Tanque expansão RU Расширительный бачок 		381 500 0849	02.21737 









Application	Description	Details	Ref.	Erqo No.
BM 381/383/385/387, 389/393/395 BM 616/617/619/620, 621/622/623/624, 625/645/646/647, 648/649/652/653, 654/655/656/657, 658/659	<ul style="list-style-type: none"> EN Radiator cap DE Kühlerdeckel FR Bouchon de radiateur ES Tapa del radiador PT Tampa radiador RU Крышка радиатора 		000 501 4515	02.21753 
BM 616/617/619/620, 621/622/623/624, 625/645/646/647, 648/649/651/652, 653/654/655/656, 657/658/659	<ul style="list-style-type: none"> EN Radiator cap, with chain DE Kühlerdeckel, mit Kette FR Bouchon de radiateur, avec chaîne ES Tapa del radiador, con cadena PT Tampa radiador, com corrente RU Крышка радиатора, с цепью 	0,7 bar 	000 501 5315	02.21755 
BM 381/383/385/387, 389/393/395 BM 616/617/619/620, 621/622/623/624, 645/646/647	<ul style="list-style-type: none"> EN Radiator cap, with chain DE Kühlerdeckel, mit Kette FR Bouchon de radiateur, avec chaîne ES Tapa del radiador, con cadena PT Tampa radiador, com corrente RU Крышка радиатора, с цепью 	0,7 bar 	000 501 7215	02.21758 
BM 625/652/654/655, 656/658/659	<ul style="list-style-type: none"> EN Radiator cap DE Kühlerverschluss FR Bouchon de radiateur ES Tapón del radiador PT Tampa radiador RU Пробка радиатора 		000 501 6415	02.21756 
BM 625/652/653/654, 655/656/657/658, 659	<ul style="list-style-type: none"> EN Level sensor DE Niveaugeber FR Jauge ES Sensor de nivel PT Sensor nível RU Датчик уровня 		655 542 0017	02.21917 

Application	Description	Details	Ref.	Erqo No.
MB 387/389, 393/395 (--chassis 4 367398)	<ul style="list-style-type: none"> EN Radiator hose to expansion tank DE Kühlerschlauch zum Ausgleichbehälter FR Durite de radiateur au vase d'expansion ES Manguito al deposito expansion PT Mangueira radiador ao deposito expansão RU Патрубок радиатора к расширительному бачку 		387 501 2882	02.21768 
				
BM 383/385, 387/389, 393/395 (chassis 367399--) BM 620/621/622/ 623/624/625, BM 655/656/657/658/659	<ul style="list-style-type: none"> EN Radiator hose to expansion tank DE Kühlerschlauch zum Ausgleichbehälter FR Durite de radiateur au vase d'expansion ES Manguito al deposito expansion PT Mangueira radiador ao deposito expansão RU Патрубок радиатора к расширительному бачку 		387 501 1082	02.21762 
				
BM 381/383/385/ 387/389/393/395, B M 620/621/622/ 623/624	<ul style="list-style-type: none"> EN Radiator hose to expansion tank DE Kühlerschlauch zum Ausgleichbehälter FR Durite de radiateur au vase d'expansion ES Manguito al deposito expansion PT Mangueira radiador ao deposito expansão RU Патрубок радиатора к расширительному бачку 		387 501 1782	02.21767 
				

Application	Description	Details	Ref.	Erqo No.
BM 625, BM 655/656/657/ 658/659	<p>EN Radiator hose to expansion tank right hand drive</p> <p>DE Kühlerschlauch zum Ausgleichbehälter Rechtslenkung</p> <p>FR Tuyau du radiateur au vase d'expansion volant à droite</p> <p>ES Manguera del refrigerador al deposito expansion volante lado derecho</p> <p>PT Mangueira radiador ao deposito expansão volante lado direito</p> <p>RU Патрубок радиатора к расширительному бачку Правостороннее управление</p>		655 506 0335	02.21842 
BM 616/617/619, BM 621	<p>EN Radiator hose to water pump</p> <p>DE Kühlerschlauch zur Wasserpumpe</p> <p>FR Tuyau du radiateur a pompe à eau</p> <p>ES Manguera del refrigerador a la bomba agua</p> <p>PT Mangueira radiador a bomba agua</p> <p>RU Патрубок радиатора к водяному насосу</p>		616 501 0682	02.21770 
BM 625, BM 655/656/657/ 658/659	<p>EN Radiator hose to expansion tank right hand drive</p> <p>DE Kühlerschlauch zum Ausgleichbehälter Rechtslenkung</p> <p>FR Tuyau du radiateur au vase d'expansion volant à droite</p> <p>ES Manguera del refrigerador al deposito expansion volante lado derecho</p> <p>PT Mangueira radiador ao deposito expansão volante lado direito</p> <p>RU Патрубок радиатора к расширительному бачку Правостороннее управление</p>		655 501 3382	02.21801 

Application	Description	Details	Ref.	Erqo No.
BM 625, BM 655/656, 659	<ul style="list-style-type: none"> EN Radiator hose to expansion tank DE Kühlerschlauch zum Ausgleichbehälter FR Tuyau du radiateur au vase d'expansion ES Manguera del refrigerador al deposito expansion PT Mangueira radiador ao deposito expansão RU Патрубок радиатора к расширительному бачку 		655 501 5382	02.21806 
BM 387/389, 393/395 (-- chassis 4 367398), BM 620/621/622/623/ 624/625, B M 645/646/647/ 648/649	<ul style="list-style-type: none"> EN Radiator hose to expansion tank DE Kühlerschlauch zum Ausgleichbehälter FR Durite de radiateur au vase d'expansion ES Manguera del refrigerador al deposito expansion PT Mangueira radiador ao deposito expansão RU Патрубок радиатора к расширительному бачку 		387 501 1682	02.21766 
BM 387/389, 393/395 (chassis 4 367399--), BM 620/621/622/ 623/624	<ul style="list-style-type: none"> EN Radiator hose to expansion tank DE Kühlerschlauch zum Ausgleichbehälter FR Durite de radiateur au vase d'expansion ES Manguera del refrigerador al deposito expansion PT Mangueira radiador ao deposito expansão RU Патрубок радиатора к расширительному бачку 		387 501 1482	02.21764 
BM 620/621/622/623/ 624/625, BM 645/646/647/ 648/649	<ul style="list-style-type: none"> EN Radiator hose heating DE Kühlerschlauch Heizung FR Durite de radiateur chauffage ES Manguera del refrigerador calefacción PT Mangueira radiador aquecimento RU Патрубок радиатора нагрев 		620 506 0335	02.21838 

THE ORIGINAL NUMBERS OF THE VEHICLE MANUFACTURER MAY BE USED FOR COMPARISON PURPOSES ONLY AND MUST NOT BE MENTIONED ON INVOICES TO VEHICLE OWNERS.







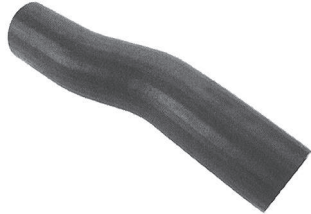

Application	Description	Details	Ref.	Erqo No.
BM 620/621/622/623/ 624/625, BM 645/646/647/ 648/649	<ul style="list-style-type: none"> EN Radiator hose heating DE Kühlerschlauch Heizung FR Durite de radiateur chauffage ES Manguera del refrigerador calefacción PT Mangueira radiador aquecimento RU Патрубок радиатора нагрев 		620 506 0235	02.21837 
BM 387/389, 393/395, BM 620/621/622/ 623/624	<ul style="list-style-type: none"> EN Radiator hose heating DE Kühlerschlauch Heizung FR Durite de radiateur chauffage ES Manguera del refrigerador calefacción PT Mangueira radiador aquecimento RU Патрубок радиатора нагрев 		387 506 0135	02.21833 
BM 381/383/385/387/ 393/395, BM 616/617/619 BM 620/621/622/623/ 624/625	<ul style="list-style-type: none"> EN Radiator hose heating DE Kühlerschlauch Heizung FR Durite de radiateur chauffage ES Manguera del refrigerador calefacción PT Mangueira radiador aquecimento RU Патрубок радиатора нагрев 		383 506 0035	02.21832 
BM 620/621/622/ 623/624, B M 645/646/647/ 648/649	<ul style="list-style-type: none"> EN Radiator hose heating DE Kühlerschlauch Heizung FR Durite de radiateur chauffage ES Manguera del refrigerador calefacción PT Mangueira radiador aquecimento RU Патрубок радиатора нагрев 		620 506 2035	02.21840 

Application	Description	Details	Ref.	Erqo No.
BM 381/383/385/387/ 393/395, BM 616/617/619 BM 620/621/622/623/ 624/625	<ul style="list-style-type: none"> EN Radiator hose water pump DE Kühlerschlauch Wasserpumpe FR Durite de radiateur pompe à eau ES Manguera del refrigerador bomba agua PT Mangueira radiador bomba agua RU Патрубок радиатора водяному насосу 		363 506 0235	02.21831 
BM 387/389, 393/395	<ul style="list-style-type: none"> EN Radiator hose to expansion tank DE Kühlerschlauch zum Ausgleichbehälter FR Durite de radiateur au vase d'expansion ES Manguera del refrigerador al deposito expansion PT Mangueira radiador ao deposito expansão RU Патрубок радиатора к расширительному бачку 		387 501 1282	02.21763 
BM 616/617/619, 625	<ul style="list-style-type: none"> EN Radiator hose to thermostat DE Kühlerschlauch zum Thermostat FR Durite de radiateur au thermostat ES Manguera del refrigerador al termostato PT Mangueira radiador ao termostato RU Патрубок радиатора к Термостат 		617 501 0082	02.21771 
BM 617 (--chassis 4 923838)	<ul style="list-style-type: none"> EN Radiator hose to expansion tank DE Kühlerschlauch zum Ausgleichbehälter FR Durite de radiateur au vase d'expansion ES Manguera del refrigerador al deposito expansion PT Mangueira radiador ao deposito expansão RU Патрубок радиатора к расширительному бачку 		617 501 0282	02.23249 

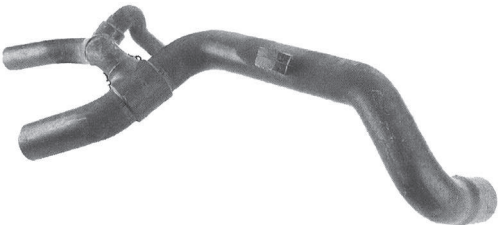
THE ORIGINAL NUMBERS OF THE VEHICLE MANUFACTURER MAY BE USED FOR COMPARISON PURPOSES ONLY AND MUST NOT BE MENTIONED ON INVOICES TO VEHICLE OWNERS.





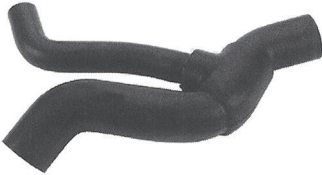

Application	Description	Details	Ref.	Erqo No.
BM 616/617/619, 625 (Chassis 4 923839--)	<ul style="list-style-type: none"> EN Radiator hose to expansion tank DE Kühlerschlauch zum Ausgleichbehälter FR Durite de radiateur au vase d'expansion ES Manguera del refrigerador al deposito expansion PT Mangueira radiador ao deposito expansão RU Патрубок радиатора к расширительному бачку 		617 501 2782	02.21772 
BM 387/389, 393/395, BM 620/621/622/ 623/624	<ul style="list-style-type: none"> EN Radiator hose to water pump DE Kühlerschlauch zur Wasserpumpe FR Durite de radiateur a pompe à eau ES Manguera del refrigerador a la bomba agua PT Mangueira radiador a bomba agua RU Патрубок радиатора к водяному насосу 		387 501 2982	02.21769 
BM 620/621/622/ 623/624	<ul style="list-style-type: none"> EN Radiator hose to water pump DE Kühlerschlauch zur Wasserpumpe FR Durite de radiateur a pompe à eau ES Manguera del refrigerador a la bomba agua PT Mangueira radiador a bomba agua RU Патрубок радиатора к водяному насосу 		620 501 0382	02.21775 
BM 620/621/622/ 623/624 (Chassis 5 1935595), 625	<ul style="list-style-type: none"> EN Radiator hose to water pump DE Kühlerschlauch zur Wasserpumpe FR Durite de radiateur a pompe à eau ES Manguera del refrigerador a la bomba agua PT Mangueira radiador a bomba agua RU Патрубок радиатора к водяному насосу 		620 501 3682	02.21785 

Application	Description	Details	Ref.	Erqo No.
BM 625, BM 655/656/657/ 658/659 (- 5 923089)	<ul style="list-style-type: none"> EN Radiator hose to water pump DE Kühlerschlauch zur Wasserpumpe FR Durite de radiateur a pompe à eau ES Manguera del refrigerador a la bomba agua PT Mangueira radiador a bomba agua RU Патрубок радиатора к водяному насосу 		655 501 1182	02.21794
BM 620/621/622/ 623/624 (--chassis 5 1935 594)	<ul style="list-style-type: none"> EN Radiator hose to water pump DE Kühlerschlauch zur Wasserpumpe FR Durite de radiateur a pompe à eau ES Manguera del refrigerador a la bomba agua PT Mangueira radiador a bomba agua RU Патрубок радиатора к водяному насосу 		620 501 0482	02.21776
BM 620/621/622/623/ 624/625 (chassis 5 1935595--), BM 645/646/647/ 648/649, BM 652/653/654/655/ 656/657/658/659	<ul style="list-style-type: none"> EN Radiator hose to water pump DE Kühlerschlauch zur Wasserpumpe FR Durite de radiateur a pompe à eau ES Manguera del refrigerador a la bomba agua PT Mangueira radiador a bomba agua RU Патрубок радиатора к водяному насосу 		655 501 1282	02.21795
B M 620/621/622/ 623/624	<ul style="list-style-type: none"> EN Radiator hose to water pump DE Kühlerschlauch zur Wasserpumpe FR Durite de radiateur a pompe à eau ES Manguera del refrigerador a la bomba agua PT Mangueira radiador a bomba agua RU Патрубок радиатора к водяному насосу 		620 501 0682	02.21761



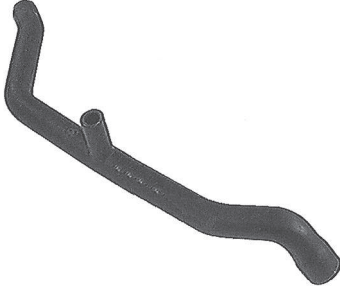



Application	Description	Details	Ref.	Erqo No.
BM 620/621/622/ 623/624 (chassis 5 193595--), BM 645/646/ 648/649, BM 655/656/657/ 658/659	<p>EN Radiator hose to water pump</p> <p>DE Kühlerschlauch zur Wasserpumpe</p> <p>FR Durite de radiateur a pompe à eau</p> <p>ES Manguera del refrigerador a la bomba agua</p> <p>PT Mangueira radiador a bomba agua</p> <p>RU Патрубок радиатора к водяному насосу</p>		620 501 3782	02.21786 
BM 616/617	<p>EN Radiator hose to water pump</p> <p>DE Kühlerschlauch zur Wasserpumpe</p> <p>FR Durite de radiateur a pompe à eau</p> <p>ES Manguera del refrigerador a la bomba agua</p> <p>PT Mangueira radiador a bomba agua</p> <p>RU Патрубок радиатора к водяному насосу</p>		617 501 3482	02.21773 
BM 387/389, 393/395 (--Chassis 4 367398)	<p>EN Radiator hose to thermostat</p> <p>DE Kühlerschlauch zum Thermostat</p> <p>FR Durite de radiateur au thermostat</p> <p>ES Manguera del refrigerador al termostato</p> <p>PT Mangueira radiador ao termostato</p> <p>RU Патрубок радиатора к Термостат</p>		387 501 1582	02.21765 
BM 387/389, 393/395 (chassis 4 367399--), BM 620/621/622/ 623/624	<p>EN Radiator hose to thermostat</p> <p>DE Kühlerschlauch zum Thermostat</p> <p>FR Durite de radiateur au thermostat</p> <p>ES Manguera del refrigerador al termostato</p> <p>PT Mangueira radiador ao termostato</p> <p>RU Патрубок радиатора к Термостат</p>		387 501 0982	02.21761 









Application	Description	Details	Ref.	Erqo No.
BM 620/621/622/623/ 624/625, BM 645/646/647/ 648/649	<p>EN Radiator hose to thermostat</p> <p>DE Kühlerschlauch zum Thermostat</p> <p>FR Durite de radiateur au thermostat</p> <p>ES Manguera del refrigerador al termostato</p> <p>PT Mangueira radiador ao termostato</p> <p>RU Патрубок радиатора к Термостат</p>		620 501 1082	02.21778 
BM 383, 387/389, 395 BM 621, 624	<p>EN Radiator hose to thermostat</p> <p>DE Kühlerschlauch zum Thermostat</p> <p>FR Durite de radiateur au thermostat</p> <p>ES Manguera del refrigerador al termostato</p> <p>PT Mangueira radiador ao termostato</p> <p>RU Патрубок радиатора к Термостат</p>		387 501 0582	02.21759 
BM 621, 624/625 BM 655/656, 659	<p>EN Radiator hose to thermostat</p> <p>DE Kühlerschlauch zum Thermostat</p> <p>FR Durite de radiateur au thermostat</p> <p>ES Manguera del refrigerador al termostato</p> <p>PT Mangueira radiador ao termostato</p> <p>RU Патрубок радиатора к Термостат</p>		617 501 4982	02.21774 
B M 620/621/622/ 623/624, B M 645/646, 648/649	<p>EN Radiator hose to thermostat</p> <p>DE Kühlerschlauch zum Thermostat</p> <p>FR Durite de radiateur au thermostat</p> <p>ES Manguera del refrigerador al termostato</p> <p>PT Mangueira radiador ao termostato</p> <p>RU Патрубок радиатора к Термостат</p>		620 501 2982	02.21783 







Application	Description	Details	Ref.	Erqo No.
BM 616/617/619, BM 620/621/622/623/ 624/625, BM 645/646/647/648	<p>EN Radiator hose to expansion tank</p> <p>DE Kühlerschlauch zum Ausgleichbehälter</p> <p>FR Durite de radiateur au vase d'expansion</p> <p>ES Manguera del refrigerador al deposito expansion</p> <p>PT Mangueira radiador ao deposito expansão</p> <p>RU Патрубок радиатора к расширительному бачку</p>		620 501 2882	02.21782 
BM 620/621/622/ 623/624, BM 645/646/647/ 648/649	<p>EN Radiator hose to expansion tank left hand drive</p> <p>DE Kühlerschlauch zum Ausgleichbehälter Linkslenkung</p> <p>FR Durite de radiateur au vase d'expansion volant à gauche</p> <p>ES Manguera del refrigerador al deposito expansion volante lado izquierdo</p> <p>PT Mangueira radiador ao deposito expansão volante lado esquerdo</p> <p>RU Патрубок радиатора к расширительному бачку Левостороннее управление</p>		620 501 2082	02.21781 
BM 620/621/622/ 623/624, BM 645/646/647/ 648/649	<p>EN Radiator hose to expansion tank right hand drive</p> <p>DE Kühlerschlauch zum Ausgleichbehälter Rechtslenkung</p> <p>FR Durite de radiateur au vase d'expansion volant à droite</p> <p>ES Manguera del refrigerador al deposito expansion volante lado derecho</p> <p>PT Mangueira radiador ao deposito expansão volante lado direito</p> <p>RU Патрубок радиатора к расширительному бачку Правостороннее управление</p>		620 501 1882	02.21779 



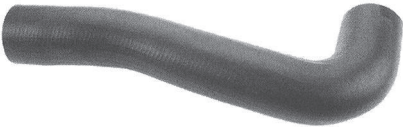



Application	Description	Details	Ref.	Erqo No.
BM 620/621/622/ 623/624, B M 645/646/647/ 648/649	<p>EN Radiator hose to expansion tank right hand drive</p> <p>DE Kühlerschlauch zum Ausgleichbehälter Rechtslenkung</p> <p>FR Durite de radiateur au vase d'expansion volant à droite</p> <p>ES Manguera del refrigerador al deposito expansion volante lado derecho</p> <p>PT Mangueira radiador ao deposito expansão volante lado direito</p> <p>RU Патрубок радиатора к расширительному бачку Правостороннее управление</p>		658 501 0082	02.21815 
BM 620/621/622/ 623/624 (--chassis 5 017485)	<p>EN Radiator hose to expansion tank</p> <p>DE Kühlerschlauch zum Ausgleichbehälter</p> <p>FR Durite de radiateur au vase d'expansion</p> <p>ES Manguera del refrigerador al deposito expansion</p> <p>PT Mangueira radiador ao deposito expansão</p> <p>RU Патрубок радиатора к расширительному бачку</p>		620 501 1982	02.21780 
BM 620/621/622/ 623/624 (chassis 5 017486--), B M 645/646/ 648/649	<p>EN Radiator hose to expansion tank</p> <p>DE Kühlerschlauch zum Ausgleichbehälter</p> <p>FR Durite de radiateur au vase d'expansion</p> <p>ES Manguera del refrigerador al deposito expansion</p> <p>PT Mangueira radiador ao deposito expansão</p> <p>RU Патрубок радиатора к расширительному бачку</p>		620 501 3082	02.21784 









Application	Description	Details	Ref.	Erqo No.
BM 620/621/622/623/ 624/625	<ul style="list-style-type: none"> EN Radiator hose heating DE Kühlerschlauch Heizung FR Durite de radiateur chauffage ES Manguera del refrigerador calefacción PT Mangueira radiador aquecimento RU Патрубок радиатора нагрев 		620 506 0035	02.21836 
BM 625, BM 652, 655/656/ 657/658/659	<ul style="list-style-type: none"> EN Radiator hose to thermostat DE Kühlerschlauch zum Thermostat FR Durite de radiateur au thermostat ES Manguera del refrigerador al termostato PT Mangueira radiador ao termostato RU Патрубок радиатора к Термостат 		655 501 1082	02.21793 
BM 625, BM 652, 656, 659	<ul style="list-style-type: none"> EN Radiator hose to thermostat DE Kühlerschlauch zum Thermostat FR Durite de radiateur au thermostat ES Manguera del refrigerador al termostato PT Mangueira radiador ao termostato RU Патрубок радиатора к Термостат 		655 501 5282	02.21805 
BM 625, BM 652, 655/656, 659 (K 023231--)	<ul style="list-style-type: none"> EN Radiator Hose to thermostat DE Kühlerschlauch zum Thermostat FR Durite de radiateur au thermostat ES Manguera del refrigerador al termostato PT Mangueira radiador ao termostato RU Шланг радиатора к Термостат 		655 501 5582	02.21807 









Application	Description	Details	Ref.	Erqo No.
BM 625, BM 655/656/657/ 658/659	<ul style="list-style-type: none"> EN Radiator hose to thermostat DE Kühlerschlauch zum Thermostat FR Durite de radiateur au thermostat ES Manguera del refrigerador al termostato PT Mangueira radiador ao termostato RU Патрубок радиатора к Термостат 		655 501 4082	02.21803 
BM 625, BM 655/656/657/ 658/659	<ul style="list-style-type: none"> EN Radiator hose to expansion tank left hand drive DE Kühlerschlauch zum Ausgleichbehälter Linkslenkung FR Durite de radiateur au vase d'expansion volant à gauche ES Manguera del refrigerador al deposito expansion volante lado izquierdo PT Mangueira radiador ao deposito expansão volante lado esquerdo RU Патрубок радиатора к расширительному бачку Левостороннее управление 		655 501 0482	02.21792 
BM 625, BM 652/653/654/ 655/656/657/658/659	<ul style="list-style-type: none"> EN Radiator hose to expansion tank DE Kühlerschlauch zum Ausgleichbehälter FR Durite de radiateur au vase d'expansion ES Manguera del refrigerador al deposito expansion PT Mangueira radiador ao deposito expansão RU Патрубок радиатора к расширительному бачку 		655 501 1482	02.21798 





Application	Description	Details	Ref.	Erqo No.
BM 620/621/622/623/ 624/625 (chassis 5 1935595--), BM 645/646/647/ 648/649, BM 652/653/654/655/ 656/657/658/659	<ul style="list-style-type: none"> EN Radiator hose to water pump DE Kühlerschlauch zur Wasserpumpe FR Durite de radiateur a pompe à eau ES Manguera del refrigerador a la bomba agua PT Mangueira radiador a bomba agua RU Патрубок радиатора к водяному насосу 		655 501 1282	02.21796 
BM 625, BM 652, 655/656, 659 (--K037736)	<ul style="list-style-type: none"> EN Radiator hose to water pump DE Kühlerschlauch zur Wasserpumpe FR Durite de radiateur a pompe à eau ES Manguera del refrigerador a la bomba agua PT Mangueira radiador a bomba agua RU Патрубок радиатора к водяному насосу 		655 501 1382	02.21797 
BM 625, BM 655/656, 659 (K037737--)	<ul style="list-style-type: none"> EN Radiator hose to water pump DE Kühlerschlauch zur Wasserpumpe FR Durite de radiateur a pompe à eau ES Manguera del refrigerador a la bomba agua PT Mangueira radiador a bomba agua RU Патрубок радиатора к водяному насосу 		655 501 5882	02.21808 
BM 625, BM 649, BM 652/653/654/ 655/656/657/658/659	<ul style="list-style-type: none"> EN Radiator hose to water pump DE Kühlerschlauch zur Wasserpumpe FR Durite de radiateur a pompe à eau ES Manguera del refrigerador a la bomba agua PT Mangueira radiador a bomba agua RU Патрубок радиатора к водяному насосу 		655 501 4982	02.21804 

Application	Description	Details	Ref.	Erqo No.
BM 625, BM 652/653/654/ 655/656/657/658/659	<p>EN Radiator hose to thermostat</p> <p>DE Kühlerschlauch zum Thermostat</p> <p>FR Durite de radiateur au thermostat</p> <p>ES Manguera del refrigerador al termostato</p> <p>PT Mangueira radiador ao termostato</p> <p>RU Патрубок радиатора к Термостат</p>		652 501 2082	02.21787 
BM 625, BM 652/653/654/ 655/656/657/658/659 (--K037736)	<p>EN Radiator hose to expansion tank left hand drive</p> <p>DE Kühlerschlauch zum Ausgleichbehälter</p> <p>FR Linkslenkung Durite de radiateur au vase d'expansion</p> <p>ES Manguera del refrigerador al deposito expansion</p> <p>PT Mangueira radiador ao deposito expansão</p> <p>RU Патрубок радиатора к расширительному бачку</p>		652 501 2282	02.21788 
BM 625, BM 652/653/654/ 655/656/657/658/659 (K037737--)	<p>EN Radiator hose to expansion tank left hand drive</p> <p>DE Kühlerschlauch zum Ausgleichbehälter</p> <p>FR Linkslenkung Durite de radiateur au vase d'expansion</p> <p>ES Manguera del refrigerador al deposito expansion</p> <p>PT Mangueira radiador ao deposito expansão</p> <p>RU Патрубок радиатора к расширительному бачку</p>		656 501 1482	02.21810 









Application	Description	Details	Ref.	Erqo No.
BM 625, BM 652, 655/656, 659 (K148451--)	<p>EN Radiator hose to expansion tank left hand drive</p> <p>DE Kühlerschlauch zum Ausgleichbehälter</p> <p>FR Linkslenkung Durite de radiateur au vase d'expansion</p> <p>ES Manguera del refrigerador al deposito expansion</p> <p>PT Mangueira radiador ao deposito expansão</p> <p>RU Патрубок радиатора к расширительному бачку</p>		656 501 2182	02.21814 
BM 625, BM 652/653/654/ 655/656/657/658/659 (--K037736)	<p>EN Radiator hose to expansion tank right hand drive</p> <p>DE Kühlerschlauch zum Ausgleichbehälter Rechtslenkung</p> <p>FR Durite de radiateur au vase d'expansion volant à droite</p> <p>ES Manguera del refrigerador al deposito expansion volante lado derecho</p> <p>PT Mangueira radiador ao deposito expansão volante lado direito</p> <p>RU Патрубок радиатора к расширительному бачку Правостороннее управление</p>		652 501 5282	02.21791 
BM 625, BM 652/653/654/ 655/656/657/658/659 (K037737--)	<p>EN Radiator hose to expansion tank right hand drive</p> <p>DE Kühlerschlauch zum Ausgleichbehälter Rechtslenkung</p> <p>FR Durite de radiateur au vase d'expansion volant à droite</p> <p>ES Manguera del refrigerador al deposito expansion volante lado derecho</p> <p>PT Mangueira radiador ao deposito expansão volante lado direito</p> <p>RU Патрубок радиатора к расширительному бачку Правостороннее управление</p>		656 501 1782	02.21811 









Application	Description	Details	Ref.	Erqo No.
BM 655/656, 659 (K103232--)	<p>EN Radiator hose to expansion tank right hand drive</p> <p>DE Kühlerschlauch zum Ausgleichbehälter Rechtslenkung</p> <p>FR Durite de radiateur au vase d'expansion volant à droite</p> <p>ES Manguera del refrigerador al deposito expansion volante lado derecho</p> <p>PT Mangueira radiador ao deposito expansão volante lado direito</p> <p>RU Патрубок радиатора к расширительному бачку Правостороннее управление</p>		656 501 2082	02.21813 
2650, 3535, 3550, 1735,1929,1935, 1945, 2529, 2635	<p>EN Radiator hose</p> <p>DE Kühlerschlauch</p> <p>FR Durite de radiateur</p> <p>ES Manguera del refrigerador</p> <p>PT Mangueira radiador</p> <p>RU Патрубок радиатора</p>		656 506 0135	02.21846 
1922,1929, 2429, 2435	<p>EN Radiator hose</p> <p>DE Kühlerschlauch</p> <p>FR Durite de radiateur</p> <p>ES Manguito</p> <p>PT Mangueira radiador</p> <p>RU Патрубок радиатора</p>		656 506 0235	02.21847 
1922, 1929, 2429, 2435	<p>EN Radiator hose</p> <p>DE Kühlerschlauch</p> <p>FR Durite de radiateur</p> <p>ES Manguito</p> <p>PT Mangueira radiador</p> <p>RU Патрубок радиатора</p>		656 506 0035	02.21845 





Application	Description	Details	Ref.	Erqo No.
BM 625, BM 652/653/654/ 655/656/657/658/659 (--K037736)	<ul style="list-style-type: none"> EN Radiator hose right hand drive DE Kühlerschlauch Rechtslenkung FR Durite de radiateur volant à droite ES Manguera del refrigerador volante lado derecho PT Mangueira radiador volante lado direito RU Патрубок радиатора Правостороннее управление 		435 506 0535	02.21835 
BM 625, BM 652/653/654/ 655/656/657/658/659 (K037737--)	<ul style="list-style-type: none"> EN Radiator hose right hand drive DE Kühlerschlauch Rechtslenkung FR Durite de radiateur volant à droite ES Manguera del refrigerador volante lado derecho PT Mangueira radiador volante lado direito RU Патрубок радиатора Правостороннее управление 		656 501 1882	02.21812 
BM 655/656/657/ 658/659 (5 528984 --)	<ul style="list-style-type: none"> EN Radiator hose to expansion tank DE Kühlerschlauch zum Ausgleichbehälter FR Durite de radiateur au vase d'expansion ES Manguera del refrigerador al deposito expansion PT Mangueira radiador ao deposito expansão RU Патрубок радиатора к расширительному бачку 		655 501 3882	02.21802 
BM 655/656/658/659 (5 464667 - 5 528893)	<ul style="list-style-type: none"> EN Radiator hose to expansion tank DE Kühlerschlauch zum Ausgleichbehälter FR Durite de radiateur au vase d'expansion ES Manguera del refrigerador al deposito expansion PT Mangueira radiador ao deposito expansão RU Патрубок радиатора к расширительному бачку 		655 501 3082	02.21800 

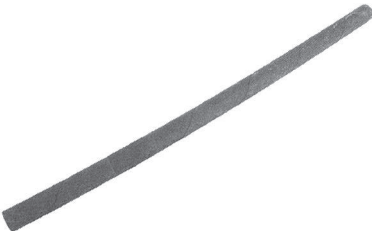

Application	Description	Details	Ref.	Erqo No.
BM 625, BM 652/653/654/ 655/656/657/658/659	<ul style="list-style-type: none"> EN Radiator hose to radiator DE Kühlerschlauch zum Kühler FR Durite de radiateur au radiateur ES Manguera del refrigerador al radiador PT Mangueira radiador ao radiador RU Патрубок радиатора к Радиатор 		656 501 0382	02.21809 
BM 625, BM 652/653/654/ 655/656/657/658/659	<ul style="list-style-type: none"> EN Radiator hose heater pipe at engine to heater pipe at radiator left hand drive DE Kühlerschlauch Heizungsrohr am Motor zum Heizungsrohr am Kühler Linkslenkung FR Durite de radiateur Manguera del refrigerador Mangueira radiador Патрубок радиатора 		652 501 2482	02.21790 
BM 625, BM 652/652/654/ 655/656/657/658/659 (--K037736)	<ul style="list-style-type: none"> EN Radiator hose right hand drive DE Kühlerschlauch Rechtslenkung FR Durite de radiateur volant à droite ES Manguera del refrigerador volante lado derecho PT Mangueira radiador volante lado direito RU Патрубок радиатора Правостороннее управление 		655 506 0035	02.21841 
BM 625, BM 652/653/655/ 656/657/658 (K037737--)	<ul style="list-style-type: none"> EN Radiator hose right hand drive DE Kühlerschlauch Rechtslenkung FR Durite de radiateur volant à droite ES Manguera del refrigerador volante lado derecho PT Mangueira radiador volante lado direito RU Патрубок радиатора Правостороннее управление 		656 506 0635	02.21848 

THE ORIGINAL NUMBERS OF THE VEHICLE MANUFACTURER MAY BE USED FOR COMPARISON PURPOSES ONLY AND MUST NOT BE MENTIONED ON INVOICES TO VEHICLE OWNERS.

Application	Description	Details	Ref.	Erqo No.
BM 625, BM 652/653/654/ 655/656/657/658/659	<ul style="list-style-type: none"> EN Radiator hose heating DE Kühlerschlauch Heizung FR Durite de radiateur chauffage ES Manguera del refrigerador calefacción PT Mangueira radiador aquecimento RU Патрубок радиатора нагрев 		655 506 0535	02.21843 
BM 625, BM 652/653/654/ 655/656/657/658/659	<ul style="list-style-type: none"> EN Radiator hose heating DE Kühlerschlauch Heizung FR Durite de radiateur chauffage ES Manguera del refrigerador calefacción PT Mangueira radiador aquecimento RU Патрубок радиатора нагрев 		655 506 0635	02.21844 
BM 655/656/657/ 658/659	<ul style="list-style-type: none"> EN Radiator hose to expansion tank DE Kühlerschlauch zum Ausgleichbehälter FR Durite de radiateur au vase d'expansion ES Manguera del refrigerador al deposito expansion PT Mangueira radiador ao deposito expansão RU Патрубок радиатора к расширительному бачку 		655 501 2082	02.21799 
BM 653/654/655/ 656/657/658/659	<ul style="list-style-type: none"> EN Radiator hose to expansion tank DE Kühlerschlauch zum Ausgleichbehälter FR Durite de radiateur au vase d'expansion ES Manguera del refrigerador al deposito expansion PT Mangueira radiador ao deposito expansão RU Патрубок радиатора к расширительному бачку 		652 501 2382	02.21789 

Application	Description	Details	Ref.	Erqo No.
BM 616/617/619, BM 620/621/622/ 623/624/625, BM 645/646/647/ 648/649	<ul style="list-style-type: none"> EN Radiator hose expansion tank DE Kühlerschlauch Ausgleichbehälter FR Durite de radiateur vase d'expansion ES Manguera del refrigerador deposito expansion PT Mangueira radiador deposito expansão RU Патрубок радиатора расширительному бачку 		014 997 5782	02.22760 
BM 381/383/385/ 387, 395 BM624	<ul style="list-style-type: none"> EN Radiator hose heating DE Kühlerschlauch Heizung FR Durite de radiateur chauffage ES Manguera del refrigerador calefacción PT Mangueira radiador aquecimento RU Шланг радиатора нагрев 		387 506 0235	02.21834 
BM 620/621/622/ 623/624/625, BM 649, BM 652, 655/656	<ul style="list-style-type: none"> EN Radiator hose heating DE Kühlerschlauch Heizung FR Durite de radiateur chauffage ES Manguera del refrigerador calefacción PT Mangueira radiador aquecimento RU Шланг радиатора нагрев 		620 506 0635	02.21839 
BM 625, BM 652, 655/656/ 657/658/659 (--K 131865)	<ul style="list-style-type: none"> EN Radiator Hose DE Kühlerschlauch FR Durite de radiateur ES Manguera del refrigerador PT Mangueira radiador RU Шланг радиатора 		655 997 0582	02.22769 

Application	Description	Details	Ref.	Erqo No.
BM 625, BM 652, 655/656/ 657/658/659 (K 131866 --)	<p>EN Hose oil cooler</p> <p>DE Schlauch Ölkühler</p> <p>FR Tuyau radiateur d'huile</p> <p>ES Tubo flexible radiador de aceite</p> <p>PT Mangueira radiador óleo</p> <p>RU Шланг Масляный радиатор</p>		655 997 3782	02.22770 
BM 625, BM 652, 655/656/ 657/658/659 (K 131866 --)	<p>EN Hose oil cooler</p> <p>DE Schlauch Ölkühler</p> <p>FR Tuyau radiateur d'huile</p> <p>ES Tubo flexible radiador de aceite</p> <p>PT Mangueira radiador óleo</p> <p>RU Шланг Масляный радиатор</p>		655 997 4482	02.22771 

Application	Description	Details	Ref.	Erqo No.
BM 650.284, 652.302/303, 655.307/337, 656.205/302/309, 656.332, 659.203/242/301, 659.303/304/341, 659.343/344	<p>EN Intercooler</p> <p>DE Ladeluftkühler</p> <p>FR Radiateur d'air</p> <p>ES Intercooler, refrigerador del aire de admisión</p> <p>PT Radiador ar</p> <p>RU Охладитель воздуха</p>	593 x 792 mm	656 501 0101	02.21749 
Sample				
BM 625, 655/656/657/658, 659	<p>EN Intercooler</p> <p>DE Ladeluftkühler</p> <p>FR Radiateur d'air</p> <p>ES Intercooler, refrigerador del aire de admisión</p> <p>PT Radiador ar</p> <p>RU Охладитель воздуха</p>	652 x 752 x 52 mm	655 501 0201	02.21747 
BM 625, 651/652/653/654, 655/656/657/658, 659	<p>EN Intercooler</p> <p>DE Ladeluftkühler</p> <p>FR Radiateur d'air</p> <p>ES Intercooler, refrigerador del aire de admisión</p> <p>PT Radiador ar</p> <p>RU Охладитель воздуха</p>	593 x 792 x 50 mm	656 501 0001	02.21748 

Application	Description	Details	Ref.	Erqo No.
BM 616/617/619, BM 652/653/654	<ul style="list-style-type: none"> EN Charge air hose DE Ladeluftschlauch FR Durite de radiateur d'air ES Manguito del aire de admisión PT Mangueira RU Шланг наддувочного воздуха 	Ø 78,5 mm / L: 215 mm	684 501 1082	02.21816 



BM 620/621/623/ 624/625, B M 645/646/ 648/649, BM 652/653/654/ 655/656/657/658/659	<ul style="list-style-type: none"> EN Charge air hose DE Ladeluftschlauch FR Durite intercooler ES Manguito del aire de admisión PT Mangueira RU Шланг наддувочного воздуха 	Ø 100 mm / L: 245 mm	002 094 5282	02.19897 
---	---	----------------------	--------------	---



BM 620/621/623/ 624/625, B M 645/646/ 648/649, BM 652/653/654/ 655/656/657/658/659	<ul style="list-style-type: none"> EN Charge air hose DE Ladeluftschlauch FR Durite intercooler ES Manguito del aire de admisión PT Mangueira RU Шланг наддувочного воздуха 	Ø 97 mm / L: 205 mm	002 094 6382	02.19899 
---	---	---------------------	--------------	---



BM 625/652/653/654, 655/656/657/658, 659	<ul style="list-style-type: none"> EN Hose clamp DE Schlauchschelle FR Bride de tuyau ES Abrazadera de manguera PT Abraçadeira RU Хомут 		000000 000676	02.22800 
---	---	--	---------------	---



Air FilterLuftfilter • Filtre à air • Filtro de Aire
Filtro de Ar • Воздушный фильтр

Application	Description	Details	Ref.	Erqo No.
NG/MK/SK	<ul style="list-style-type: none"> EN Air filter DE Luftfilter FR Filtre à air ES Filtro de aire PT Elemento filtro ar RU Воздушный фильтр 	repl. M+H C 28715	001 094 9304	02.19886



1

BM 383/385/387/389, 393/395, 615/616/617/619, 620/621/622/623, 624/625	<ul style="list-style-type: none"> EN Air filter DE Luftfilter FR Filtre à air ES Filtro de aire PT Elemento filtro ar RU Воздушный фильтр 	repl. M+H C 33922	001 094 8304	02.19885
---	--	-------------------	--------------	----------



BM 620/621/623/624, 645/646/648/649, 655/658	<ul style="list-style-type: none"> EN Air filter DE Luftfilter FR Filtre à air ES Filtro de aire PT Elemento filtro ar RU Воздушный фильтр 	repl. M+H C 331305	002 094 2404	02.19887
---	--	--------------------	--------------	----------



1

Application	Description	Details	Ref.	Erqo No.
BM 645/646/648, 655/656/658/659	<ul style="list-style-type: none"> EN Air filter DE Luftfilter FR Filtre à air ES Filtro de aire PT Elemento filtro ar RU Воздушный фильтр 	repl. M+H C 301537	003 094 1504	02.19888

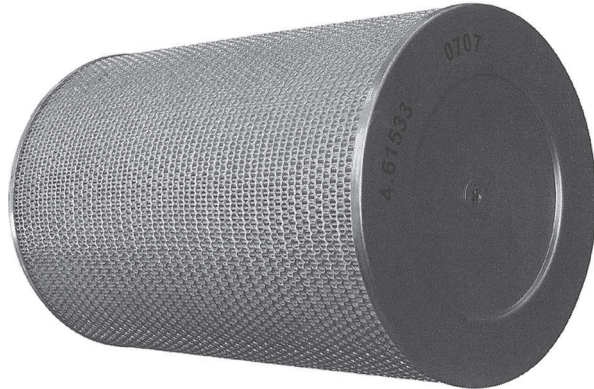



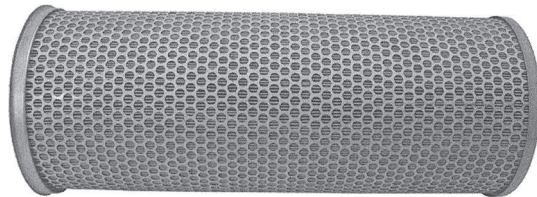

BM 371	<ul style="list-style-type: none"> EN Air filter, inner DE Luftfilter, innen FR Filtre à air, intérieur ES Filtro aire, interior PT Elemento filtro ar, interior RU Воздушный фильтр, внутренняя 	repl. M+H: CF 1600	003 094 1604	02.19889
-----------	--	--------------------	--------------	----------



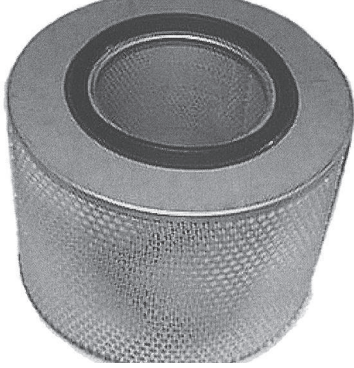

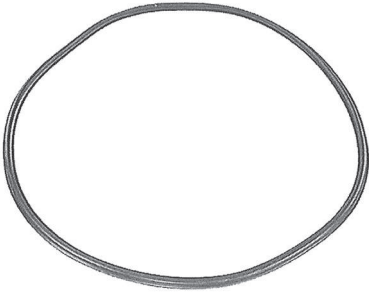

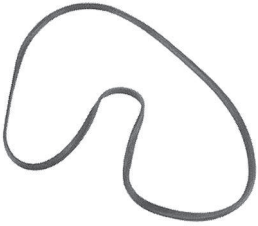
BM 655/656/658/659	<ul style="list-style-type: none"> EN Air filter DE Luftfilter FR Filtre à air ES Filtro de aire PT Elemento filtro ar RU Воздушный фильтр 	repl. M+H: C 331840	003 094 7004	02.19891
-----------------------	--	---------------------	--------------	----------





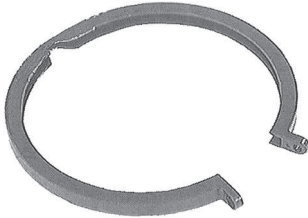



Application	Description	Details	Ref.	Erqo No.
BM 625, 650/651/652/653, 654/655/656/657, 658/659	<ul style="list-style-type: none"> EN Air filter DE Luftfilter FR Filtre à air ES Filtro de aire PT Elemento filtro ar RU Воздушный фильтр 	repl. M+H C 331015	003 094 4204	02.19890 
				
BM 621/624/625	<ul style="list-style-type: none"> EN Gasket inner DE Dichtung innen FR Joint intérieur ES Junta interior PT Junta interior RU Уплотнение внутренняя 		000 094 8080	02.19893 
				
BM 621/624/625	<ul style="list-style-type: none"> EN Gasket outer DE Dichtung außen FR Joint extérieur ES Junta exterior PT Junta exterior RU Уплотнение внешний 		000 094 7980	02.19892 
				
BM 645/646/648/649, 652/655/656/658, 659	<ul style="list-style-type: none"> EN Seal ring DE Dichtring FR Bague d'étanchéité ES Retén PT Anel vedação RU Уплотнительное кольцо 		001 094 8980	02.19894 
				

THE ORIGINAL NUMBERS OF THE VEHICLE MANUFACTURER MAY BE USED FOR COMPARISON PURPOSES ONLY AND MUST NOT BE MENTIONED ON INVOICES TO VEHICLE OWNERS.

Application	Description	Details	Ref.	Erqo No.
BM 381/383/385/ 387/389, 393/395, BM 616/617/619, BM 620/621/622/ 623/624/625	<ul style="list-style-type: none"> EN Boot DE Manschette FR Manchon ES Manguito de Aspiración PT Tubo sucção RU Манжета 		381 528 0191	02.21870 
				
BM 381/383/385/387, 389/391/393/395, 615/616/617/619, 620/621/622/623, 624/625	<ul style="list-style-type: none"> EN Clamp DE Schelle FR Collier ES Abrazadera PT Abraçadeira RU Хомут 		381 528 0443	02.21853 
				
BM 381/383/385/387, 389/391/393/395, 615/616/617/619, 620/621/622/623, 624/625	<ul style="list-style-type: none"> EN Hose clamp DE Schlauchschelle FR Collier de durite intercooler ES Abrazadera de manguera PT Abraçadeira RU Хомут 	108 - 130 mm	005 997 1490	02.22774 
				
BM 383/385/387/389, 393/395, BM 617, BM 620/621/622/623/624, BM652	<ul style="list-style-type: none"> EN Hose old version DE Schlauch alte Ausführung FR Durite ancienne version ES Tubo flexible version antigua PT Mangueira versão antiga RU Шланг старая версия 		001 094 2682	02.19896 
				

Application	Description	Details	Ref.	Erqo No.
BM 378/389, 393/395, BM 616/617/619, BM 620/621/622/623/ 624/625, BM 652/653/654/ 655/656/657/658/659	<p>EN Hose new version</p> <p>DE Schlauch neue Ausführung</p> <p>FR Durite nouvelle version</p> <p>ES Tubo flexible nueva versión</p> <p>PT Mangueira nova versão</p> <p>RU Шланг новая версия</p>		620 528 0782	02.21862 
BM 625, B M 645/646, 648/649, BM 655/656, 658/659	<p>EN Hose</p> <p>DE Schlauch</p> <p>FR Durite</p> <p>ES Tubo flexible</p> <p>PT Mangueira</p> <p>RU Шланг</p>		620 528 0682	02.21861 
BM 625, BM 645/646, 648/649, BM 652, 655/656/657/658/659	<p>EN Hose</p> <p>DE Schlauch</p> <p>FR Durite</p> <p>ES Tubo flexible</p> <p>PT Mangueira</p> <p>RU Шланг</p>		624 528 0282	02.21863 
BM 652/653/654	<p>EN Hose</p> <p>DE Schlauch</p> <p>FR Durite</p> <p>ES Tubo flexible</p> <p>PT Mangueira filtro ar</p> <p>RU Шланг</p>		652 528 0682	02.21865 

1

Application	Description	Details	Ref.	Erqo No.
BM 645/646/647/ 648/649, BM 652, 655/656/657/658/659	<ul style="list-style-type: none"> EN Hose DE Schlauch FR Durite ES Tubo flexible PT Mangueira RU Шланг 		645 528 0182	02.21864 
B M 620/621/622/ 623/624	<ul style="list-style-type: none"> EN Hose DE Schlauch FR Durite ES Tubo flexible PT Mangueira RU Шланг 		001 094 1182	02.19895 
BM 620/621/622/ 623/624	<ul style="list-style-type: none"> EN Boot DE Manschette FR Manchon ES Retén PT Guarda-ró eixo RU Манжета 		620 520 0296	02.21850 
BM 625, BM 647, BM657	<ul style="list-style-type: none"> EN Hose DE Schlauch FR Durite ES Tubo flexible PT Mangueira RU Шланг 		657 528 0082	02.21868 

THE ORIGINAL NUMBERS OF THE VEHICLE MANUFACTURER MAY BE USED FOR COMPARISON PURPOSES ONLY AND MUST NOT BE MENTIONED ON INVOICES TO VEHICLE OWNERS.

Application	Description	Details	Ref.	Erqo No.
BM 652/653/654/ 655/656/657/658/659	<ul style="list-style-type: none"> EN Boot DE Manschette FR Manchon ES Retén PT Guarda-pó eixo RU Манжета 		650 528 0091	02.21871 
BM 652/653/654/655, BM 656/657/658/659	<ul style="list-style-type: none"> EN Rubber seal DE Gummimanschette FR Manchette en caoutchouc ES Marco antifaz de goma PT Guarda-pó eixo RU Резиновая манжета 		655 528 0182	02.21866 
BM 625, BM 645/646/647/648/649, BM 655/656/657/ 658/659	<ul style="list-style-type: none"> EN Boot DE Manschette FR Manchon ES Manguito PT Guarda-pó eixo RU Манжета 		620 520 0196	02.21849 
BM 645/646, 648/649, BM 652, 655/656, 658/659	<ul style="list-style-type: none"> EN Boot DE Manschette FR Manchon ES Retén PT Guarda-pó eixo RU Манжета 		655 520 0096	02.21851 
BM 387	<ul style="list-style-type: none"> EN Rubber bearing DE Gummilager FR Silentbloc ES Cojinete de goma PT Coxim RU Резиновая подушка 		000 528 0085	02.21869 

THE ORIGINAL NUMBERS OF THE VEHICLE MANUFACTURER MAY BE USED FOR COMPARISON PURPOSES ONLY AND MUST NOT BE MENTIONED ON INVOICES TO VEHICLE OWNERS.

Air FilterLuftfilter • Filtre à air • Filtro de Aire
Filtro de Ar • Воздушный фильтр

Application	Description	Details	Ref.	Erqo No.
BM 385/387/389, B M 645/646/647/ 648/649, BM 655/656, 658/659	<ul style="list-style-type: none">EN Rubber bufferDE GummipufferFR Tampon caoutchoucES Tope de gomaPT Coxim condutor arRU Резиновый буфер		001 987 6340	02.22407 

Application	Description	Details	Ref.	Erqo No.
BM 381/383/385/387, 389/391/395, BM 620/621/623/623	<ul style="list-style-type: none"> EN Stop light switch DE Bremslichtschalter FR Contacteur de stop ES Interruptor de luz de freno PT Interruptor, luz freio RU Выключатель сигнала 		000 545 5509	02.21967 
GM 712/713/714/715 BM 381/385/387/389, 393 BM 619/620/621/623, 624/625/645	<ul style="list-style-type: none"> EN Switch DE Schalter FR Commodo ES Interruptor PT Interruptor RU Включатель 	M 27 x 1 / M 12 x 1,5 	000 545 7909	02.21974 
GM 712/713/714/715 BM 381/385/387/389, 393 BM 619/620/621/623, 625/645	<ul style="list-style-type: none"> EN Switch DE Schalter FR Interrupteur ES Interruptor PT Interruptor RU Включатель 	M 27 x 1 / M 12 x 1 	001 545 2709	02.21982 
BM 381/383/385/387, 389/393/395 BM 616/617/619/620, 621/622/623/624, 625/645/646/647, 648/649/652/653, 654/655/656/657, 658/659	<ul style="list-style-type: none"> EN Stop light switch DE Bremslichtschalter FR Contacteur de stop ES Interruptor de luz de freno PT Interruptor, luz freio RU Выключатель сигнала торможения 	M 12 x 1 	000 545 6909	02.21972 
BM 381/383/385/387, 389/393/395	<ul style="list-style-type: none"> EN Switch DE Schalter FR Interrupteur ES Interruptor PT Interruptor trava cabine RU Выключатель 	1 +/-0,2 bar; M10 x 1 / M 24 x 1 	001 545 5314	02.21997 
BM 381/383/385/387, 389/393/395 BM 616/617/619/620, 621/622/623/624, 625/645/646/647, 648/649/652/653, 654/655/656/657, 658/659	<ul style="list-style-type: none"> EN Switch DE Schalter FR Commodo ES Interruptor PT Interruptor RU Включатель 	5,5 bar; M 12 x 1,5 / M 24 x 1 	000 545 5414	02.21993 

THE ORIGINAL NUMBERS OF THE VEHICLE MANUFACTURER MAY BE USED FOR COMPARISON PURPOSES ONLY AND MUST NOT BE MENTIONED ON INVOICES TO VEHICLE OWNERS.

Application	Description	Details	Ref.	Erqo No.
BM 381/383/385/387, 389/393/395 BM 616/617/619/620, 621/622/623/624, 625/645/646/647, 648/649/652/653, 654/655/656/657, 658/659	<ul style="list-style-type: none"> EN Switch DE Schalter FR Commodo ES Interruptor PT Interruptor RU Выключатель 	5,5+-0,2 bar; M12 x 1,5 / M 24x1	001 545 6814	02.21998 
BM 397	<ul style="list-style-type: none"> EN Switch DE Schalter FR Commodo ES Interruptor PT Interruptor RU Выключатель 	0,1 - 0,5 bar; M12 x 1,5 / M 27 x 1	003 545 9214	02.22005 
OM 441/442 LA, BM 381/383/385/387, 389/393/395 BM 616/617/619/620, 621/622/623/624, 625/645/646/647, 648/649/652/653, 654/655/656/657, 658/659	<ul style="list-style-type: none"> EN Start switch DE Startschalter FR Interrupteur de démarrage ES Interruptor de arranque PT Botão partida RU Выключатель стартера 		003 545 2314	02.22022 
BM 381/383/385/387, 389/393/395 BM 616/617/619/620, 621/622/623/624, 625/652/655	<ul style="list-style-type: none"> EN Switch DE Schalter FR Commodo ES Interruptor PT Interruptor RU Выключатель 	2,0-5,0 bar; M10 x 1 / M 27x1	000 545 5909	02.21969 
BM 381/383/385/387, 389/393/395, BM 616/619/621/624	<ul style="list-style-type: none"> EN Switch DE Schalter FR Commodo ES Interruptor PT Interruptor RU Выключатель 	1,0+- 0,2 bar; M10 x 1,0 / M 24 x 1	000 545 5214	02.21992 
BM 620/623/624	<ul style="list-style-type: none"> EN Switch DE Schalter FR Commodo ES Interruptor PT Interruptor RU Выключатель 	5,0+- 0,2 bar; M12 x 1,5 / M 24 x 1	000 545 7514	02.21994 

Application	Description	Details	Ref.	Erqo No.
GM 710/712/718/719	EN Switch DE Schalter FR Interrupteur ES Interruptor PT Interruptor RU Выключатель	M 18 x 1,5 / M 27 x 1	000 545 6106	02.21956 
				
GM 714/715	EN Switch DE Schalter FR Interrupteur ES Interruptor PT Interruptor RU Включатель	M 12 x 1 / M 27 x 1	001 545 1209	02.21978 
				
GM 714/715	EN Switch DE Schalter FR Interrupteur ES Interruptor PT Interruptor RU Включатель	M 20 x 1,5 / M 27 x 1	001 545 1309	02.21980 
				
BM 625	EN Switch DE Schalter FR Interrupteur ES Interruptor PT Interruptor RU Включатель	1 -1,4 bar; M 12 x 1,5 / M 27 x 1	000 545 5609	02.21968 
				
BM 381/383/385/387, 389/393/395 BM 616/617/619/620, 621/622/623/624, 625/645/646/647, 648/649/652/653, 654/655/656/657, 658/659	EN Impulse generator DE Impulsgeber FR Emetteur d'impulsions ES Generador de impulsos PT Sensor impulso RU Импульсный датчик		006 542 4617	02.21901 
				
BM 381/383/385/387, 389/393/395 BM 616/617/619/620, 621/622/623/624, 625	EN Steering column switch DE Lenkstockschalter FR Commodo ES Conmutador de la columna de dirección PT Chave seta RU Выключатель		005 545 5124	02.22014 
				

THE ORIGINAL NUMBERS OF THE VEHICLE MANUFACTURER MAY BE USED FOR COMPARISON PURPOSES ONLY AND MUST NOT BE MENTIONED ON INVOICES TO VEHICLE OWNERS.

1

Application	Description	Details	Ref.	Erqo No.
BM 616/617/619/620, 621/622/623/624, 625/645/646/647, 648/649	<ul style="list-style-type: none"> EN Steering column switch DE Lenkstockschalter FR Commodo ES Conmutador de la columna de dirección PT Chave seta RU Выключатель 		620 540 0045	02.21881 
BM 381/383/385/387, 389/393/395 BM 616/617/619/620, 621/622/623/624, 625	<ul style="list-style-type: none"> EN Steering column switch DE Lenkstockschalter FR Commodo ES Conmutador de la columna de dirección PT Chave seta RU Выключатель 		005 545 5224	02.22015 
BM 616/617/619/620, 621/622/623/624, 625/645/646/647, 648/649/652	<ul style="list-style-type: none"> EN Steering column switch DE Lenkstockschalter FR Commodo ES Conmutador de la columna de dirección PT Chave seta RU Выключатель 		620 540 0145	02.21882 
BM 625/652/653/654, 655/656/657/658, 659	<ul style="list-style-type: none"> EN Steering column switch DE Lenkstockschalter FR Commodo ES Conmutador de la columna de dirección PT Chave seta RU Выключатель 		655 540 0045	02.21883 
BM 625/652/653/654, 655/656/657/658, 659	<ul style="list-style-type: none"> EN Steering column switch DE Lenkstockschalter FR Commodo ES Conmutador de la columna de dirección PT Chave seta RU Выключатель 		655 540 0145	02.21884 

THE ORIGINAL NUMBERS OF THE VEHICLE MANUFACTURER MAY BE USED FOR COMPARISON PURPOSES ONLY AND MUST NOT BE MENTIONED ON INVOICES TO VEHICLE OWNERS.

Application	Description	Details	Ref.	Erqo No.
BM 616/617/619/620, 621/622/623/624, 625/645/646/647, 648/649/652/653, 654/655/656/657, 658/659	<ul style="list-style-type: none"> EN Battery cover DE Batteriedeckel FR Couvercle bac à batteries ES Tapa de la batería PT Tampa caixa bateria RU Крышка АКБ 		620 541 0303	02.21893 
NG/SK/MK	<ul style="list-style-type: none"> EN Strap, complete DE Haubenthaler, komplett FR Support de capot, complet ES Soporte del capó, completo PT Trava completa tampa bateria RU Навеска капота, в сборе 			02.23250 
NG/SK/MK	<ul style="list-style-type: none"> EN Rubber strap DE Gummihalterung FR Support en caoutchouc ES Sujeción de goma PT Trava borracha RU Резиновое крепление 		387 426 0040	02.21284 
BM 621/622/623/625, 652/653/654/655, 656/658/659	<ul style="list-style-type: none"> EN Locking handle DE Verschlußhebel FR Levier de fermeture ES Palanca de cierre PT Alavanca RU Рычаг 		000 988 0385	02.22411 

Application	Description	Details	Ref.	Erqo No.
BM 381/383/385/387, 389/393/395 BM 616/617/619/620, 621/622/623/624, 625/645/646/647, 648/649	<ul style="list-style-type: none"> EN Relay, warning turn signal DE Warnblinkgeber FR Relais, clignotant ES Transmisor, Luces intermitentes de emergencia PT Relé, interruptor pisca alerta RU Датчик, Аварийная сигнализация 		003 544 0632	02.21937 
				
BM 381/383/385/387, 389/393/395 BM 616/617/619/620, 621/622/623/624, 625/645/646/647, 648/649	<ul style="list-style-type: none"> EN Relay DE Relais FR Relais ES Relé PT Relé RU Реле 		022 545 2532	02.22017 
				
BM 381/383/385/387, 389/393/395 BM 616/617/619/620, 621/622/623/624, 625/645/646/647, 648/649/652/653, 654/655/656/657, 658/659	<ul style="list-style-type: none"> EN Relay DE Relais FR Relais ES Relé PT Relé RU Реле 	24V 20A	003 545 9605	02.21953 
				
BM 625/652/653/654, 655/656/657/658, 659	<ul style="list-style-type: none"> EN Relay DE Relais FR Relais ES Relé PT Relé RU Реле 	24V 20A	004 545 0605	02.21954 
				
12 BM 381/383/385/387, 389/393/395	<ul style="list-style-type: none"> EN Buzzer DE Summer FR Vibreur sonore ES Avisador acústico PT Alarme temperatura RU Шумовой сигнализатор 	24 V	000 542 1123	02.21923 
				

THE ORIGINAL NUMBERS OF THE VEHICLE MANUFACTURER MAY BE USED FOR COMPARISON PURPOSES ONLY AND MUST NOT BE MENTIONED ON INVOICES TO VEHICLE OWNERS.

Application	Description	Details	Ref.	Erqo No.
BM 381/383/385/387, 389/393/395 BM 616/617/619/620, 621/622/623/624, 625/645/646/647, 648/649/652/653, 654/655/656/657, 658/659	(EN) Horn (DE) Signalhorn (FR) Avertisseur sonore (ES) Bocina (PT) Buzina (RU) Звуковой сигнал	24V 335 Hz	004 542 6720	02.21922 



Application	Description	Details	Ref.	Erqo No.
BM 381/383/385/387, 389/393/395	<ul style="list-style-type: none"> EN Ignition switch DE Startschalter FR Contacteur de Neiman ES Interruptor de arranque PT Miolo chave ignição RU Выключатель стартера 		000 545 3013	02.21988 
BM 381/383/385/387, 389/393/395	<ul style="list-style-type: none"> EN Key DE Schlüssel FR Clé ES Llave PT Chave ignição RU Ключ 		000 545 1235	02.22018 
BM 381/383/385/387, 389/393/395, BM 616/617/619/620, 621/622/623/624, 625	<ul style="list-style-type: none"> EN Hazard warning switch, complete DE Wamblinkschalter, komplett FR Interrupteur feux de détresse, complet ES Interruptor de la luz intermitente, completo PT Interruptor pisca alerta, completo RU Выключатель, в сборе 		004 545 0224	02.22010 
BM 381/383/385/387, 389/393/395, BM 616/617/619/620, 621/622/623/624, 625	<ul style="list-style-type: none"> EN Hazard warning switch DE Wamblinkschalter FR Interrupteur feux de détresse ES Interruptor de la luz intermitente PT Interruptor pisca alerta RU Выключатель 		004 545 0224	02.22011 
12 BM 381/383/385/387, 389/393/395, BM 616/617/619/620, 621/622/623/624, 625	<ul style="list-style-type: none"> EN Botton, hazard warning switch DE Knopf, Warnblinkschalter FR Commodo, Interrupteur feux de détresse ES Botón, Interruptor de la luz intermitente PT Botão , Interruptor pisca alerta RU Кнопка выключателя 		000 545 3637	02.22019 

THE ORIGINAL NUMBERS OF THE VEHICLE MANUFACTURER MAY BE USED FOR COMPARISON PURPOSES ONLY AND MUST NOT BE MENTIONED ON INVOICES TO VEHICLE OWNERS.









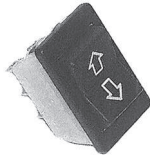

Application	Description	Details	Ref.	Erqo No.
OM 441/442 LA, BM 381/383/385/387, 389/393/395 BM 616/617/619/620, 621/622/623/624, 625/645/646/647, 648/649/652/653, 654/655/656/657, 658/659	EN Start switch DE Startschalter FR Interrupteur de démarrage ES Interruptor de arranque PT Botão partida RU Выключатель стартера		003 545 2314	02.22022 
BM 381/383/385/387, 389/393/395 BM 621	EN Start switch DE Startschalter FR Contacteur de démarrage ES Interruptor de arranque PT Interruptor, partida RU Выключатель стартера		001 545 4914	02.21996 
BM 616/617/619/620, 621/622/623/624, 625/645/646/647, 648/649	EN Light switch DE Lichtschalter FR Interrupteur éclairage ES Interruptor de luces PT Interruptor farol RU Выключатель освещения		000 545 5913	02.21990 
BM 652/653/654/655, 656/657/658/659	EN Light switch DE Lichtschalter FR Interrupteur de phare ES Interruptor de luces PT Interruptor farol RU Выключатель освещения		000 545 3704	02.21948 
BM 652/653/654/655, 656/657/658/659	EN Light switch DE Lichtschalter FR Interrupteur éclairage ES Interruptor de luces PT Interruptor luzes RU Выключатель освещения		000 545 6704	02.21950 

THE ORIGINAL NUMBERS OF THE VEHICLE MANUFACTURER MAY BE USED FOR COMPARISON PURPOSES ONLY AND MUST NOT BE MENTIONED ON INVOICES TO VEHICLE OWNERS.

Application	Description	Details	Ref.	Erqo No.
BM 652/653/654/655, 656/657/658/659	<ul style="list-style-type: none"> EN Knob DE Knopf FR Bouton interrupteur éclairage ES Botón PT Botão interruptor luz RU Кнопка 		202 545 0081	02.22020 
BM 381/383/385/387, 389/393/395 BM 616/617/619/620, 621/622/623/624, 625/645/646/647, 648/649/652/653, 654/655/656/657, 658/659	<ul style="list-style-type: none"> EN Bulb holder DE Lampensockel FR Douille ES Portalámparas PT Soquete lâmpada RU Цоколь лампы 		001 545 1815	02.22007 
BM 652/653/654/655, 656/657/658/659	<ul style="list-style-type: none"> EN Lamp socket DE Lampenfassung FR Douille de lampe ES Portalámparas PT Soquete lâmpada RU Патрон лампы 		655 544 0094	02.21947 
BM 390	<ul style="list-style-type: none"> EN Lens, turn signal DE Lichtscheibe, Blinker FR Symbole, clignotant ES Placa de luz, Intermitente PT Tampa RU Символ, указатель поворота 		000 545 1290	02.22023 
12 BM 390	<ul style="list-style-type: none"> EN Lens, Battery DE Lichtscheibe, Batterie FR Symbole, batterie ES Placa de luz, Bateria PT Indicador bateria RU Символ, Аккумулятор 		000 545 0190	02.22021 

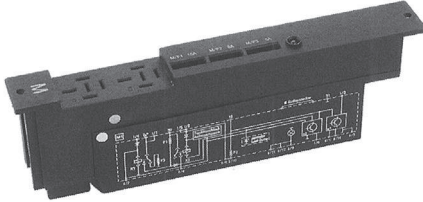

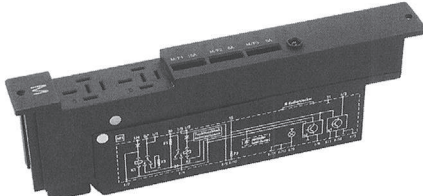





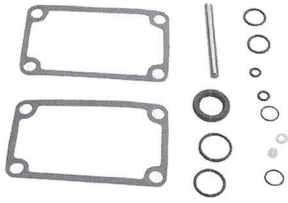

Application	Description	Details	Ref.	Erqo No.
BM 390	EN Lens, high beam DE Lichtscheibe, Fernlicht FR Symbole, feux de route ES Placa de luz, Luz de carretera PT Indicador luz alta RU Символ, Дальний свет		000 545 1190	02.22022 
BM 652/653/654/655, 656/657/658/659	EN Switch, heater DE Schalter, Gebläse FR Interrupteur, ventilateur ES Interruptor, soplador PT Interruptor, ventoinha RU Выключатель		667 545 0204	02.21951 
BM 381/383/385/387, 389/393/395 BM 616/617/619/620, 621/622/623/624, 625/645/646/647, 648/649/652/653, 654/655/656/657, 658/659	EN Switch DE Schalter FR Commodo ES Interruptor PT Interruptor RU Выключатель		002 545 6907	02.21959 
BM 381/383/385/387, 389/393/395 BM 616/617/619/620, 621/622/623/624, 625/645/646/647, 648/649/652/653, 654/655/656/657, 658/659	EN Switch DE Schalter FR Interrupteur ES Interruptor PT Interruptor RU Выключатель		002 545 7607	02.21960 
BM 381/383/385/387, 389/393/395 BM 616/617/619/620, 621/622/623/624, 625/645/646/647, 648/649/652/653, 654/655/656/657, 658/659	EN Switch DE Schalter FR Commodo ES Interruptor PT Interruptor RU Выключатель		002 545 4807	02.21958 
BM 620/621/622/623, 624/625	EN Switch, window lifter DE Schalter, Fensterheber FR Interrupteur, Lève-vitre ES Interruptor, Elevalunas PT Interruptor, regulador vidro RU Клавиша стеклоподъемника		001 545 8607	02.21957 

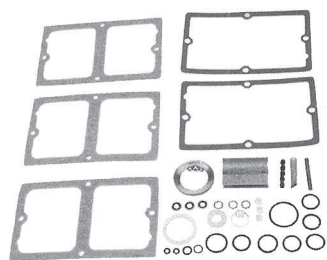

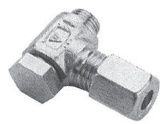



THE ORIGINAL NUMBERS OF THE VEHICLE MANUFACTURER MAY BE USED FOR COMPARISON PURPOSES ONLY AND MUST NOT BE MENTIONED ON INVOICES TO VEHICLE OWNERS.











Application	Description	Details	Ref.	Erqo No.
BM 620/621/622/623, 624/625	<ul style="list-style-type: none"> EN Switch DE Schalter FR Interrupteur ES Interruptor PT Interruptor RU Выключатель 		002 821 0651	02.22240 
BM 381/383/385/387, 389/393/395 BM 616/617/619/620, 621/622/623/624, 625/645/646/647, 648/649/652/653, 654/655/656/657, 658/659	<ul style="list-style-type: none"> EN Bulb holder DE Lampenfassung FR Douille ES Portalámparas PT Soquete RU Оправа 		000 545 1219	02.22008 
BM 381/383/385/387, 389/393/395 BM 616/617/619/620, 621/622/623/624, 625/645/646/647, 648/649/652/653, 654/655/656/657, 658/659	<ul style="list-style-type: none"> EN Instrument cluster DE Kombiinstrument FR Indicateur de tableau de bord ES Cluster PT Instrumento combinado RU Панель приборов 		003 540 9647	02.21886 
BM 625/645/646/647, 648/649/652/653, 654/655/656/657, 658/659	<ul style="list-style-type: none"> EN Module M DE Modul M FR Module M ES Modulo M PT Módulo motor M RU Модуль M 		000 543 9015	02.21927 
12 BM 625/652/653/654, 655/656/657/658, 659	<ul style="list-style-type: none"> EN Module W DE Modul W FR Module W ES Modulo W PT Módulo motor W RU Модуль W 		000 543 1015	02.21926 

THE ORIGINAL NUMBERS OF THE VEHICLE MANUFACTURER MAY BE USED FOR COMPARISON PURPOSES ONLY AND MUST NOT BE MENTIONED ON INVOICES TO VEHICLE OWNERS.









Application	Description	Details	Ref.	Erqo No.
BM 381/383/385/387, 389/393/395 BM 616/617/619/620, 621/622/623/624, 625/645/646/647, 648/649/652/653, 654/655/656/657, 658/659	<ul style="list-style-type: none"> EN Cab tilt pump DE Hydraulikpumpe FR Pompe de levage de cabine ES Bomba hidráulica, elevación de cabina PT Cilindro elevação cabine RU Гидравлический насос 		000 553 7901	02.22038 
BM 624/625/652/653, 654/655/656/657, 658/659	<ul style="list-style-type: none"> EN Cab tilt pump DE Hydraulikpumpe FR Pompe de levage de cabine ES Bomba hidráulica, elevación de cabina PT Cilindro elevação cabine RU Гидравлический насос 		000 553 8901	02.22039 
BM 625/652/653/654, 655/656/657/658, 659	<ul style="list-style-type: none"> EN Cab tilt pump DE Hydraulikpumpe FR Pompe de levage de cabine ES Bomba hidráulica, elevación de cabina PT Cilindro elevação cabine RU Гидравлический насос 		000 553 6901	02.22037 
BM 381/383/385/387, 389/393/395 BM 616/617/619/620, 621/622/623/624, 625/645/646/647, 648/649	<ul style="list-style-type: none"> EN Gasket kit DE Dichtsatz FR Kit de joints ES Juego de juntas PT Jogo junta RU Комплект уплотнителей 		000 550 2583	02.22033 
BM 381/383/385/387, 389/393/395 BM 616/617/619/620, 621/622/623/624, 625/645/646/647, 648/649/652/653, 654/655/656/657, 658/659	<ul style="list-style-type: none"> EN Gasket kit DE Dichtsatz FR Kit de joints ES Juego de juntas PT Jogo junta RU Комплект уплотнений 		000 550 2783	02.22034 



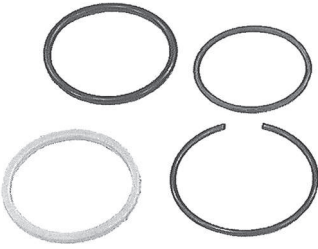

Application	Description	Details	Ref.	Erqo No.
BM 381/383/385/387, 389/393/395 BM 616/617/619/620, 621/622/623/624, 625/645/646/647, 648/649	<ul style="list-style-type: none"> EN Repair kit DE Reparatursatz FR Kit de réparation ES Kit de reparación PT Jogo reparo RU Ремонтный комплект 		000 550 0255	02.22030 
BM 616/617/619/620, 621/622/623/624, 625/645/646/647, 648/649/652/653, 654/655/656/657, 658/659	<ul style="list-style-type: none"> EN Repair kit DE Reparatursatz FR Kit de réparation ES Kit de reparación PT Jogo reparo RU Ремонтный комплект 		000 550 2355	02.22031 
BM 381/383/385/387, 389/393/395 BM 616/617/619/620, 621/622/623/624, 625/645/646/647, 648/649/652/653, 654/655/656/657, 658/659	<ul style="list-style-type: none"> EN Elbow adapter DE Anschlussnippel FR Filière de raccordement ES Casquillo roscado de empalme PT Conector RU Соединительный наконечник 		000 990 9268	02.22489 
BM 381/383/385/387, 389/393/395 BM 616/617/619/620, 621/622/623/624,	<ul style="list-style-type: none"> EN Cab tilt cylinder DE Kippzylinder FR Vérin levage de cabine ES Cilindro hidráulico elevación de cabina PT Cilindro bascular cabine RU Опрокидывающий цилиндр 		001 553 3605	02.22044 
BM 620, 621/622/623/624, 625/645/646/647, 648/649/652/653, 654/655/656/657, 658/659	<ul style="list-style-type: none"> EN Cab tilt cylinder DE Kippzylinder FR Vérin levage de cabine ES Cilindro hidráulico elevación de cabina PT Cilindro bascular cabine RU Опрокидывающий цилиндр 		001 553 4505	02.22048 





Application	Description	Details	Ref.	Erqo No.
BM 381/383/385/387, 389/393/395	<ul style="list-style-type: none"> EN Cab tilt cylinder DE Kippzylinder FR Cylindre à bascule ES Cilindro hidráulico elevación de cabina PT Cilindro bascular cabine RU Опрокидывающий цилиндр 		001 553 4605	02.22049 
BM 381/383/385/387, 389/393/395 BM 616/617/619/620, 621/622/623/624, 645/646/647/648, 649/652/653, 654/655/656/657, 658/659	<ul style="list-style-type: none"> EN Cab tilt cylinder DE Kippzylinder FR Cylindre à bascule ES Cilindro hidráulico elevación de cabina PT Cilindro bascular cabine RU Опрокидывающий цилиндр 		001 553 4205	02.22046 
BM 616/617/619/620, 621/622/623/624, 625/645/646/647, 648/649/652/653, 654/655/656/657, 658/659	<ul style="list-style-type: none"> EN Cab tilt cylinder DE Kippzylinder FR Cylindre à bascule ES Cilindro hidráulico elevación de cabina PT Cilindro bascular cabine RU Опрокидывающий цилиндр 		001 553 3505	02.22043 
BM 620/621, 622/623/624/625/645, 646/647/648/649/652, 653/654/655/656/657, 658/659	<ul style="list-style-type: none"> EN Cab tilt cylinder DE Kippzylinder FR Vérin levage de cabine ES Cilindro hidráulico elevación de cabina PT Cilindro bascular cabine RU Опрокидывающий цилиндр 		001 553 4705	02.22050 
BM 625/645/646/647, 648/649/652/653, 654/655/656/657, 658/659	<ul style="list-style-type: none"> EN Cab tilt cylinder DE Kippzylinder FR Vérin levage de cabine ES Cilindro hidráulico elevación de cabina PT Cilindro bascular cabine RU Опрокидывающий цилиндр 		001 553 2505	02.22042 

Application	Description	Details	Ref.	Erqo No.
BM 616/617/619/620, 621/622/623/624, 625/645/646/647, 648/649/652/653, 654/655/656/657, 658/659	<ul style="list-style-type: none"> EN Cab tilt cylinder DE Kippzylinder FR Vérin levage de cabine ES Cilindro hidráulico elevación de cabina PT Cilindro bascular cabine RU Опрокидывающий цилиндр 		001 553 4005	02.22045 
BM 655	<ul style="list-style-type: none"> EN Cab tilt cylinder DE Kabinenzylinder FR Vérin levage de cabine ES Cilindro hidráulico elevación de cabina PT Cilindro bascular cabine RU Опрокидывающий цилиндр 		001 553 4305	02.22047 
BM 381/383/385/387, 389/393/395 BM 616/617/619/620, 621/622/623/624, 625/645/646/647, 648/649	<ul style="list-style-type: none"> EN Repair kit DE Reparatursatz FR Kit de réparation ES Kit de reparación PT Jogo reparo RU Комплект уплотнителей 		001 553 4905	02.22051 
BM 381/383/385/387, 389/393/395 BM 616/617/619/620, 621/622/623/624, 625/645/646/647, 648/649/652/653, 654/655/656/657, 658/659	<ul style="list-style-type: none"> EN Repair kit DE Reparatursatz FR Kit de réparation ES Kit de reparación PT Jogo reparo RU Комплект уплотнителей 		000 550 1407	02.22027 
BM 381/383/385/387, 389/393/395 BM 620, 621/622/623/624, 625/645/646/647, 648/649/652/653, 654/655/656/657, 658/659	<ul style="list-style-type: none"> EN Repair kit DE Reparatursatz FR Kit de réparation ES Kit de reparación PT Jogo reparo RU Ремонтный комплект 		000 550 1507	02.22028 



THE ORIGINAL NUMBERS OF THE VEHICLE MANUFACTURER MAY BE USED FOR COMPARISON PURPOSES ONLY AND MUST NOT BE MENTIONED ON INVOICES TO VEHICLE OWNERS.

Application	Description	Details	Ref.	Erqo No.
BM 381/383/385/387, 389/393/395 BM 616/617/619/620, 621/622/623/624, 625/645/646/647, 648/649	<ul style="list-style-type: none"> EN Repair kit DE Reparatursatz FR Kit de réparation ES Kit de reparación PT Jogo reparo RU Ремонтный комплект 		000 550 0407	02.22025 
BM 620/621/622/623, 624/625/645/646, 647/648/649	<ul style="list-style-type: none"> EN Repair kit DE Reparatursatz FR Kit de réparation ES Kit de reparación PT Jogo reparo RU Ремонтный комплект 		000 550 0507	02.22026 
BM 620, 621/622/623/624, 625/645/646/647, 648/649/652/653, 654/655/656/657, 658/659	<ul style="list-style-type: none"> EN Repair kit DE Reparatursatz FR Kit de réparation ES Kit de reparación PT Jogo reparo RU Ремонтный комплект 		000 550 1607	02.22029 
BM 381/383/385/387, 389/393/395 BM 616/617/619/620, 621/622/623/624, 625/645/646/647, 648/649/652/653, 654/655/656/657, 658/659	<ul style="list-style-type: none"> EN Bushing DE Buchse FR Vague ES Casquillo PT Vucha RU Втулка 		620 891 0417	02.22299 

Application	Description	Details	Ref.	Erqo No.
BM 381/383/385/ 387/389, 393/395, BM 616/617, BM 620/621/622/ 623/624/625, BM 652	<ul style="list-style-type: none"> EN Hydraulic hose DE Hydraulikschlauch FR Tuyau hydraulique ES Latiguillo hidráulico PT Mangueira hidráulica RU Шланг гидросистемы 		387 553 0382	02.22056 
BM 616/617/619, BM 620/621/622/ 623/624/625, B M 645/646, 648/649, BM 652	<ul style="list-style-type: none"> EN Hydraulic hose DE Hydraulikschlauch FR Tuyau hydraulique ES Latiguillo hidráulico PT Mangueira hidráulica RU Шланг гидросистемы 		620 553 0382	02.22057 
BM 381/383/385/ 387/389, 393/395, BM 616/617/619, BM 620/621/622/ 623/624/625, BM 645/646, 648/649	<ul style="list-style-type: none"> EN Hydraulic hose DE Hydraulikschlauch FR Tuyau hydraulique ES Latiguillo hidráulico PT Mangueira hidráulica RU Шланг гидросистемы 	L: 308 mm	387 553 0182	02.22055 
BM 616/617/619, BM 620/621/622/ 623/624/625, BM 645/646/647/ 648/649, BM 652/653/654/ 655/656/657/658/659	<ul style="list-style-type: none"> EN Hydraulic hose DE Hydraulikschlauch FR Tuyau hydraulique ES Latiguillo hidráulico PT Mangueira hidráulica RU Шланг гидросистемы 		655 553 0582	02.22059 

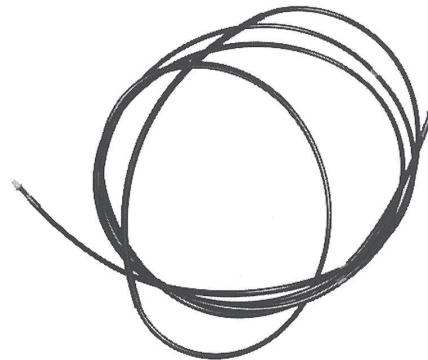
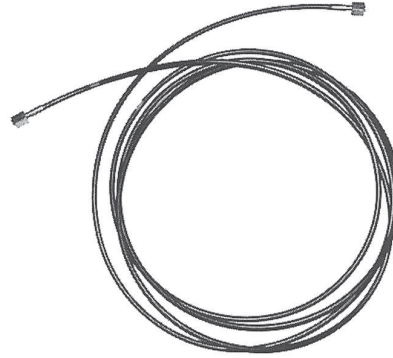
Application	Description	Details	Ref.	Erqo No.
BM 625, BM 645/646/647/ 648/649, BM 652/653/654/ 655/656/657/658/659	<ul style="list-style-type: none"> EN Hydraulic hose DE Hydraulikschlauch FR Tuyau hydraulique ES Latiguillo hidráulico PT Mangueira hidráulica RU Шланг гидросистемы 		655 553 0082	02.22058 
BM 381/383/385, BM 616/617/619, BM 620/621/622/ 623/624/625, BM 645, 648	<ul style="list-style-type: none"> EN Hydraulic hose DE Hydraulikschlauch FR Tuyau hydraulique ES Latiguillo hidráulico PT Mangueira hidráulica RU Шланг гидросистемы 		380 553 0082	02.22054 
BM 625, BM 652/653/ 654/655/656, 658/659	<ul style="list-style-type: none"> EN Hydraulic hose DE Hydraulikschlauch FR Tuyau hydraulique ES Latiguillo hidráulico PT Mangueira hidráulica RU Шланг гидросистемы 		656 550 0159	02.22032 
BM 381/383/ 385/387/389, 393/395, BM 616/617/619, BM 620/621/622/ 623/624/625	<ul style="list-style-type: none"> EN T-connector DE T-Stück FR Raccord en T ES Pieza T PT Conector - T RU Тройник 	6 mm	001 990 0170	02.22493 



Application	Description	Details	Ref.	Erqo No.
BM 620/621/622/ 623/624	<ul style="list-style-type: none"> EN T-connector DE T-Stück FR Raccord en T ES Pieza T PT Conector - T RU Тройник 	6 mm	000 990 3470	02.22492 
BM 381/383/385/387, 389 BM 616/617/619/620, 621/622/623/624, 625/645/646/647, 648/649/652/653, 654/655/656/657, 658/659	<ul style="list-style-type: none"> EN Elbow connector DE Winkelstutzen FR Raccord coudé ES Racor acodado PT Conexão cotovelo RU Угловой штуцер 	6 mm	001 990 9871	02.22494 



Application	Description	Details	Ref.	Erqo No.
NG/MK/SK	<ul style="list-style-type: none"> EN Socket wrench, bihexagon DE Steckschlüssel, zwölfkant FR Cie a douille, dodécagonal ES Llave para tuercas de ruedas, bihexágono PT Chave soquete, dodecágono RU Гаечный ключ, двенадцатигранник 	SW 30/32	000 581 3901	02.22062 
				
NG/MK/SK	<ul style="list-style-type: none"> EN Socket wrench, hexagon DE Steckschlüssel, sechskant FR Cie a douille, hexagonal ES Llave para tuercas de ruedas, hexágono PT Chave soquete, hexágono RU Гаечный ключ, шестигранник 	SW 30/32		02.22062 
				
NG/MK/SK	<ul style="list-style-type: none"> EN Socket wrench, bihexagon DE Steckschlüssel, zwölfkant FR Cie a douille, dodécagonal ES Llave para tuercas de ruedas, bihexágono PT Chave soquete, dodecágono RU Гаечный ключ, двенадцатигранник 	SW 32/33		02.22062 
				
NG/MK/SK	<ul style="list-style-type: none"> EN Socket wrench, hexagon DE Steckschlüssel, sechskant FR Cie a douille, hexagonal ES Llave para tuercas de ruedas, hexágono PT Chave soquete, hexágono RU Гаечный ключ, шестигранник 	SW 32/33		02.22062 
				
NG/MK/SK	<ul style="list-style-type: none"> EN Tire lever DE Montierhebel FR Demonte pneu ES Palanca de montaje de neumáticos PT Alavanca montar pneus RU Монтировка 		000 581 2158	02.22063 
				

THE ORIGINAL NUMBERS OF THE VEHICLE MANUFACTURER MAY BE USED FOR COMPARISON PURPOSES ONLY AND MUST NOT BE MENTIONED ON INVOICES TO VEHICLE OWNERS.

Application	Description	Details	Ref.	Erqo No.
NG/MK/SK	<ul style="list-style-type: none"> EN Silicone sealing compound, red DE Silikondichtmasse, rot FR Pâte à joints moteur, rouge ES Silicona impermeabilizante, roja PT Silicone, vermelho RU Силиконовый герметик, красного цвета 	310 ml		



NG/MK/SK	<ul style="list-style-type: none"> EN Tire inflat. hose DE Reifenfüllschlauch FR Flexible de gonflage ES Tubo flexible de inflado de neumáticos PT Tubo flexível, pneumático RU Шланг подкачки шин 	9 x 3,5 mm, 8 m	000 591 0404	02.22119
----------	--	-----------------	--------------	----------

















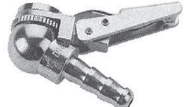

NG/MK/SK	<ul style="list-style-type: none"> EN Tire inf lat. hose DE Reifenfüllschlauch FR Flexible de gonflage ES Tubo flexible de inflado de neumáticos PT Tubo flexível, pneumático RU Шланг подкачки шин 	9 x 3,5 mm, 12 m	000 591 1304	02.22119
----------	---	------------------	--------------	----------

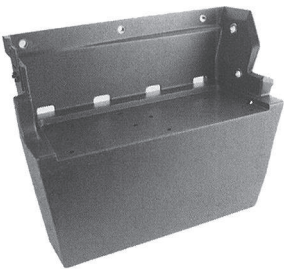

NG/MK/SK	<ul style="list-style-type: none"> EN Tire inflat. hose DE Reifenfüllschlauch FR Flexible de gonflage ES Tubo flexible de inflado de neumáticos PT Tubo flexível, pneumático RU Шланг подкачки шин 	9 x 3,5 mm, 15 m		02.22119
----------	--	------------------	--	----------



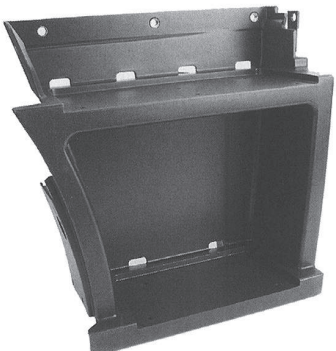







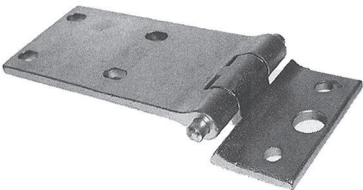

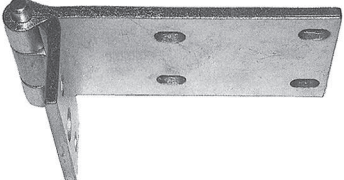
Application	Description	Details	Ref.	Erqo No.
NG/MK/SK	<ul style="list-style-type: none"> EN Air hose DE Luftschlauch FR Durite d'air ES Manguera de aire PT Mangueira RU Воздушный шланг 	9 x 3,5 mm, in lengths of 50 m		02.23250
				
NG/MK/SK	<ul style="list-style-type: none"> EN Wing nut DE Flügelmutter FR Ecrou d'aile ES Tuerca mariposa PT Conexão mangueira RU Гайка-барашек 			02.23251
				
NG/MK/SK	<ul style="list-style-type: none"> EN Sleeve DE Hülse FR Douille ES Manguito PT Luva espaçadora RU Гильза 	17 x 21 x 11,7		02.23252
				
NG/MK/SK	<ul style="list-style-type: none"> EN Air chuck DE Ventilstecknippel FR Embouts ES Voquilla encajable de válvula PT Engate ar RU Съемный клапанный ниппель 			02.23253
				

Application	Description	Details	Ref.	Erqo No.
BM 641/642	<ul style="list-style-type: none"> EN Step well cover, left DE Einstieg, links FR Emmarchement gauche ES Escalón, izquierdo PT Cobertura estribo, esquerdo RU Подножка, левая 		641 660 0001	02.22128 
BM 641/642	<ul style="list-style-type: none"> EN Step well cover, right DE Einstieg, rechts FR Emmarchement droit ES Escalón, derecho PT Cobertura estribo, direito RU Подножка, правая 		641 660 0101	02.22129 
BM 641/642/649	<ul style="list-style-type: none"> EN Step well cover, left DE Einstieg, links FR Emmarchement gauche ES Escalón, izquierdo PT Cobertura estribo, esquerdo RU Подножка, левая 		649 660 0006	02.22130 
BM 641/642/649	<ul style="list-style-type: none"> EN Step well cover, right DE Einstieg, rechts FR Emmarchement droit ES Escalón, derecho PT Cobertura estribo, direito RU Подножка, правая 		649 660 0106	02.22131 

Sample

Application	Description	Details	Ref.	Erqo No.
BM 381/383/385/387	<ul style="list-style-type: none"> EN Sealing frame, windscreen DE Dichtrahmen, Windschutzscheibe FR Joint d'étanchéité, pare-brise ES Marco de estanqueidad, Parabrisas PT Guarnição, pára-brisa RU Уплотняющая рамка, лобовое стекло 		381 671 0020	02.22133 
BM 641/642	<ul style="list-style-type: none"> EN Sealing frame, windscreen DE Dichtrahmen, Windschutzscheibe FR Joint d'étanchéité, pare-brise ES Marco de estanqueidad, Parabrisas PT Guarnição, pára-brisa RU Уплотняющая рамка, лобовое стекло 		381 670 0039	02.22132 
BM 381/383/385/387	<ul style="list-style-type: none"> EN Sealing frame, rear window DE Dichtrahmen, Rückwandfenster FR Joint d'étanchéité, vitre arrière ES Marco de estanqueidad, Ventanilla trasera PT Guarnição, janela traseira RU Уплотняющая рамка, заднее окно 		381 678 0020	02.22136 
BM 381/383085/387/389, BM 649	<ul style="list-style-type: none"> EN Sealing frame, side window DE Dichtrahmen, Seitenfenster FR Joint d'étanchéité, vitre ES Marco de estanqueidad, Ventanilla lateral PT Guarnição, janela lateral RU Уплотняющая рамка, боковое окно 		381 674 0220	02.22135 







Application	Description	Details	Ref.	Erqo No.
BM 381/383/385/387, 389/641/642/649	<ul style="list-style-type: none"> EN Hinge, top DE Scharnier, oben FR Charnière, haut ES Bisagra, superior PT Dobradiça, superior RU Шарнир, верхн. 		641 720 0637	02.22149 
BM 381/383/385/387, 389/641/642/649	<ul style="list-style-type: none"> EN Hinge, bottom DE Scharnier, unten FR Charnière, bas ES Bisagra, inferior PT Dobradiça, inferior RU Шарнир, нижн. 		641 720 0737	02.22150 
BM 381/383/385/387, 389/641/642/649	<ul style="list-style-type: none"> EN Repair kit DE Reparatursatz FR Kit de réparation ES Kit de reparación PT Jogo reparo RU Ремонтный комплект 			02.23383 
BM 381/383/385/387, 389/641/642/649	<ul style="list-style-type: none"> EN Bushing included DE Buchse enthalten FR Bague compris ES Casquillo incluido PT Bucha incluído na RU Втулка включече 		000 992 4005	02.22533 
BM 381/383/385/387, 389/641/642/649	<ul style="list-style-type: none"> EN Hinge pin included DE Scharnierbolzen enthalten FR Axe de charnière compris ES Perno de bisagra incluido PT Pino dobradiça incluído na RU Шарнирный болт включено 		381 723 0152	02.22160 





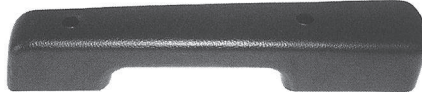

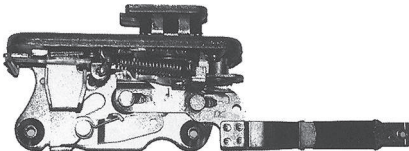

THE ORIGINAL NUMBERS OF THE VEHICLE MANUFACTURER MAY BE USED FOR COMPARISON PURPOSES ONLY AND MUST NOT BE MENTIONED ON INVOICES TO VEHICLE OWNERS.

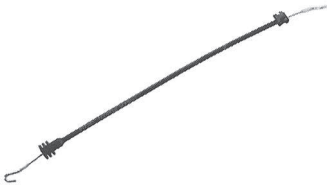
Application	Description	Details	Ref.	Erqo No.
BM 381/383/385/387, 389/641/642/649	<ul style="list-style-type: none"> EN Door stop DE Türhalter FR Tirant de porte ES Sujetapuertas PT Limitador porta RU Ограничитель хода двери 		000 720 0616	02.22145 
BM 381/383/385/387, 389	<ul style="list-style-type: none"> EN Window regulator, left DE Fensterheber, links FR Lève-vitre, gauche ES Elevalunas, izquierdo PT Máquina vidro, esquerdo RU Стеклоподъемник, лев. 		381 725 0002	02.22163 
BM 381/383/385/387, 389	<ul style="list-style-type: none"> EN Window regulator, right DE Fensterheber, rechts FR Lève-vitre, droit ES Elevalunas, derecho PT Máquina vidro, direito RU Стеклоподъемник, прав. 		381 725 0102	02.22164 
BM 641/642	<ul style="list-style-type: none"> EN Window regulator, left DE Fensterheber, links FR Lève-vitre, gauche ES Elevalunas, izquierdo PT Máquina vidro, esquerdo RU Стеклоподъемник, лев. 		641 720 0246	02.22151 
BM 641/642	<ul style="list-style-type: none"> EN Window regulator, right DE Fensterheber, rechts FR Lève-vitre, droit ES Elevalunas, derecho PT Máquina vidro, direito RU Стеклоподъемник, прав. 		641 720 0346	02.22152 

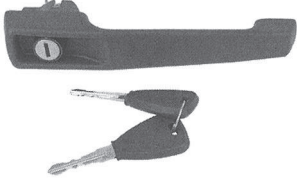
THE ORIGINAL NUMBERS OF THE VEHICLE MANUFACTURER MAY BE USED FOR COMPARISON PURPOSES ONLY AND MUST NOT BE MENTIONED ON INVOICES TO VEHICLE OWNERS.

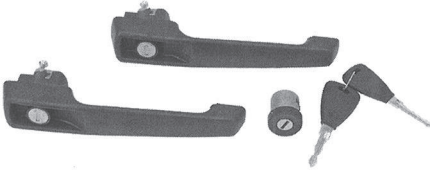
Application	Description	Details	Ref.	Erqo No.
BM 381/383/385/387, 389/393	<ul style="list-style-type: none"> EN Window guide DE Führungsschiene FR Glissière de vitre ES Riel guía PT Canaleta vidro janela RU Направляющая шина 		673 725 0001	02.22162 
BM 381/383/385/387, 389	<ul style="list-style-type: none"> EN Handle, complete DE Fensterkurbel, komplett FR Poignée, complet ES Manivela elevavinas, completo PT Maçaneta, completo RU Ручка стеклоподъемника, в сборе 			02.22167 
BM 381/383/385/387, 389	<ul style="list-style-type: none"> EN Handle DE Fensterkurbel FR Poignée ES Manivela PT Maçaneta RU Ручка стеклоподъемника 		381 725 0060	02.22167 
BM 381/383/385/387, 389	<ul style="list-style-type: none"> EN Rose DE Rosette FR Roue ES Roseta PT Rodizio maçaneta porta RU Розетка 		381 725 0043	02.22166 
BM 641/642/649	<ul style="list-style-type: none"> EN Handle DE Fensterkurbel FR Poignée ES Manivela elevavinas PT Maçaneta RU Ручка стеклоподъемника 		673 760 0002	02.22180 



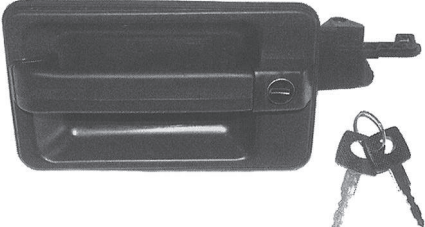



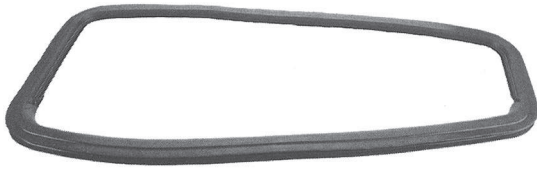

Application	Description	Details	Ref.	Erqo No.
BM 641/642/649	EN Arm rest, left DE Armlehne, links FR Accoudoir, gauche ES Reposabrazos, izquierdo PT Descanso braço, esquerdo RU Подлокотник, лев.		641 720 0095	02.22155 
BM 641/642/649	EN Arm rest, right DE Armlehne, rechts FR Accoudoir, droit ES Reposabrazos, derecho PT Descanso braço, direito RU Подлокотник, прав		641 720 0195	02.22156 
BM 381/383/385/387, 389	EN Door handle, inner DE Türgriff, innen FR Poignée de portière, interne ES Tirador de puerta, interior PT Maçaneta porta, interna RU Ручка двери, внутр.		381 760 0059	02.22182 
BM 381/383/385/387, 389, BM 641/642	EN Lock, left DE Schloss, links FR Serrure, gauche ES Cerradura, izquierda PT Fechadura esquerda RU Замок, лев.		381 723 0201	02.22157 
BM 381/383/385/387, 389, BM 641/642	EN Lock, right DE Schloss, rechts FR Serrure, droite ES Cerradura, derecha PT Fechadura direita RU Замок, прав.		381 723 0301	02.22158 
BM 381/383/385/387, 389	EN Interior handle DE Innenbetätigung FR Poignée intérieure ES Mando interior PT Maçaneta interna RU Внутреннее управление		381 766 0043	02.22187 

Application	Description	Details	Ref.	Erqo No.
BM 641/642/649	<ul style="list-style-type: none"> EN Control cable DE Zugkabel FR Câble ES Cable de tracción PT Cabo maçaneta interna RU Кабель тяги 	L: 278 mm	641 760 004	02.22181 
				
BM 381/383/385/387, 389	<ul style="list-style-type: none"> EN Door handle, plastic DE Türgriff, Kunststoff FR Poignée de portière, plastique ES Tirador de puerta, plástico PT Maçaneta porta, plástico RU Рукоятка двери, Пластик 		670 760 0159	02.22185 
				
BM 385/387/389	<ul style="list-style-type: none"> EN Lock kit, plastic DE Schließsatz, Kunststoff FR Kit de barillet, plastique ES Juego de cerraduras, plástico PT Jogo maçaneta porta, plástico RU Ключевой гарнитур, Пластик 		381 893 0603	02.22314 
				
BM 641/642/649	<ul style="list-style-type: none"> EN Door handle, left DE Türgriff, links FR Poignée de portière, gauche ES Tirador de puerta, izquierdo PT Maçaneta porta, esquerda RU Рукоятка двери, лев. 		641 760 0259	02.22183 
				
BM 641/642/649	<ul style="list-style-type: none"> EN Door handle, right DE Türgriff, rechts FR Poignée de portière, droit ES Tirador de puerta, derecho PT Maçaneta porta, direita RU Рукоятка двери, прав. 		641 760 0359	02.22184 
				

THE ORIGINAL NUMBERS OF THE VEHICLE MANUFACTURER MAY BE USED FOR COMPARISON PURPOSES ONLY AND MUST NOT BE MENTIONED ON INVOICES TO VEHICLE OWNERS.

Application	Description	Details	Ref.	Erqo No.
BM 641/642/649	<ul style="list-style-type: none"> EN Handle DE Hebel FR Poignée ES Palanca PT Maçaneta interna RU Рычаг 		641 723 0088	02.22161 
BM 381/383/385/387/389	<ul style="list-style-type: none"> EN Sealing frame, side window, left DE Dichtrahmen, Seitenfenster, links FR Joint d'étanchéité, vitre, gauche ES Marco de estanqueidad, ventanilla lateral, izquierda PT Guarnição quebra-vento, esquerda RU Уплотняющая рамка, левый 		381 725 0466	02.22168 
BM 381/383/385/387/389	<ul style="list-style-type: none"> EN Sealing frame, side window, right DE Dichtrahmen, Seitenfenster, rechts FR Joint d'étanchéité, vitre, droite ES Marco de estanqueidad, ventanilla lateral, derecha PT Guarnição quebra-vento, direita RU Уплотняющая рамка, правый 		381 725 0566	02.22169 
BM 381/383/385/387, 389/641/642/649	<ul style="list-style-type: none"> EN Handle, side window, left DE Griff, Seitenfenster, links FR Poignée, Fenêtre latérale gauche ES Manivela, ventanilla lateral, izquierda PT Trava quebra-vento, esquerda RU Рукоятка, Боковое окно, левое 		381 725 0279	02.22170 
BM 381/383/385/387, 389/641/642/649	<ul style="list-style-type: none"> EN Handle, side window, right DE Griff, Seitenfenster, rechts FR Poignée, Fenêtre latérale droite ES Manivela, ventanilla lateral, derecha PT Trava quebra-vento, direita RU Рукоятка, Боковое окно, правое 		381 725 0379	02.22171 

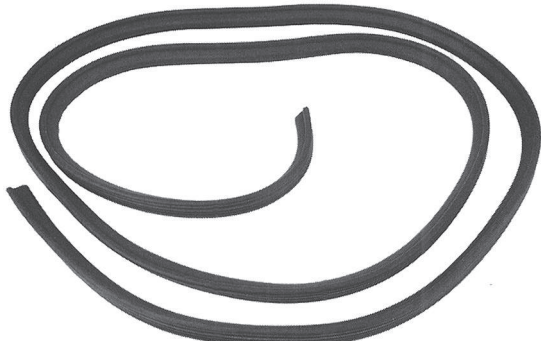
THE ORIGINAL NUMBERS OF THE VEHICLE MANUFACTURER MAY BE USED FOR COMPARISON PURPOSES ONLY AND MUST NOT BE MENTIONED ON INVOICES TO VEHICLE OWNERS.

Application	Description	Details	Ref.	Erqo No.
BM 381/383/385/387 389	<ul style="list-style-type: none"> EN Window frame DE Fensterrahmen FR Cadre de fenêtre ES Marco de ventanilla PT Moldura janela RU Рама окна 		381 725 0139	02.22165 
BM 381/383/385/387/389	<ul style="list-style-type: none"> EN Sealing strip, side window DE Dichtleiste, Seitenfenster FR Kit de joints, vitre latérale ES Lámina selladura, ventana lateral PT Guarnição, janela lateral RU Уплотнительная пластина 		001 987 4257	02.22409 
BM 381/83/85/387/389, BM 649	<ul style="list-style-type: none"> EN Sealing strip, door window DE Dichtleiste, Türfenster FR Kit de joints, vitre de portière ES Lámina selladura, ventana de puerta PT Guarnição janela RU Уплотнительная пластина 		309 673 0031	02.22134 
BM 381/383/385/387/389	<ul style="list-style-type: none"> EN Sealing frame, door DE Dichtrahmen, Tür FR Joint d'étanchéité, portière ES Marco sellador, Puerta PT Guarnição, porta RU Уплотняющая рамка, дверь 		673 697 0098	02.22143 

Application	Description	Details	Ref.	Erqo No.
BM 641/642/649	<ul style="list-style-type: none"> EN Door trim, left DE Türverkleidung, links FR Revêtement porte, gauche ES Panel de puerta, izquierdo PT Revestimento porta, esquerdo RU Обшивка двери, лев. 		641 720 1171	02.22153 

BM
641/642/649









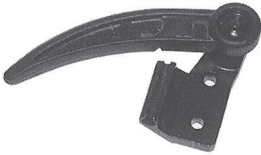

- EN Door trim, right
- DE Türverkleidung, rechts
- FR Revêtement porte, droit
- ES Panel de puerta, derecho
- PT Revestimento porta, direito
- RU Обшивка двери, прав.









641 720 1271









02.22154

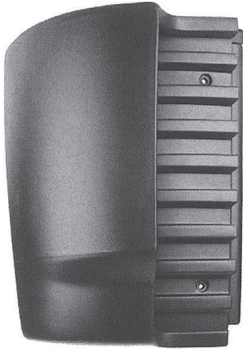

Application	Description	Details	Ref.	Erqo No.
BM 641/642	<ul style="list-style-type: none"> EN Front grill DE Kühlergrill FR Grille ES Parrilla delantera PT Grade frontal RU Решетка радиатора 		641 750 1009	02.22172 
BM 649	<ul style="list-style-type: none"> EN Front grill DE Frontgrill FR Calandre ES Parrilla delantera PT Grade frontal RU Решетка радиатора 		649 750 0118	02.22173 
BM 381/383/385/387, 389	<ul style="list-style-type: none"> EN Hood opener DE Haubenöffner FR Ouverture de capot ES Abre capó PT Puxador RU Устройство открывания капота 		970 310 0173	02.20792 
BM 381/383/385/387, 389	<ul style="list-style-type: none"> EN Hood lock DE Haubenverschluss FR Fermeture capot ES Cierre del capó PT Fechadura RU Замок капота 		000 750 0184	02.22176 
BM 641/642/649	<ul style="list-style-type: none"> EN Handle DE Griff FR Poignée ES Empuñadura PT Puxador trava capó RU Рукоятка 		641 750 0093	02.22178 
BM 641/642/649	<ul style="list-style-type: none"> EN Hood lock DE Haubenverschluss FR Fermeture capot ES Cierre del capó PT Fechadura capó RU Замок капота 		000 750 0484	02.22177 

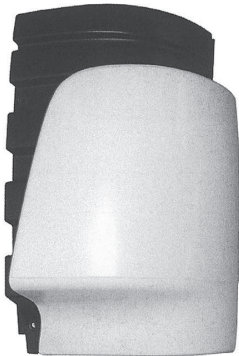

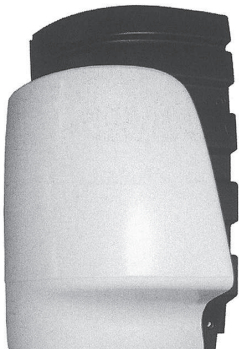



Application	Description	Details	Ref.	Erqo No.
BM 641/642/649	<ul style="list-style-type: none"> EN Bolt DE Bolzen FR Axe ES Bulón PT Parafuso RU Болт 		000 991 0912	02.22513 
				
BM 641/642, 649	<ul style="list-style-type: none"> EN Rubber buffer DE Gummipuffer FR Silentbloc ES Tope de goma PT Coxim RU Резиновый буфер 		641 752 0096	02.22179 
				
BM 381/383/385 chassis 697667 -- 4280304	<ul style="list-style-type: none"> EN Wire DE Zugseil FR Câble ES Cable de tracción PT Cabo RU Тяговый трос 	L: 800 mm	381 830 0131	02.22257 
				
BM 381/383/385/387 chassis 4280305 -	<ul style="list-style-type: none"> EN Wire DE Zugseil FR Câble ES Cable de tracción PT Cabo RU Тяговый трос 	L: 990 mm	381 830 0231	02.22258 
				
BM 389	<ul style="list-style-type: none"> EN Wire DE Zugseil FR Câble ES Cable de tracción PT Cabo RU Тяговый трос 	L: 1170 mm	389 830 0031	02.22259 
				

Application	Description	Details	Ref.	Erqo No.
BM 641/642	<ul style="list-style-type: none"> EN Lock wire DE Verriegelungszug FR Câble de verrouillage ES Cable de bloqueo PT Cabo RU Запорная тяга 	L: 1956 mm	641 750 0059	02.22174 
				
BM 649	<ul style="list-style-type: none"> EN Lock wire DE Verriegelungszug FR Câble de verrouillage ES Cable de bloqueo PT Cabo RU Запорная тяга 	L: 2100 mm	649 750 0159	02.22175 
				
BM 641/642/649	<ul style="list-style-type: none"> EN Gas spring DE Gasfeder FR Vérin à gaz ES Suspensión por gas PT Amortecedor RU Пневматический упругий элемент 		000 980 9064	02.22319 
				
BM 641/642/649	<ul style="list-style-type: none"> EN Air deflector, left DE Windabweiser, links FR Déflecteur, gauche ES Deflector de aire, izquierdo PT Defletor ar, esquerdo RU Обтекатель, лев. 		641 620 0036	02.22120 
				

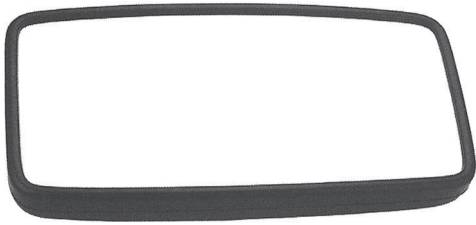



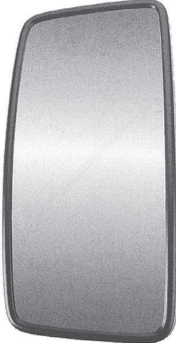

Application	Description	Details	Ref.	Erqo No.
BM 641/642/649	<ul style="list-style-type: none"> EN Air deflector, right DE Windabweiser, rechts FR Déflecteur, droite ES Deflector de aire, derecho PT Defletor ar, direito RU Обтекатель, прав. 		641 620 0136	02.22121 
BM 397	<ul style="list-style-type: none"> EN Spoiler DE Spoiler FR Spoiler ES Spoiler delantero PT Spoiler dianteiro RU Спойлер 		649 880 0136	02.22273 
BM 649	<ul style="list-style-type: none"> EN Cabin edge, left DE Kabinenecke, links FR Angle de cabine, gauche ES Deflector de aire, izquierdo PT Defletor, esquerdo RU Угол кабины, лев. 		649 620 0136	02.22125 
BM 649	<ul style="list-style-type: none"> EN Cabin edge, right DE Kabinenecke, rechts FR Angle de cabine, droite ES Deflector de aire, derecho PT Defletor, direito RU Угол кабины, прав. 		649 620 0236	02.22126 

THE ORIGINAL NUMBERS OF THE VEHICLE MANUFACTURER MAY BE USED FOR COMPARISON PURPOSES ONLY AND MUST NOT BE MENTIONED ON INVOICES TO VEHICLE OWNERS.

Application	Description	Details	Ref.	Erqo No.
BM 641/642	<ul style="list-style-type: none"> EN Cabin corner, left DE Kabinenecke, links FR Angle de cabine, gauche ES Deflector de aire, izquierdo PT Defletor, esquerdo RU Угол кабины, лев. 		641 620 1436	02.22123 
BM 641/642	<ul style="list-style-type: none"> EN Cabin corner, right DE Kabinenecke, rechts FR Angle de cabine, droite ES Deflector de aire, derecho PT Defletor, direito RU Угол кабины, прав. 		641 620 1536	02.22124 

Application	Description	Details	Ref.	Erqo No.
BM 641/642/649	<ul style="list-style-type: none"> EN Main mirror DE Hauptspiegel FR Rétroviseur principal ES Espejo principal PT Retrovisor principal RU Основное зеркало 	1800 mm	641 810 0016	02.22196 
				
BM 641/642/649	<ul style="list-style-type: none"> EN Mirror glass, main mirror DE Spiegelglas, Hauptspiegel FR Glace de rétroviseur principal ES Cristal de espejo principal PT Vidro espelho principal RU Зеркальное стекло 	1800 mm	001 811 8533	02.22213 
				
BM 381/383/385/387, 389, BM 641/642/649	<ul style="list-style-type: none"> EN Main mirror, heated DE Hauptspiegel, beheizt FR Rétroviseur principal, chauffant ES Espejo principal, calefactado PT Retrovisor principal, calefacao RU Основное зеркало, обогреваемое 	1800 mm	641 810 0116	02.22197 
				
BM 641/642/649	<ul style="list-style-type: none"> EN Main mirror, heated DE Hauptspiegel, beheizt FR Rétroviseur principal, chauffant ES Espejo principal, calefactado PT Retrovisor principal, calefacao RU Основное зеркало, обогреваемое 	1800 mm	641 810 4216	02.22198 
				

THE ORIGINAL NUMBERS OF THE VEHICLE MANUFACTURER MAY BE USED FOR COMPARISON PURPOSES ONLY AND MUST NOT BE MENTIONED ON INVOICES TO VEHICLE OWNERS.

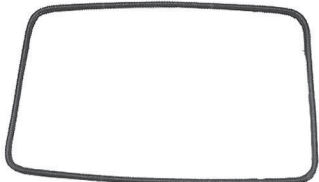
Application	Description	Details	Ref.	Erqo No.
BM 641/642/649	<ul style="list-style-type: none"> EN Mirror glass, main mirror DE Spiegelglas, Hauptspiegel FR Glace de rétroviseur principal ES Cristal de espejo principal PT Vidro espelho principal RU Зеркальное стекло 	1800 mm	000 811 8433	02.22209 
				
BM 641/642/649	<ul style="list-style-type: none"> EN Mirror glass, main mirror DE Spiegelglas, Hauptspiegel FR Glace de rétroviseur principal ES Cristal de espejo principal PT Vidro espelho principal RU Зеркальное стекло 	1800 mm	001 811 8633	02.22214 
				
BM 641/642/649	<ul style="list-style-type: none"> EN Main mirror, heated, electrical DE Hauptspiegel, beheizt, elektrisch FR Rétroviseur principal, chauffant, électrique ES Espejo principal, calefactado, eléctrico PT Retrovisor externo, calefacao, eléctrico RU Основное зеркало, обогреваемое, с электроприводом 	1800 mm	641 810 4416	02.22199 
				
BM 381/383/385/387, 389	<ul style="list-style-type: none"> EN Main mirror DE Hauptspiegel FR Rétroviseur principal ES Espejo principal PT Retrovisor principal RU Основное зеркало 	2000 mm	314 811 0330	02.22205 
				

Application	Description	Details	Ref.	Erqo No.
BM 381/383/385/387, 389	<ul style="list-style-type: none"> EN Mirror glass, main mirror DE Spiegelglas, Hauptspiegel FR Glace de rétroviseur principal ES Cristal de espejo principal PT Vidro espelho principal RU Зеркальное стекло 	2000 mm	000 811 1333	02.22206 

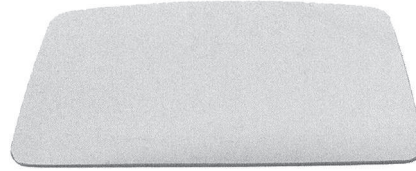

BM 381/385	<ul style="list-style-type: none"> EN Mirror arm DE Spiegelarm FR Bras de rétroviseur ES Soporte retrovisor PT Braço retrovisor RU Консоль зеркала 		381 810 0814	02.22190 
---------------	--	--	--------------	---











BM 641/642	<ul style="list-style-type: none"> EN Mirror bracket, left DE Spiegelarm, links FR Support de rétroviseur, gauche ES Soporte, izquierdo PT Soporte retrovisor, esquerdo RU Консоль зеркала, лев. 		641 810 1214	02.22192 
---------------	--	--	--------------	---





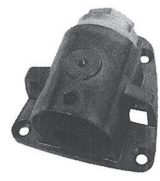

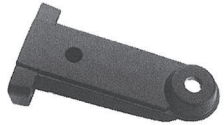

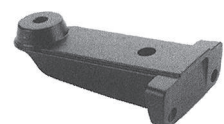
BM 641/642	<ul style="list-style-type: none"> EN Mirror arm, right DE Spiegelarm, rechts FR Bras de rétroviseur, droit ES Soporte del espejo, derecho PT Braço retrovisor, direito RU Кронштейн зеркала, прав. 		641 810 1114	02.22191 
---------------	---	--	--------------	---

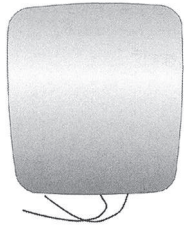

Sample

Application	Description	Details	Ref.	Erqo No.
BM 641/642	<ul style="list-style-type: none"> EN Mirror arm, left, special edition DE Spiegelarm, links, Sonderausführung FR Support de rétroviseur, gauche ES Soporte del espejo, izquierdo PT Braço retrovisor, esquerdo RU Консоль зеркала, лев. 	SA 53 272/52/75	641 810 1314	02.22193 
				Sample
BM 641/642	<ul style="list-style-type: none"> EN Mirror arm, right, special edition DE Spiegelarm, rechts, Sonderausführung FR Support de rétroviseur, droit ES Soporte del espejo, derecho PT Braço retrovisor, direito RU Кронштейн зеркала, прав. 	SA 53 272/52/75	641 810 1414	02.22194 
				Sample
BM 385/387/389, BM 641/642/649	<ul style="list-style-type: none"> EN Mirror bracket, bottom DE Spiegelhalter, unten FR Support de rétroviseur, inférieur ES Soporte del espejo, inferior PT Mancaí, inferior RU Кронштейн зеркала, нижн. 		641 810 0012	02.22188 
				
BM 641/642/649	<ul style="list-style-type: none"> EN Mirror bracket, upper DE Spiegelhalter, oben FR Support de rétroviseur, supérieur ES Soporte del espejo, superior PT Mancaí, superior RU Кронштейн зеркала, верхн. 		641 811 0226	02.22203 
				
BM 641/642/649	<ul style="list-style-type: none"> EN Mirror bracket, upper DE Spiegelhalter, oben FR Support de rétroviseur, supérieur ES Soporte del espejo, superior PT Mancaí, superior RU Кронштейн зеркала, верхн. 		641 811 0326	02.22204 
				

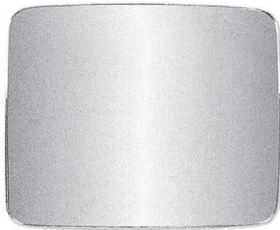
Application	Description	Details	Ref.	Erqo No.
BM 385/387, BM 641	<ul style="list-style-type: none"> EN Wide view mirror, heated DE Weitwinkelspiegel, beheizt FR Rétroviseur d'angle, chauffant ES Espejo gran angular, calefactado PT Retrovisor convexo, calefacao RU Панорамное зеркало, обогреваемое 	400 mm	673 810 3816	02.22202 
				
BM 385/387, BM 641	<ul style="list-style-type: none"> EN Mirror glass, wide view mirror, heated DE Spiegelglas, Weitwinkelspiegel, beheizt FR Glace de rétroviseur, rétroviseur d'angle, chauffant ES Cristal de espejo gran angular, calefactado PT Vidro espelho, retrovisor convexo, calefacao RU Зеркальное стекло, Панорамное зеркало, обогреваемое 	400 mm	001 811 8033	02.22212 
				
BM 641/642/649	<ul style="list-style-type: none"> EN Wide angle mirror, heated DE Weitwinkelspiegel, beheizt FR Rétroviseur d'angle, chauffant ES Espejo retrovisor, calefactado PT Retrovisor convexo, calefacao RU Панорамное зеркало, обогреваемое 	400 mm	641 810 4616	02.22200 
				
BM 641/642/649	<ul style="list-style-type: none"> EN Mirror glass, wide view mirror, heated DE Spiegelglas, Weitwinkelspiegel, beheizt FR Glace de rétroviseur, rétroviseur d'angle, chauffant ES Cristal de espejo gran angular, calefactado PT Vidro espelho, retrovisor convexo, calefacao RU Зеркальное стекло, Панорамное зеркало, обогреваемое 	400 mm	000 811 8533	02.22210 
				

Application	Description	Details	Ref.	Erqo No.
Cab 641,642,649	<ul style="list-style-type: none"> EN Kerb observation mirror DE Rampenspiegel FR Miroir d'accostage ES Espejo de rampa PT Retrovisor superior RU Фиксатор 	400 mm	641 810 6316	02.22201 



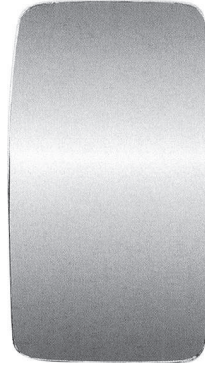

BM 641/642/649	<ul style="list-style-type: none"> EN Mirror glass, kerb observation mirror DE Spiegelglas, Rampenspiegel FR Glace de rétroviseur, miroir d'accostage ES Cristal de espejo, espejo de rampa PT Vidro espelho retrovisor, retrovisor superior RU Зеркальное стекло, Фиксатор 	400 mm	000 811 8633	02.22211 
-------------------	---	--------	--------------	--

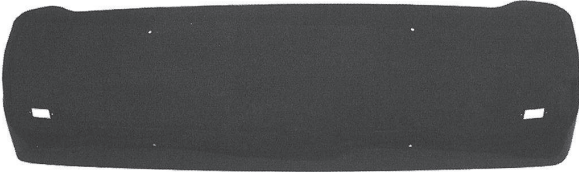

Sun Visor

Sonnenblende • Pare Soleil • Visera
Pára-sol • Солнцезащитный козырёк

Application	Description	Details	Ref.	Erqo No.
SK/MK	<ul style="list-style-type: none"> EN Sun visor DE Sonnenblende FR Pare-soleil ES Parasol PT Protetor de sol RU Солнцезащитный козырек 			02.23254 

Application	Description	Details	Ref.	Erqo No.
BM 381/383/385/387, 389, BM 641/642	<ul style="list-style-type: none"> EN Head lamp, left DE Hauptscheinwerfer, links FR Phare, gauche ES Faro principal, izquierdo PT Farol principal, esquerdo RU Основная фара, лев. 		641 820 0361	02.22238 
BM 381/383/385/387G89, BM 641/642	<ul style="list-style-type: none"> EN Head lamp, right DE Hauptscheinwerfer, rechts FR Phare, droit ES Faro principal, derecho PT Farol principal, direito RU Основная фара, прав. 		641 820 0461	02.22239 
BM 381/383/385/387, 389	<ul style="list-style-type: none"> EN Head lamp, left DE Hauptscheinwerfer, links FR Phare, gauche ES Faro principal, izquierdo PT Farol principal, esquerdo RU Основная фара, лев. 		381 820 1261	02.22232 
BM 381/383/385/387, 389	<ul style="list-style-type: none"> EN Head lamp, right DE Hauptscheinwerfer, rechts FR Phare, droit ES Faro principal, derecho PT Farol principal, direito RU Основная фара, прав. 		381 820 1361	02.22233 

Application	Description	Details	Ref.	Erqo No.
BM 381/383/385/387, 389	<ul style="list-style-type: none"> EN Head lamp, left DE Hauptscheinwerfer, links FR Phare, gauche ES Faro principal, izquierdo PT Farol principal, esquerdo RU Основная фара, лев. 		381 820 4361	02.22236 

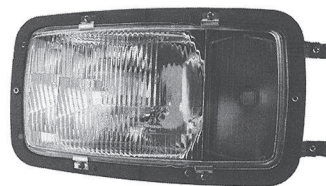

Sample

BM 381/383/385/387, 389	<ul style="list-style-type: none"> EN Head lamp, right DE Hauptscheinwerfer, rechts FR Phare, droit ES Faro principal, derecho PT Farol principal, direito RU Основная фара, прав. 		381 820 4461	02.22237 
-------------------------------	--	--	--------------	---

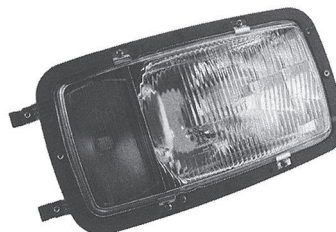









Sample

BM 381/383/385/387, 389	<ul style="list-style-type: none"> EN Lens head lamp, left DE Scheinwerferglas, links FR Verre de phare, gauche ES Cristal de fero, izquierdo PT Lente farol principal, esquerda RU Стекло фары, лев. 		002 826 1290	02.22253 
BM 641/642/649				

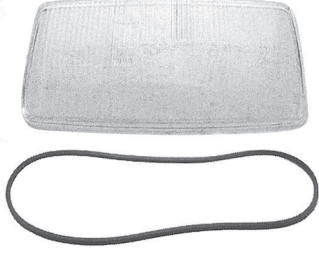

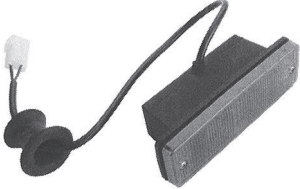
BM 381/383/385/387, 389	<ul style="list-style-type: none"> EN Lens head lamp, right DE Scheinwerferglas, rechts FR Verre de phare, droit ES Cristal de fero, derecho PT Lente farol principal, direita RU Стекло фары, прав. 		002 826 1390	02.22254 
BM 641/642/649				

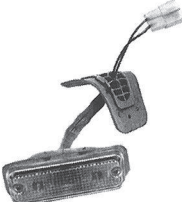

Application	Description	Details	Ref.	Erqo No.
BM 381/383/385/387, 389 BM 649	<ul style="list-style-type: none"> EN Lens, left DE Lichtscheibe, links FR Cabochon, gauche ES Tulipa, izquierdo PT Lente, esquerdo RU Рассеиватель, лев. 	R2 Bilux	002 826 0190	02.22247 
				Sample
BM 381/383/385/387, 389 BM 649	<ul style="list-style-type: none"> EN Lens, right DE Lichtscheibe, rechts FR Cabochon, droit ES Tulipa, dreita PT Lente, direito RU Рассеиватель, прав. 	R2 Bilux	002 826 0290	02.22248 
				Sample
BM 381/383/385/387, 389 BM 649	<ul style="list-style-type: none"> EN Turn signal lamp DE Blinkleuchte FR Clignotant ES Intermitente PT Lampada pisca RU Фонарь указателя поворота 		001 820 2221	02.22216 
				Sample
BM 641/642/649	<ul style="list-style-type: none"> EN Marking lamp, white DE Umrissleuchte, weiß FR Feu de gabarit, blanc ES Piloto de posición, blanco PT Lanterna lateral, branca RU Боковой габаритный фонарь, белая 		002 820 0056	02.22226 
				
BM 641/642/649	<ul style="list-style-type: none"> EN Marking lamp, white sun visor DE Umrissleuchte, weiß Sonnenblende FR Feu de gabarit, blanc pare soleil ES Piloto de posición, blanco parasol PT Lanterna lateral, branca viseira RU Боковой габаритный фонарь, белая противосолнечного козырька 		002 820 0456	02.22227 
				

THE ORIGINAL NUMBERS OF THE VEHICLE MANUFACTURER MAY BE USED FOR COMPARISON PURPOSES ONLY AND MUST NOT BE MENTIONED ON INVOICES TO VEHICLE OWNERS.

Application	Description	Details	Ref.	Erqo No.
BM 641/642/649	<ul style="list-style-type: none"> EN Marking lamp, yellow sun visor DE Umrissleuchte, gelb Sonnenblende FR Feu de gabarit, jaune pare soleil ES Piloto de posición, amarillo parasol PT Lanterna lateral, amarela viseira RU Боковой габаритный фонарь, желтая противосолнечного козырька 		002 820 0556	02.22228 
BM 641/642/649	<ul style="list-style-type: none"> EN Marking lamp, green DE Umrissleuchte, grün FR Feu de gabarit, vert ES Piloto de posición, verde PT Lanterna lateral, verde RU Боковой габаритный фонарь, зеленый 		002 820 0656	02.22229 
SK/MK/NG	<ul style="list-style-type: none"> EN High beam lamp, clear DE Fernscheinwerfer, klar FR Feux de route, clair ES Faro de carretera, claro PT Farol auxiliar, claro RU Фара дальнего света, прозрачная 	Universal, 24V 70W H7 190 mm 		02.23255 
SK/MK/NG	<ul style="list-style-type: none"> EN High beam lamp, blue DE Fernscheinwerfer, blau FR Feux de route, bleu ES Faro de carretera, azul PT Farol auxiliar, azul RU Фара дальнего света, синим цветом 	Universal, 24V 70 W H7 190 mm 		02.23255 
BM 381/383/385/387, 389 BM 641/642/649	<ul style="list-style-type: none"> EN Door contact switch DE Türkontaktschalter FR Contacteur de portière ES Interruptor, contacto de puerta PT Interruptor contato porta RU Дверной выключатель освещения 		000 821 0552	02.22241 

Application	Description	Details	Ref.	Erqo No.
BM 381/383/385/387, 389/393/395	<ul style="list-style-type: none"> EN Tail lamp, left DE Rückleuchte, links FR Feu arrière, gauche ES Piloto trasero, izquierdo PT Lanterna traseira, esquerdo RU Задний фонарь, лев. 		002 544 0203	02.21930

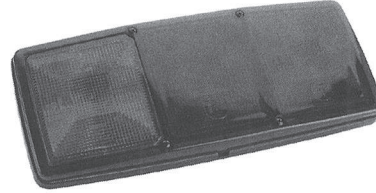

BM 381/383/385/387, 389/393/395	<ul style="list-style-type: none"> EN Tail lamp, right DE Rückleuchte, rechts FR Feu arrière, droit ES Piloto trasero, derecho PT Lanterna traseira, direito RU Задний фонарь, прав. 		001 544 7103	02.21928
---------------------------------------	--	--	--------------	----------

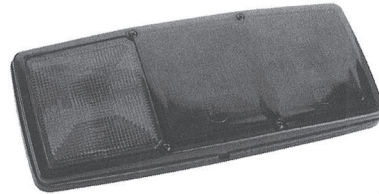

Sample

BM 381/383/385/387, 389/393/395	<ul style="list-style-type: none"> EN Lens DE Streuscheibe FR Cabochon ES Tulipa PT Lente RU Рассеиватель 		001 544 8390	02.21938
---------------------------------------	---	--	--------------	----------

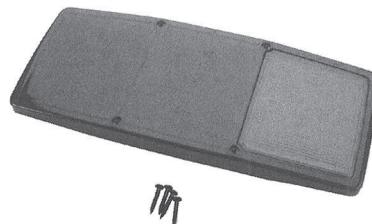





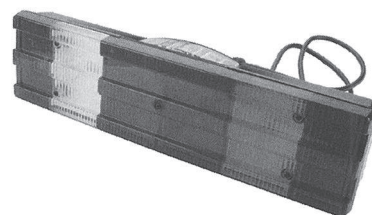

Sample

BM 625/652/653/654, 655/656/657/658, 659	<ul style="list-style-type: none"> EN Tail lamp, left DE Rückleuchte, links FR Feu arrière, gauche ES Piloto trasero, izquierdo PT Lanterna traseira, esquerdo RU Задний фонарь, лев. 		001 540 2970	02.21889
---	---	--	--------------	----------

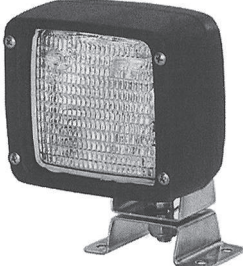

Application	Description	Details	Ref.	Erqo No.
BM 625/652/653/654, 655/656/657/658, 659	<ul style="list-style-type: none"> EN Tail lamp, right DE Rückleuchte, rechts FR Feu arrière, droit ES Piloto trasero, derecho PT Lanterna traseira, direito RU Задний фонарь, прав. 		001 540 2670	02.21888 
BM 625/650/651/652/653, 654/655/658/659	<ul style="list-style-type: none"> EN Tail lamp, left DE Rückleuchte, links FR Feu arrière, gauche ES Luz trasera, izquierdo PT Lanterna traseira, esquerdo RU Задний фонарь, лев. 		002 544 2603	02.21931 
BM 625/650/651/652/653, 654/655/658/659	<ul style="list-style-type: none"> EN Tail lamp, right DE Rückleuchte, rechts FR Feu arrière, droit ES Luz trasera, derecho PT Lanterna traseira, direito RU Задний фонарь, прав. 		002 544 4003	02.21933 
BM 625/652/653, 654/655/656, 657/658/659	<ul style="list-style-type: none"> EN Lens, left DE Lichtscheibe, links FR Cabochon, gauche ES Tulipa, izquierda PT Lente, esquerda RU Рассеиватель, лев. 		002 544 1290	02.21940 

Application	Description	Details	Ref.	Erqo No.
BM 625/652/653, 654/655/656, 657/658/659	<ul style="list-style-type: none"> EN Lens, right DE Lichtscheibe, rechts FR Cabochon, droit ES Tulipa, derecha PT Lente, direita RU Рассеиватель, прав. 		002 544 1690	02.21941 
				
NG/SK/MK	<ul style="list-style-type: none"> EN Cable DE Anschlusskabel FR Câble ES Cable conector PT Conector cachimbo RU Кабель 	M 24	380 540 2181	02.21890 
				
NG/SK/MK	<ul style="list-style-type: none"> EN Cable DE Anschlusskabel FR Câble ES Cable conector PT Conector cachimbo RU Соединительный кабель 	M 27	380 540 2281	02.21891 
				
SK/MK/NG	<ul style="list-style-type: none"> EN Auxiliary lamp DE Arbeitsscheinwerfer FR Lampe auxiliaire ES Faro auxiliar PT Lampada auxiliar RU фара рабочего освещения 	H3 / 83 x 83 mm		02.23256 
				

Application	Description	Details	Ref.	Erqo No.
SK/MK/NG	<ul style="list-style-type: none"> EN Bulb DE Glühlampe FR Ampoule ES Bombilla PT Lampada RU Лампа 	1,2 WW2 X 4,6D	002 544 1794	02.21945 
				
SK/MK/NG	<ul style="list-style-type: none"> EN Socket bulb DE Sockellampe FR Ampoule ES Bombilla con base PT Soquete lâmpada RU Цокольная лампа 	24V	307 544 0094	02.21946 
				
SK/MK/NG	<ul style="list-style-type: none"> EN Bulb DE Glühlampe FR Ampoule ES Bombilla PT Lâmpada RU Лампа 	24V 2W BA9s	072601 024801	02.22921 
				
SK/MK/NG	<ul style="list-style-type: none"> EN Bulb DE Glühlampe FR Ampoule ES Bombilla PT Lâmpada RU Лампа 	24V 3W BA7s		02.23303 
				
SK/MK/NG	<ul style="list-style-type: none"> EN Bulb DE Glühlampe FR Ampoule ES Bombilla PT Lâmpada RU Лампа 	24V 4W BA9s HD		02.23304 
				
SK/MK/NG	<ul style="list-style-type: none"> EN Bulb DE Glühlampe FR Ampoule ES Bombilla PT Lâmpada RU Лампа 	24V 4W BA9s	072601 024900	02.22923 
				









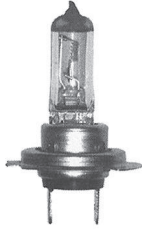

THE ORIGINAL NUMBERS OF THE VEHICLE MANUFACTURER MAY BE USED FOR COMPARISON PURPOSES ONLY AND MUST NOT BE MENTIONED ON INVOICES TO VEHICLE OWNERS.

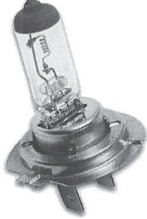
Application	Description	Details	Ref.	Erqo No.
SK/MK/NG	<ul style="list-style-type: none"> EN Bulb DE Glühlampe FR Ampoule ES Bombilla PT Lâmpada RU Лампа 	24V 5W W2,1X9,5d	072601 024250	02.22916 
				
SK/MK/NG	<ul style="list-style-type: none"> EN Bulb DE Glühlampe FR Ampoule ES Bombilla PT Lâmpada RU Лампа 	24V 5W BA15s	072601 024701	02.22918 
				
SK/MK/NG	<ul style="list-style-type: none"> EN Bulb DE Glühlampe FR Ampoule ES Bombilla PT Lâmpada RU Лампа 	24V 5W BA15s HD		02.23306 
				
SK/MK/NG	<ul style="list-style-type: none"> EN Bulb DE Glühlampe FR Ampoule ES Bombilla PT Lâmpada RU Лампа 	24V 10W Ba 15s	072601 024702	02.22919 
				
SK/MK/NG	<ul style="list-style-type: none"> EN Bulb DE Glühlampe FR Ampoule ES Bombilla PT Lampada RU Лампа 	24V 10W BA15s HD	072601 024704	02.22920 
				
SK/MK/NG	<ul style="list-style-type: none"> EN Bulb DE Glühlampe FR Ampoule ES Bombilla PT Lâmpada RU Лампа 	24V 21W Ba 15s	001 544 5994	02.21944 
				

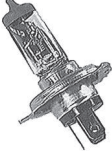

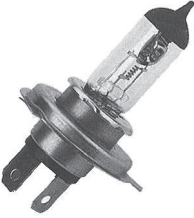





THE ORIGINAL NUMBERS OF THE VEHICLE MANUFACTURER MAY BE USED FOR COMPARISON PURPOSES ONLY AND MUST NOT BE MENTIONED ON INVOICES TO VEHICLE OWNERS.

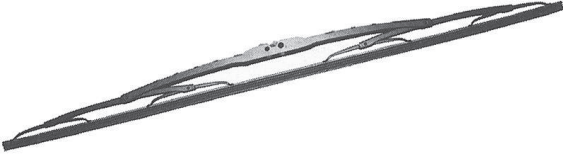



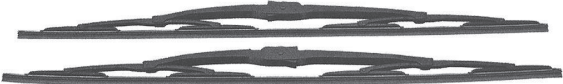



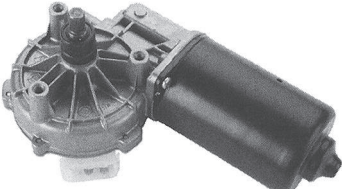

Application	Description	Details	Ref.	Erqo No.
SK/MK/NG	<ul style="list-style-type: none"> EN Bulb DE Glühlampe FR Ampoule ES Bombilla PT Lampada RU Лампа 	24V 21W Ba 15s HD	072601 024192	02.22915 
				
SK/MK/NG	<ul style="list-style-type: none"> EN Bulb DE Glühlampe FR Ampoule ES Bombilla PT Lâmpada RU Лампа 	24V 21/5W BAY 15d		02.23308 
				
SK/MK/NG	<ul style="list-style-type: none"> EN Bulb DE Glühlampe FR Ampoule ES Bombilla PT Lâmpada RU Лампа 	24V 21/5W BAY 15d HD		02.23309 
				
SK/MK/NG	<ul style="list-style-type: none"> EN Bulb DE Glühlampe FR Ampoule ES Bombilla PT Lâmpada RU Лампа 	Bilux 24V 55/50W	072601 024100	02.22913 
				
SK/MK/NG	<ul style="list-style-type: none"> EN Bulb DE Glühlampe FR Ampoule ES Bombilla PT Lampada RU Лампа 	24V 70W H3 Pk 22s	400809 000006	02.22949 
				
SK/MK/NG	<ul style="list-style-type: none"> EN Bulb DE Glühlampe FR Ampoule ES Bombilla PT Lampada RU Лампа 	24V 70WH1 P14,5s	072601 024270	02.22917 
				

THE ORIGINAL NUMBERS OF THE VEHICLE MANUFACTURER MAY BE USED FOR COMPARISON PURPOSES ONLY AND MUST NOT BE MENTIONED ON INVOICES TO VEHICLE OWNERS.



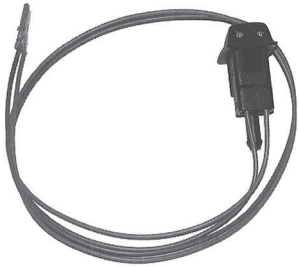

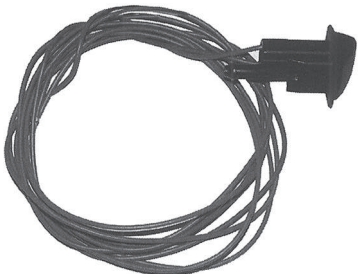



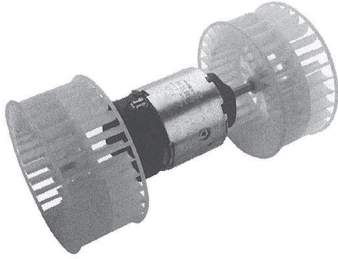

Application	Description	Details	Ref.	Erqo No.
SK/MK/NG	<ul style="list-style-type: none"> EN Bulb DE Glühlampe FR Ampoule ES Bombilla PT Lâmpada RU Лампа 	24V 70W PX26d H7		02.23310
				
SK/MK/NG	<ul style="list-style-type: none"> EN Bulb DE Glühlampe FR Ampoule ES Bombilla PT Lampada RU Лампа 	H7-24V / 70W HD	000000 004221	02.22802
				
SK/MK/NG	<ul style="list-style-type: none"> EN Bulb DE Glühlampe FR Ampoule ES Bombilla PT Lampada RU Лампа 	75/70W H4	072601 024802	02.22922
				
SK/MK/NG	<ul style="list-style-type: none"> EN Bulb DE Glühlampe FR Ampoule ES Bombilla PT Lâmpada RU Лампа 	24V 75/70W P43t H4 HD		02.15944
				
SK/MK/NG	<ul style="list-style-type: none"> EN Lamp socket DE Lampenfassung FR Douille de lampe ES Portalámparas PT Soquete lâmpada RU Патрон лампы 		000 545 2319	02.22009
				

THE ORIGINAL NUMBERS OF THE VEHICLE MANUFACTURER MAY BE USED FOR COMPARISON PURPOSES ONLY AND MUST NOT BE MENTIONED ON INVOICES TO VEHICLE OWNERS.

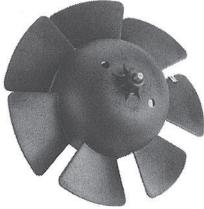

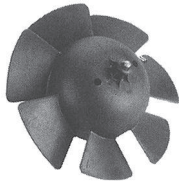

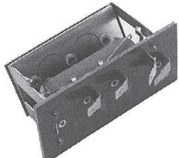





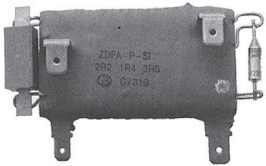

Application	Description	Details	Ref.	Erqo No.
BM 381/383/385/387, 393/395	<ul style="list-style-type: none"> EN Wiper blade DE Wischerblatt FR Balai d'essuie-glace ES Escobilla limpiaparabrisas PT Palheta limpador RU Щетка стеклоочистителя 	700 mm	001 820 1245	02.22223 
				
BM 389/641/642	<ul style="list-style-type: none"> EN Wiper blade DE Wischerblatt FR Balai d'essuie-glace ES Escobilla limpiaparabrisas PT Palheta limpador RU Щетка стеклоочистителя 	650 mm	001 820 1145	02.22222 
				
BM 389/641/642	<ul style="list-style-type: none"> EN Wiper blade set DE Wischerblattsatz FR Balai d'essuie-glace ES Escobilla limpiaparabrisas PT Jogo palheta limpador RU Щетка стеклоочистителя 	650 mm	001 820 4745	02.22224 
				
BM 381/383/385/387	<ul style="list-style-type: none"> EN Wiper arm DE Wischerarm FR Bras d'essui-glace ES Brazo del limpiaparabrisas PT Braço limpador RU Рычаг стеклоочистителя 	495 mm	381 824 0228	02.22246 
				
BM 381/383/385/387, 389/393/395	<ul style="list-style-type: none"> EN Wiper motor DE Wischermotor FR Moteur d'essuie-glace ES Motor de limpiaparabrisas PT Motor limpador pára-brisa RU Электродвигатель 	repl. Bosch: 0 390 242 404	004 820 6742	02.22220 
				

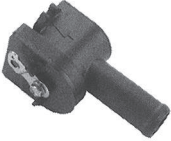
Application	Description	Details	Ref.	Erqo No.
BM 381/383/385/387, 389/393/395	<ul style="list-style-type: none"> EN Washer pump DE Wischwasserpumpe FR Pompe de lave glace ES Bomba de agua limpiaparabrisas PT Bomba limpador pára-brisa, elétrica RU Насос стеклоомывателя 		000 860 3226	02.22268 
BM 381/383/397	<ul style="list-style-type: none"> EN Washer pump DE Wischwasserpumpe FR Pompe de lave glace ES Bomba de agua limpiaparabrisas PT Bomba limpador pára-brisa, elétrica RU Насос стеклоомывателя 		000 869 3121	02.22271 
BM 381/383/385/387, 389/393/395	<ul style="list-style-type: none"> EN Wiper nozzle DE Wischerdüse FR Gicleur d'essuie-glace ES Tobera del limpiaparabrisas PT Injetor lavador parabisa RU Форсунка стеклоочистителя 		000 869 3347	02.22272 
BM 641/642/649	<ul style="list-style-type: none"> EN Wiper nozzle, left, heated DE Wischerdüse, links, beheizt FR Gicleur d'essuie-glace, gauche, chauffé ES Tobera del limpiaparabrisas, izquierdo, calefactado PT Injetor lavador pára-brisa, esquerdo, aquecimento RU Форсунка стеклоочистителя, лев., обогреваемое 		000 860 1047	02.22270 
BM 641/642/649	<ul style="list-style-type: none"> EN Wiper nozzle, right, heated DE Wischerdüse, rechts, beheizt FR Gicleur d'essuie-glace, droit, chauffé ES Tobera del limpiaparabrisas, derecho, calefactado PT Injetor lavador pára-brisa, direito, aquecimento RU Форсунка стеклоочистителя, прав., обогреваемое 		000 860 0647	02.22269 

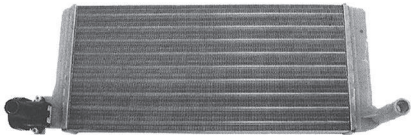
THE ORIGINAL NUMBERS OF THE VEHICLE MANUFACTURER MAY BE USED FOR COMPARISON PURPOSES ONLY AND MUST NOT BE MENTIONED ON INVOICES TO VEHICLE OWNERS.

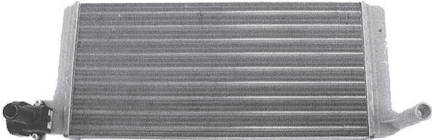
Application	Description	Details	Ref.	Erqo No.
BM 641/642/649	<ul style="list-style-type: none"> EN Fan motor DE Gebläsemotor FR Ventilateur de chauffage ES Motor del soplador PT Motor ventilador RU Электродвигатель вентилятора 		001 830 0308	02.22256 
BM 641/642/649	<ul style="list-style-type: none"> EN Fan motor DE Gebläsemotor FR Ventilateur de chauffage ES Motor del ventilador PT Motor ventilador RU Электродвигатель вентилятора 		000 830 8608	02.22255 
BM 381/383/385/387	<ul style="list-style-type: none"> EN Fan motor DE Gebläsemotor FR Ventilateur de chauffage ES Motor del ventilador PT Motor ventilador RU Электродвигатель вентилятора 		000 820 9742	02.22218 
BM 381/383	<ul style="list-style-type: none"> EN Fan motor DE Gebläsemotor FR Ventilateur de chauffage ES Motor del ventilador PT Motor ventilador RU Электродвигатель вентилятора 		000 820 6242	02.22217 
BM 641/642/649	<ul style="list-style-type: none"> EN Resistor unit DE Widerstandskörper FR Résistance ES Resistor PT Resistência RU Резистор 		000 821 9960	02.22242 

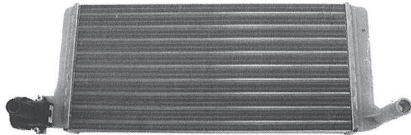
THE ORIGINAL NUMBERS OF THE VEHICLE MANUFACTURER MAY BE USED FOR COMPARISON PURPOSES ONLY AND MUST NOT BE MENTIONED ON INVOICES TO VEHICLE OWNERS.

Application	Description	Details	Ref.	Erqo No.
BM 641/642/649	<ul style="list-style-type: none"> EN Resistor DE Widerstand FR Resistance ES Resistencia PT Resistência RU Резистор 		001 821 7860	02.22244 
BM 381/383/385/387	<ul style="list-style-type: none"> EN Heating control valve DE Heizungsventil FR Soupape chauffage ES Válvula de la calefacción PT Válvula controle aquecimento RU Клапан подвода жидкости 		000 830 1384	02.22260 
BM 381/383/385/387/389	<ul style="list-style-type: none"> EN Heating control valve DE Heizungsventil FR Soupape chauffage ES Válvula de la calefacción PT Válvula controle aquecimento RU Клапан подвода жидкости 		000 830 3584	02.22261 
BM 381/383/385/387	<ul style="list-style-type: none"> EN Heat exchanger DE Wärmetauscher FR Radiateur de chauffage ES Intercambiadorde calor PT Trocador calor RU Теплообменник 		002 835 0801	02.22263 
BM 389	<ul style="list-style-type: none"> EN Heat exchanger DE Wärmetauscher FR Radiateur de chauffage ES Intercambiador de calor PT Trocador calor RU Теплообменник 		002 835 2701	02.22264 
				Sample
BM 649	<ul style="list-style-type: none"> EN Heat exchanger DE Wärmetauscher FR Radiateur de chauffage ES Intercambiador de calor PT Trocador calor RU Теплообменник 		002 835 6801	02.22265 
				Sample

THE ORIGINAL NUMBERS OF THE VEHICLE MANUFACTURER MAY BE USED FOR COMPARISON PURPOSES ONLY AND MUST NOT BE MENTIONED ON INVOICES TO VEHICLE OWNERS.

Application	Description	Details	Ref.	Erqo No.
BM 649	<ul style="list-style-type: none"> EN Cabin air filter DE Kabinenluftfilter FR Filtre à air cabine ES Filtro de aire de la cabina PT Filtro de ar, cabina RU Воздушный фильтр кабины 		000 835 6947	02.22265 
BM 381/383/385/387	<ul style="list-style-type: none"> EN Hose DE Schlauch FR Durite ES Tubo flexible PT Mangueira RU Шланг 		381 832 1823	02.22262 

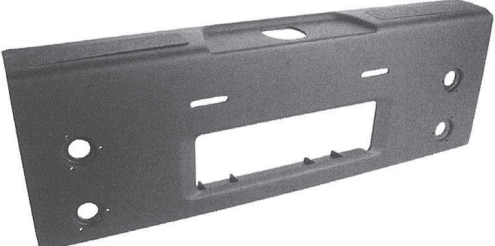



Application	Description	Details	Ref.	Erqo No.
BM 641/642/649	<ul style="list-style-type: none"> EN Bumper, left DE Stoßstangenteil, links FR Pare-chocs, gauche ES Esquina del parachoques, izquierda PT Pára-choque, esquerdo RU Угол бампера, лев. 		641 880 9970	02.22279 
BM 641/642/649	<ul style="list-style-type: none"> EN Bumper, right DE Stoßstangenteil, rechts FR Pare-chocs, droit ES Esquina del parachoques, derecha PT Pára-choque, direito RU Угол бампера, прав. 		641 880 0473	02.22280 
BM 641/642/649	<ul style="list-style-type: none"> EN Bumper, middle part DE Stoßstange, Mitte FR Pare-chocs, central ES Parachoques, central PT Pára-choque, central RU Деталь бампера, Центр 		641 880 0270	02.22275 
BM 641/642/649	<ul style="list-style-type: none"> EN Bumper, middle part DE Stoßstange, Mitte FR Pare-chocs, central ES Parachoques, central PT Pára-choque, central RU Бампер, Центр 		641 880 3770	02.22276 

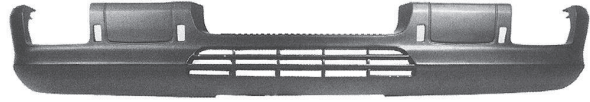



BumperStoßstange • Pare-chocs • Parachoques
Pára-choques • Бампер

Application	Description	Details	Ref.	Erqo No.
BM 649	<ul style="list-style-type: none"> EN Spoiler, below DE Spoiler, unten FR Spoiler, en bas ES Spoiler delantero, inferior PT Spoiler, inferior RU Спойлер, нижн. 		649 880 0736	02.22274 



Application	Description	Details	Ref.	Erqo No.
BM 641/642	EN Mudguard part, left		641 881 6901	02.23257 
	DE Kotflügel, links			
	FR Aile avant, gauche			
	ES Guardabarros, izquierdo			
	PT Pára-lama, esquerdo			
	RU Крыло, лев.			
BM 641/642	EN Mudguard part, right		641 881 7001	02.22282 
	DE Kotflügel, rechts			
	FR Aile avant, droite			
	ES Guardabarros, derecho			
	PT Pára-lama, direito			
	RU Крыло, прав.			

Application	Description	Details	Ref.	Erqo No.
BPW	<ul style="list-style-type: none"> EN Spring DE Feder FR Ressort ES Muelle PT Mola RU Пружина 	L = 180 mm	03.397.34.10.0	02.23258 
BPW	<ul style="list-style-type: none"> EN Spring DE Feder FR Ressort ES Muelle PT Mola RU Пружина 	L = 148 mm	05.397.26.03.0	02.23259 
BPW	<ul style="list-style-type: none"> EN Spring DE Feder FR Ressort ES Muelle PT Mola RU Пружина 	L = 265 mm	05.397.46.03.0	02.23260 
BPW	<ul style="list-style-type: none"> EN Spring DE Feder FR Ressort ES Muelle PT Mola RU Пружина 	L = 260 mm	05.397.46.06.0	02.23260 
BPW	<ul style="list-style-type: none"> EN Spring DE Feder FR Ressort ES Muelle PT Mola RU Пружина 	L = 167 mm	05.397.46.12.0	02.23260 

Application	Description	Details	Ref.	Erqo No.
BPW	<ul style="list-style-type: none"> EN Return spring DE Rückholfeder FR Ressort de mâchoire ES Muelle de retorno PT Mola retorno RU Возвратная пружина 	L = 156 mm	05.397.45.05.0	02.23261 
BPW	<ul style="list-style-type: none"> EN Return spring DE Rückholfeder FR Ressort de mâchoire ES Muelle de retorno PT Mola retorno RU Возвратная пружина 	L = 163 mm	05.397.35.03.0	02.23261 
BPW	<ul style="list-style-type: none"> EN Return spring DE Rückholfeder FR Ressort de mâchoire ES Muelle de retorno PT Mola retorno RU Возвратная пружина 	L = 235 mm	05.397.26.02.0	02.23262 
BPW	<ul style="list-style-type: none"> EN Return spring DE Rückholfeder FR Ressort de mâchoire ES Muelle de retorno PT Mola retorno RU Возвратная пружина 	L = 100 mm	03.397.34.01.0	02.23263 
BPW	<ul style="list-style-type: none"> EN Return spring DE Rückholfeder FR Ressort de mâchoire ES Muelle de retorno PT Mola retorno RU Возвратная пружина 	L = 112 mm	03.397.34.02.0	02.23264 

Application	Description	Details	Ref.	Erqo No.
SAF	<ul style="list-style-type: none"> EN Brake shoe spring DE Bremsbackenfeder FR Ressort de mâchoire de frein ES Muelle de zapata del freno PT Mola sapata freio RU Стяжная пружина 	L = 228 mm	1.447.0038.00	02.23265

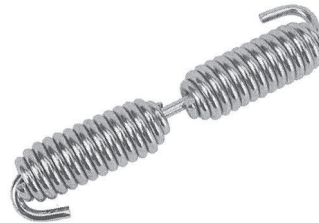

SAF	<ul style="list-style-type: none"> EN Brake shoe spring DE Bremsbackenfeder FR Ressort de mâchoire de frein ES Muelle de zapata del freno PT Mola sapata freio RU Стяжная пружина 	L = 190 mm	1.447.0021.01	02.23266
-----	---	------------	---------------	----------



ROR	<ul style="list-style-type: none"> EN Brake shoe spring DE Bremsbackenfeder FR Ressort de mâchoire de frein ES Muelle de zapata del freno PT Mola sapata freio RU Стяжная пружина 	L = 203 mm	210 23389	02.23267
-----	---	------------	-----------	----------

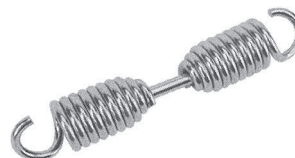

ENDURANCE...
RELIABILITY...
QUALITY...
OEM SATISFACTION

ERQO[®]
spare part products

ERKU OTOMOTIV SAN. VE TIC. LTD. STI.

Ikitelli Org. San. Bölge Dolapdere San.

Sit. 19. Ada No:18 Basaksehir

ISTANBUL - TURKEY

Tel : +90 212 407 02 68

Fax : +90 212 407 02 87

E-mail : info@erqo.com.tr

Web : www.erqo.com.tr